

West Bengal State Electricity Distribution Company Limited  
(A Government of West Bengal Enterprise)  
(IT & Communication Cell)

Vidyut Bhavan, 3rd Floor, C&D Block, Bidhan Nagar, Block-DJ, Sec-II, Kolkata-700091

Website: [www.wbsedcl.in](http://www.wbsedcl.in), e-mail: [itcell@wbsedcl.in](mailto:itcell@wbsedcl.in), [ceit@wbsedcl.in](mailto:ceit@wbsedcl.in)

Phone No:

CIN: U40109WB2007SGC113473

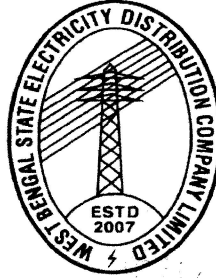

Request for Proposal for DC/DRC infrastructure upgradation under  
IT/IT-OT implementation at  
**WEST BENGAL STATE ELECTRICITY DISTRIBUTION COMPANY LIMITED**  
under Loss Reduction Part of

**"Revamped Reforms-Linked Results-Based Distribution Sector Scheme" (RDSS)**

**Tender No. WBSEDCL/IT&C/114.00(RDSS)/2527 Dated 28.02.2024**

A handwritten signature in black ink, appearing to be "S. K. Das" followed by the date "28/02/2024".

Chief Engineer  
IT&C Cell, WBSEDCL

**Open E-Tender No. WBSEDCL/IT&C/114.00(RDSS)/2527 Dated 28.02.2024**

**(Single Stage Two-Envelope Bidding Process with e-Procurement)**

**Request for Proposal for DC/DRC infrastructure upgradation under  
IT/IT-OT implementation at**

**WEST BENGAL STATE ELECTRICITY DISTRIBUTION COMPANY LIMITED under  
Loss Reduction Part of**

**"Revamped Reforms-Linked Results-Based Distribution Sector Scheme"**

**(RDSS)**

### **Key Dates**

<b>Sl No.</b>	<b>Particulars</b>	<b>Description</b>
1	Date of release of RFP/ NIT	06.03.2024 14:00 Hrs
2	Last Date and Time for the submission of Pre-Bid Queries	20.03.2024 14:00 Hrs
3	Date and Time of Pre-bid Meeting	27.03.2024 12:00 Hrs
4	Bid submission Start date	08.04.2024 15:00 Hrs
5	Bid submission last date	14.05.2024 13:00 Hrs
6	Date & Time of Opening of Technical Proposal	14.05.2024 14:00 Hrs
7	Earnest Money Deposit (EMD)@2%	91.54 Lakhs (Ex. GST)
8	Cost of Bid Document	NIL
9	Estimated Project Cost for DC/DRC infrastructure upgradation under IT/IT-OT implementation at WEST BENGAL STATE ELECTRICITY DISTRIBUTION COMPANY LIMITED under Loss Reduction Part of "Revamped Reforms-Linked Results-Based Distribution Sector Scheme" (RDSS)	45.77 Crore INR (Ex. GST)

---

Tel (O):-033- 2319 7445, 2319 7442

Website: [www.wbsedcl.in](http://www.wbsedcl.in), Email: [ceit@wbsedcl.in](mailto:ceit@wbsedcl.in) / [itcell@wbsedcl.in](mailto:itcell@wbsedcl.in)

---

## SUMMARY

### **PART I – BIDDING PROCEDURES AND REQUIREMENTS**

#### **Section 1: Request for Bids Notice /Notice Inviting Tender**

This Section includes Request for Bids (RFB)/ Notice Inviting Tender (NIT)

#### **Section 2: Eligibility and Qualification Requirements**

This Section contains information regarding specific eligibility and qualification requirements applicable for prospective bidders to be considered for further evaluation of their bids.

#### **Section 3: Instructions to Bidders (ITB) and Bid Data Sheet (BDS)**

This Section consists of two parts: “Instructions to Bidders” and “Bid Data Sheet (BDS)”. “Bid Data Sheet” contains information specific to procurement that corresponds to and/or supplements and/or modifies “Instructions to Bidders”. This Section provides information to help prospective bidders prepare their bids. Information is also provided on the bidding process - **Single Stage Two-Envelope Bidding Process with e-Procurement**, submission, opening, and evaluation of bids, selection of successful bidder and on the award of contract.

#### **Section 4: Bidding Forms - Technical Part of the Bid**

This Section includes the forms for Technical Part of the bid, that are to be completed by the Bidders and submitted in accordance with the requirements of Section 3.

#### **Section 5: Bidding Forms - Financial Part of the Bid**

This Section includes the forms for Financial Part of the bid including Price Schedules, that are to be completed the Bidders and submitted in accordance with the requirements of Section 3.

### **PART 2 – EMPLOYER’S REQUIREMENTS**

#### **Section 6: Employer’s Requirements**

This Section specifies the Scope of Work, Specification, the Drawings, and supplementary information that describe the Plant and Installation Services to be procured.

---

## **PART 3 – CONDITIONS OF CONTRACT AND CONTRACT FORMS**

### **Section 7: Conditions of Contract**

This Section consists of two parts: General Conditions of Contract (GCC) and Special Conditions of Contract (SCC). GCC includes general clauses to be applicable to the Contract and the contents of SCC modify or supplement GCC.

### **Section 8 - Contract Forms**

This Section contains the Letter of Acceptance/ Notification of Award, forms which, once completed, will form part of the Contract. The forms for Performance Security and Advance Payment Security, when required, shall only be completed by the successful Bidder after contract award.

---

## Table of Contents

Section - 1 : Request for Bids Notice.....	8
Section – 2 : Eligibility and Qualification Requirements .....	13
Section - 3 : Instructions to Bidders and Bid Data Sheet.....	22
A.    Instructions to Bidders .....	22
1.    Scope of Bid and Definitions .....	22
2.    Fraud and Corruption .....	25
3.    Eligibility, Qualification Requirements .....	25
4.    Conflict of Interest .....	25
B.    Contents of Bidding Documents.....	26
5.    Sections of Bidding Document .....	27
6.    Bidding Process Management, Clarification of the Bidding Document, Site Visit and Pre-Bid Meeting.....	27
7.    Addenda/ Corrigendum/Amendment of Bidding Document .....	29
C.    Preparation of Bids.....	29
8.    Cost of Bidding.....	29
9.    Language of Bid.....	30
10.   Documents comprising Bid.....	30
11.   Process of Bid Submission.....	32
12.   Alternative Bids .....	32
13.   Bid prices and Discounts .....	32
14.   Currencies of Bid and Payment .....	37
15.   Documents Establishing the Conformity of the Plant and Installation Services/ Works	37

---

16. Documents Establishing the Eligibility and Qualifications of the Bidder and Eligibility of Plant and Installation Services.....	39
17. Period of Validity of Bids .....	39
18. Bid Security/ Bid Securing Declaration.....	40
19. Format and Signing of Bid.....	41
D. Submission of Bids.....	42
20. Submission of Bids .....	42
21. Deadline for Submission of Bids .....	43
22. Late Bids .....	43
23. Withdrawal, Substitution, and Modification of Bids.....	43
E. Public Opening of Technical Parts of Bids.....	44
24. Public Opening of Technical Parts of Bids.....	44
F. Evaluation of Bids – General Provisions.....	45
25. Confidentiality .....	45
26. Clarification of Bids.....	45
27. Deviations, Reservations, and Omissions.....	45
28. Nonmaterial Nonconformities, Errors and Omissions.....	46
G. Evaluation of Technical Parts of Bids.....	46
29. Evaluation of Technical Parts .....	46
30. Determination of Responsiveness.....	48
H. Public Opening of Financial Parts of Bids.....	49
31. Public Opening of Financial Parts .....	49
I. Evaluation of Financial Parts of Bids.....	50
32. Evaluation of Financial Parts .....	50
33. Correction of Arithmetical Errors .....	51
34. Comparison of Financial Parts.....	51

35.	Preference .....	51
36.	Abnormally Low Bids.....	51
37.	Unbalanced or Front Loaded Bids .....	52
38.	Most Advantageous Bid.....	52
39.	Employer’s Right to Accept Any Bid, and to Reject Any or All Bids .....	53
	J. Award of Contract.....	53
40.	Award Criteria .....	53
41.	Employer’s Right to make minor adjustments at the time of Award.....	54
42.	Notification of Award.....	54
43.	Signing of Contract .....	54
	H. Performance Security & Funds.....	55
44.	Performance Security.....	55
45.	Source of Funds .....	55
46.	Dedicated bank account of Contractor/Bidder.....	55
	I. Bid Data Sheet (BDS).....	57
	Bidder Help Manual for E-Bidding.....	64
	Section - 4 : Bidding Forms - Technical Part of the Bid.....	66
	Form 1 .....	67
	Letter of Bid – Technical Part.....	67
	Form 2.....	72
	Format for Bidder Information Sheet.....	72
	Form 3A .....	74
	Format of Bid Securing Declaration (if applicable).....	74
	Form 3B .....	76
	Format of Bank Guarantee for Bid Security .....	76
	Form 4.....	78
	Format of Power of Attorney of designated Bid Signatory by sole bidder/ lead joint venture member .....	78
	Form 5.....	80
	Format of Declaration of conformance of the Bidder and the Facilities offered, to the specified eligibility requirement .....	80

Form 6.....	81
Format for Affidavit of Self certification regarding Local Content in line with PPP-MII order and #MoP Order/DoT order .....	81
Form 7.....	84
Format Of Power of Attorney by Each Member/ Partner of The Joint Venture in favour of Lead Member/ Partner .....	84
Form 8.....	87
Format of Joint Deed of Undertaking by the Joint Venture Partners/ Members .....	87
Joint Venture Agreement .....	91
Form 9.....	92
Format for Details/ Data and Documentary Evidence in support of meeting the Qualification Requirement.....	92
Form 10.....	98
Format of Bought-out & Sub-contracted Items .....	98
Form 11.....	100
Format of Undertaking on Compliance of Terms & Conditions of the Bidding Documents including Scope of Work and other related requirements .....	100
Form 12.....	103
Format of Alternative, Deviations and Exceptions to the Provisions of RFB Document .....	103
Form 13.....	105
Format of Work Completion Schedule .....	105
Form 14.....	110
Format of Guarantee Declaration.....	110
Form 15.....	112
Format of Information regarding Ex-employees .....	112
Form 16.....	114
Format for Price Adjustment Data.....	114
Form 17.....	116
Format of Option for Initial Advance (either Interest Bearing Initial Advance or No Initial Advance) and Information for E-payment, PF details and declaration regarding Micro/Small & Medium Enterprises.....	116
Form 18.....	120
FORMAT OF Declaration for tax exemptions, reductions, allowances or benefits)....	120
Form 19.....	122
Format of Bank Guarantee verification Check list .....	122
Form 20.....	127
Format of Additional Information .....	127
Form 21.....	131



---

Format of Integrity Pact .....	131
Form 22 .....	139
Format of the Bank Guarantee For Additional Performance Security Deposit.....	139
Section - 5 : Bidding Forms - Financial Part of the Bid.....	141



## **PART 1**

# **BIDDING PROCEDURES AND REQUIREMENTS**

## Section - 1: Request for Bids Notice/Notice Inviting Tender

### West Bengal State Electricity Distribution Company Limited

#### OPEN COMPETITIVE PROCUREMENT

##### **Request for Bids (RFB)/ Notice Inviting Tender (NIT)** **(Single Stage Two-Envelope Bidding Process with e-Procurement)**

**Contract title: Infrastructure upgradation of DC/DRC under IT/IT-OT implementation Under ‘Revamped Reforms-Linked Results-Based Distribution Sector Scheme’ (RDSS).**

**NIT/RFB No: WBSEDCL/IT&C/114.00(RDSS)/2527 Dated 28.02.2024**

**Issued on: 28.02.2024**

The Project shall be executed (in Turnkey mode), WBSEDCL invites sealed bids in two part (Part I: Techno-Commercial, Part II: Price) under the Domestic Competitive bidding: -

1. WBSEDCL (hereinafter also referred to as the **Employer** or the **Utility**) invites online Bids for **Infrastructure upgradation of DC/DRC under IT/IT-OT implementation** under Revamped Reforms based and Results linked Distribution Sector Scheme. As described in different clauses and sub-clauses under different specific sections.
2. Bidding will be conducted through open competitive e-procurement.
3. The RFB document (hereinafter also referred to as bidding document) is available online free of cost, for downloading on [www.wbtenders.gov.in](http://www.wbtenders.gov.in) from 06.03.2024 14:00 Hrs to 14.05.2024 13:00 Hrs. The bidder would be responsible for ensuring that any addenda/corrigendum/amendment etc. available on the website/portal is also downloaded and incorporated.
4. The bidding shall be conducted **under Single Stage Two-Envelope Bidding process with e-Procurement.**
5. Under the Single Stage Two-Envelope Bidding process, the Bidder shall not quote, disclose, or submit its price in the Technical Part (First Envelope) of its bid or in any other manner, whatsoever, except as part of the Financial Part (Second Envelope) of its bid. In case of any non-compliance in this regard, the bids shall be out-rightly /summarily rejected.
6. An incomplete and/or ambiguous and/or conditional bid and/or bid submitted late is liable to be ignored/ summarily rejected.
7. Bid must be submitted online through the e-Procurement/e-Tendering process. Any bid or modifications to bid received outside the e-Procurement system will not be considered, unless otherwise specified. The Utility shall not be held liable for any delay due to e-

Procurement/e-Tendering system failure beyond its control. Even though the system will attempt to notify the bidders of any bid updates, the Utility shall not be liable for any information not received by the bidder. It is the bidders' responsibility to verify the website for the latest information related to this RFB.

8. Salient details pertaining to this RFB Notice including submission and opening of bid, bid security, cost of documents/tender fee, if any, for downloading the bidding document, address for communication, etc, are given in the TABLE below.
9. All the notarized documents shall be furnished in the stamp paper of cost Rs.100/-.
10. If the Utility office happens to be closed on the specified date of opening of the bids, the bids will be opened on the next working day at the same time and venue or as may be notified by the Utility.
11. Other details can be seen in the RFB document.

## TABLE

<b>RFB Notice/NIT No.</b>	<b>WBSEDCL/IT&amp;C/114.00(RDSS)/2527 Dated 28.02.2024</b>
<b>Contract Title for the Procurement</b>	<b>Infrastructure upgradation of DC/DRC under IT/IT-OT implementation at WEST BENGAL STATE ELECTRICITY DISTRIBUTION COMPANY LIMITED under Loss Reduction Part of "Revamped Reforms-Linked Results-Based Distribution Sector Scheme" (RDSS).</b>
<b>Brief description of Scope of Works</b>	<p>The objective is to provide logically unified and shared infrastructure flexible enough to rapidly respond to infrastructure requirements and accommodate future technology enhancements, distributed applications, database applications running on bare metal, and virtualized applications running in hypervisor environments, that are available on demand all impose different demands on infrastructure.</p> <p><b>Network Speed Enhancement:</b> WBSEDCL Internal Network speed is to be enhanced to at least 10G.</p> <p><b>Software Defined Network:</b> Movement towards a fault tolerant SD Network.</p> <p><b>Virtualization:</b> The Compute and Storage must be used to build a Virtualized environment such that all current and future applications will be virtual cloud like infrastructure within WBSEDCL premises.</p> <p><b>Roadmap to SAP 4 HANA:</b> WBSEDCL is moving towards SAP4 HANA in future. The upgraded compute system must be compliant to SAP 4 HANA</p> <p><b>Support for five years after Go Live:</b> Go Live will be the start day of support. IA will arrange to supply all materials, complete the installation, integration, migration, and the subsequent acceptance test criteria to obtain the Go Liv. Support will consist of three years of warranty and an additional two years of AMC/ATS comprising, all spares, services, and licenses.</p> <p><b>Buyback Policy Compliance:</b> Ensure adherence to the outlined guidelines and policies regarding equipment buyback.</p>
<b>Mode of Procurement/Bidding</b>	Singe Stage Two-Envelope Bidding Process with e-Procurement/e-Tendering
<b>Date of Release of RFB Notice/NIT</b>	<b>06.03.2024 14:00 Hrs.</b>
<b>Date &amp; Time of Pre-Bid Meeting</b>	<b>27.03.2024 12:00 Hrs.</b>
<b>Last date of Bid Submission</b>	<b>14.05.2024 13:00 Hrs.</b>
<b>Date of Opening of Technical Part (First Envelope) of the bid</b>	<b>14.05.2024 14:00 Hrs.</b>
<b>Date of submission of BG (To be physically handed over, scanned copy of the same will be uploaded electronically through e-tendering.</b>	<b>14.05.2024 13:00 Hrs.</b>

<b>Opening of Financial Part (Second Envelope) of the Bid</b>	To be notified later. Financial Part of bids from only those bidders shall be opened who, upon evaluation of Technical Part of the bids, are found eligible and qualified, and whose bids are found responsive to Bidding documents.
---	--

<b>Location of Submission/Opening of Bids, as applicable</b>	Chief Engineer , IT WBSEDCL Vidyut Bhawan, 3 <sup>rd</sup> Floor, D-Block, Block-DJ, Sector-II, Bidhannagar, Kolkata-700091 Tel (O) : 033-23197445 Website: <a href="http://www.wbstedcl.in">www.wbstedcl.in</a> , Email: <a href="mailto:ceit@wbstedcl.in">ceit@wbstedcl.in</a>
<b>Type of Procurement</b>	Plant (Design, Supply, Installation and Support)
<b>EMD/ Bid Security</b>	All bids must be accompanied by a bid security- 2% of the estimated price i.e. 91.54 Lakhs lakhs.
<b>Performance Security</b>	The Performance Security amount is 10% of Contract Price excluding GST.
<b>Bid Validity period</b>	The bid validity period will be 180 days from date of Opening of Technical Part of the Bid.
<b>Time for Completion</b>	The Time for Completion of the works is 12 (Twelve) Months from the Effective Date of the Contract.
<b>Address for Correspondence</b>	Chief Engineer, IT WBSEDCL Vidyut Bhawan, 3 <sup>rd</sup> Floor, D-Block, Block-DJ, Sector-II, Bidhannagar, Kolkata-700091 Tel (O) : 033-23197445 Website: <a href="http://www.wbstedcl.in">www.wbstedcl.in</a> , Email: <a href="mailto:ceit@wbstedcl.in">ceit@wbstedcl.in</a>
<b>Contact Details of e- Procurement Portal Support Team:</b>	Chief Engineer, IT WBSEDCL Vidyut Bhawan, 3 <sup>rd</sup> Floor, D-Block, Block-DJ, Sector-II, Bidhannagar, Kolkata-700091 Tel (O) : 033-23197445 Website: <a href="http://www.wbstedcl.in">www.wbstedcl.in</a> , Email: <a href="mailto:ceit@wbstedcl.in">ceit@wbstedcl.in</a>



## Section – 2: Eligibility and Qualification Requirements

### 1. Eligibility Requirements:

Technical Part of the Bid shall be evaluated, interalia, as per **Section 3** based on their responsiveness to and Bidder's compliance with the Eligibility Requirements specified herein below:

1.1. Only firm that is a private entity, a state-owned entity, or an institution, legally established in India and countries listed by ADB to undertake design, supply and installation of the works mentioned in the scope of works under this RFB Document/ bidding document are eligible to bid (submit their Bid in response to RFB Notice/ NIT). The Bidder (alternatively referred to as the Contractor/Bidder) may be a proprietorship concern or a partnership firm operating in India and countries listed by ADB, or a registered entity in India and countries listed by ADB under the Companies Act, 1956, 2013 or LLP Act.

1.2. Any combination of such entities eligible as per 1.1 above, is also eligible to bid in the form of a joint venture (JV) as defined in **Section 3**, under an existing agreement. In the case of a joint venture, the number of members of the JV shall not exceed 02 (Two) and all members shall be jointly and severally liable for the execution of the entire Contract in accordance with the Contract terms. The JV shall nominate a Representative who shall have the authority to conduct all business for and on behalf of all the members of the JV during the Bidding process and, in the event the JV is awarded the Contract, during contract execution.

In case of JV, the bidding JV (also referred to as the Bidder) shall submit a Joint Deed of Undertaking in Technical Part of its bid, as per the format enclosed in **Section 4** of the RFB/ bidding document. No change in the structure / constitution of the JV shall be permitted at any stage during bidding or execution of the Contract in the event of award.

1.3. As an exception to the foregoing Clause 1.1 & 1.2 above:

- a. **Sanctions:** Firms, which includes any of the JV members in case of bidding Joint Venture as per Clause 1. 2 above, blacklisted by the Employer/ CPSEs or any of their subsidiaries / Government of India/ Government of WEST BENGAL / any Regulatory Authority or any Government of the Foreign Countries listed by ADB, as on the date of submission of Bid, are not eligible to bid.
- b. **Suspension:** Firm, which includes any of the JV members in case of bidding Joint Venture as per Clause 1. 2 above, under suspension by the Employer as the result of the operation of a Bid–Securing Declaration or Proposal-Securing Declaration, shall not be eligible to bid.
- c. **Prohibitions:** Firms, which includes any of the JV members in case of bidding Joint Venture as per Clause 1. 2 above, and individuals of a country or goods/ works/

services manufactured/ produced in a country shall be ineligible, if as a matter of law or official regulations, the Government of India prohibits commercial relations with that country.

1.4. A Bidder, and all partners constituting the Bidder, shall have the nationality of India or an eligible countries as listed by ADB . A Bidder shall be deemed to have the nationality of a country if the Bidder is a citizen or is constituted, incorporated, or registered, and operates in conformity with the provisions of the laws of that country. This criterion shall also apply to the determination of the nationality of proposed subcontractors or suppliers for any part of the Contract including related services.

To be eligible to bid, the Bidders must ensure compliance to the following, failing which they shall not be eligible:

*I.* Any bidder from India or a country listed by ADB will be eligible to bid only if the bidder is registered with the Competent Authority.

*II.* "Bidder" (Seller / Service Provider) means any person or firm or company, including any member of a consortium or joint venture (that is an association of several persons, or firms or companies), every artificial juridical person not falling in any of the descriptions of bidders stated hereinbefore, including any agency branch or office controlled by such person, participating in a procurement process.

*III.* "Bidder from India or a country which listed by ADB" for the purpose of this Order/ Rule means: -

- a.* An entity incorporated, established, or registered in such a country; or
- b.* A subsidiary of an entity incorporated, established, or registered in such a country; or
- c.* An entity substantially controlled through entities incorporated, established, or registered in such a country; or
- d.* An entity whose beneficial owner is situated in such a country; or
- e.* An Indian (or other) agent of such an entity; or
- f.* A natural person who is a citizen of such a country; or
- g.* A consortium or joint venture where any member of the consortium or joint venture falls under any of the above

*IV.* The beneficial owner for the purpose of (iii) above will be as under:

*1.* In case of a company or Limited Liability Partnership, the beneficial owner is the natural person(s), who, whether acting alone or together, or through one or more juridical person, has a controlling ownership interest or who exercises control through other means. Explanation—

- a.* "Controlling ownership interest" means ownership of or entitlement to more than twenty-five percent of shares or capital or profits of the company;
- b.* "Control" shall include the right to appoint majority of the directors or to control the management or policy decisions including by virtue of their shareholding or management rights or shareholders agreements or voting agreements;

*2.* In case of a partnership firm, the beneficial owner is the natural person(s) who, whether acting alone or together, or through one or more juridical person, has

ownership of entitlement to more than fifteen percent of capital or profits of the partnership;

3. In case of an unincorporated association or body of individuals, the beneficial owner is the natural person(s), who, whether acting alone or together, or through one or more juridical person, has ownership of or entitlement to more than fifteen percent of the property or capital or profits of such association or body of individuals;

4. Where no natural person is identified under (1) or (2) or (3) above, the beneficial owner is the relevant natural person who holds the position of senior managing official;

5. In case of a trust, the identification of beneficial owner(s) shall include identification of the author of the trust, the trustee, the beneficiaries with fifteen percent or more interest in the trust and any other natural person exercising ultimate effective control over the trust through a chain of control or ownership.

V. An Agent is a person employed to do any act for another, or to represent another in dealings with third person.

1.5. Employer reserves the right to request for any additional information and reserves the right to reject the Proposal of any Bidder, if in the opinion of Employer, the qualification data is incomplete, or the Bidder is found not qualified to satisfactorily perform the Contract.

1.6. For the purposes of these Bidding Documents, the words “facilities,” “plant and equipment,” “installation services,” etc., shall be construed in accordance with the respective definitions given to them in the General Conditions of Contract.

## 2. Qualification Requirements

### 2.1. Technical Qualifications:

Sl. No.	Criteria	Description	Submission Requirements
1	<b>General Experience</b>	<p>Bidder/ JV members (if any) should have successfully implemented Eligible Projects in any Indian/Global electricity distribution utility) during the last ten (10) financial years:</p> <ul style="list-style-type: none"> <li>i. Aggregate project value not less than (50%) of the Estimated Project Cost</li> <li>ii. With project value of one such Eligible Projects not less than (30%) of the Estimated Project Cost</li> </ul> <p style="text-align: center;"><b>OR</b></p> <p>Two such Eligible Projects not less than (20%) of the Estimated Project Cost</p> <p><i>Note: For calculation of project value of eligible projects, only project value of the portion of the project executed by the Sole/Lead Bidder shall be considered.</i></p>	Form 9
2	<b>Specific Project Experience</b>	<p>Bidder/JV members (if any) should have minimum experience in implementing Eligible Projects in the last 5 (Five) financial years –</p> <ul style="list-style-type: none"> <li>- One (1) project of project value greater than INR 30 Crores</li> <li>- OR, Two (2) projects of project value greater than INR 15 Crores each,</li> <li>- OR, Three (3) projects of project value greater than INR 10 Crore each</li> </ul> <p>The projects must encompass at least 2 (Two) of the below 3 (Three) mandatory components –</p> <ul style="list-style-type: none"> <li>A. On-Premise/Cloud Setup involving Servers, Storage, Network, and Enterprise Backup</li> </ul>	

		<p>Solution</p> <p>B. Implementation of 10G and above Networking Solution with Spine Leaf Architecture over a software Defined Network.</p> <p>C. Implementation of a DC to DRC lift-and-shift migration in X86 and RISC architecture.</p>	
<b>3</b>	<b>Certifications</b>	<p>Bidder/All JV Members (if any) must have the following certificates which should be valid on the date of bid submission:</p> <p>i. ISO 9001:2015</p> <p>ii. ISO 27001:2013 or latest (Bidders with 2013 certification should upgrade themselves to 2022)</p> <p>iii. ISO 20000-1:2018</p> <p>iv. CMMi Level 5</p>	Form 9
<b>4</b>	<b>Office location</b>	<p>The Bidder/Lead Bidder of the JV must have an office location in West Bengal/India for at least One (1) year prior to the submission of the bid.</p>	<p>Certificate of Incorporation/Registration Documents should be submitted as proof of the same.</p>
<b>5</b>	<b>Manufacturers Authorization Certificate</b>	<p>The Bidder/Lead Bidder of the JV must submit valid MAF certificates for all proposed hardware/software OEMs named in their submitted Technical bid</p>	<p>Manufacturers Certificate to be submitted as per Form 25</p>
<b>6</b>	<b>Certified resources for the Bidder</b>	<p>The Bidder/Lead Bidder for the JV shall have the following resources in their payroll with the following certifications –</p> <p>i. Two (2) Virtualization Service Expert with certification from the OEM named in their submitted Technical Bid</p> <p>ii. Two (2) Backup Solution Expert with certification from the OEM named in their submitted Technical Bid</p> <p>iii. Two (2) Networking Expert with certification from the OEM named in their submitted Technical Bid</p> <p>iv. Two (2) OS x86/RISC Expert</p>	<p>Bidder/Lead Bidder/JV partner certificate on company letterhead naming the proposed personnel with attached copies of valid certificates as on date of submission of the bid</p>

		with certification from the OEM named in their submitted Technical Bid (one of each)	
		v. Two (2) Cloud Security Expert with CCSK/EXIN (Certified Integrator Secure Cloud Services) certification	
<p>a) <i>References along with requisite contract/ Purchase Order (PO)/ Work Order (WO). The references should indicate client name, scope of work, Project start date – as per the format prescribed in Form 9;</i></p> <p>b) <i>Documentary evidence of completion of the Project or completion of Go-live status (i.e., Go-live certificate, UAT testing certificate etc.) of the respective project as per the definition of Go-Live/ UAT specified therein or other documentary evidence indicating completion (e.g., proof of payment received/ proof of asset capitalized in books of accounts (as applicable) and client certificate for supply of material or similar proofs) along with contact details of the client;</i></p> <p>c) <i>Client certificate and other documentation for implementation performance/ operation</i></p>			

## 2.2. Financial Qualifications:

Sl. No.	Criteria	Description	Submission Requirements
1	<b>Positive Net-worth</b>	<p>Sole Bidder/All of the JV Members (if any) must have positive net-worth in each of the last three (3) financial years.</p> <p><i>Net worth means the sum total of the paid up capital and free reserves (excluding reserves created out of revaluation) reduced by aggregate value of accumulated loses (including debit balance in profit and loss account for current year) and intangible assets</i></p>	Form 9
2	<b>Net-worth of Bidder</b>	<p>Net Worth of the Bidder shall be at least (80%) of the estimated project cost in all of the last three financial years.</p> <p>For the purpose of complying with the financial requirements, the following shall apply –</p> <p>In the event the Bidder is a JV</p> <p>a. The financial requirements stated above shall be met cumulatively by the members forming the JV.</p> <p>b. The Lead JV Partner shall</p>	Form 9

		<p>meet 51% of the above financial requirement criteria stated above.</p> <p>c. The JV members shall meet not less than 25% of financial requirement criteria stated above</p>	
<p><i>The Bidder shall attach copies of financial statements (balance sheets, including all related notes, and income statements) for the years required above complying with the following conditions:</i></p> <ul style="list-style-type: none"> <li><i>i. Must reflect the financial situation of the Bidder or member to a JV, and not sister or parent companies;</i></li> <li><i>ii. Historic financial statements must be audited by a certified chartered accountant;</i></li> <li><i>iii. Historic financial statements must be complete, including all notes to the financial statements;</i></li> <li><i>iv. Historic financial statements must correspond to accounting periods already completed and audited (no statements for partial periods shall be requested or accepted)</i></li> </ul>			

**2.3 Assessing Capacity of Bidder:**

The criteria for assessing capacity of bidder shall be as below:

**Requirement:** The bid capacity of the turnkey contractor, shall be equal to or more than the estimated cost of the tender. The same shall be assessed as per following formula:

**Bidding capacity = [A x N x 2] - B**

The value of A and B to be based on the entire business of the bidder.

- A: Maximum annual turnover in last 5 FYs (to be CA certified)

N: Years prescribed for work completion under tender, 2 years for this instant NIT.

- B: Value of existing commitments & ongoing works for which LOI, LOA have been issued (to be certified by the Company Secretary/ Whole-Time Director/ CEO of the bidder) plus commitments on account of any L1 declaration as part of the DISCOM tender opening.
- In case of JV, bid capacity of each JV partner will be considered in the ratio of their share in the JV agreement. The aggregate bid capacity of the JV will be sum of the proportionate bid capacities of individual partners. For example, if the share in JV agreement of three firms are 40%, 35% and 25% and the individual bid capacities are A, B and C respectively. Then the aggregate bid capacity of JV will be 40 % of A+ 35% of B+25% of C.
- Agreement entered into by the Joint Venture Partners shall be submitted with the bid indicating the share of each JV partner in the Joint Venture.

***Mechanism:*** The following mechanism shall be adopted to open the financial bids of multiple packages at around the same time:

1. Completion of technical evaluation of the packages and notification of the financial bid opening date with at least 2 days advance notice to the bidders
2. Bidders to submit the updated details of the bidding capacity, as on/ up to 7 days before the opening of financial bid,
- 3.
4. Financial bids of only those bidders shall be opened, that have requisite bidding capacity corresponding to the estimated value of RFB/ tender,
5. Before opening every financial Bid, the Bid Capacity of all bidders shall be assessed as per the defined bidding Capacity formula, and including the bid value of previous opened financial bid (if any) for which the bidder is L1.
6. The above process shall be repeated until opening of all the balance financial bids.

However, there might be cases wherein the bidder has bid capacity as per the estimated tender value, but LI quoted by the bidder takes it beyond its estimated capacity. Then in such cases, as far as bid capacity clause is concerned, the bidder shall still be considered for award.



## Section - 3: Instructions to Bidders and Bid Data Sheet

### A. Instructions to Bidders General

1. **Scope of Bid and Definitions**
  - 1.1 In connection with the Notice Inviting Tenders (NIT)/ Request for Bids (RFB) Notice specified in **Bid Data Sheet**, the Employer (named in the **Bid Data Sheet**) issues this RFB/ Bidding Document for the Design, Supply, and Installation of Plant (also referred to as the Scope of Work), as specified in **Section 6**, Employer's Requirement. The name and identification of the package for award of contract under this NIT/RFB is specified in **Bid Data Sheet**.
  - 1.2 Throughout this bidding document:
    - (a) **"Affiliate(s)"** means an individual or an entity that directly or indirectly controls, is controlled by, or is under common control with the Bidder.
    - (b) **"Applicable Law"** means the laws and any other instruments having the force of law in India, as may be issued and in force from time to time.
    - (c) **'Employer'/'Utility'** means the entity, as briefly described in **Bid Data Sheet**, that has issued the Request for Bids for award of the Contract for the Design, Supply, and Installation of Plant (also referred to as the Scope of Work), as specified in **Section 6**, Employer's Requirement.
    - (d) **"Bid"** means the Technical Part (first Envelope) and the Financial Part (Second Envelope) of its bid submitted by the Bidder who participates in the bidding in response to Notice Inviting Tenders (NIT)/ Request for Bids (RFB) Notice. It is alternatively also referred to as the tender.
    - (e) **"Bid Data Sheet (BDS)"** means an integral part of the **Instructions to Bidders (ITB)**

**Section 3**, that is used to reflect issues, details and conditions specific to the procurement, to supplement and/or modify the provisions of ITB.

- (f) **“Bidder”** means a legally established professional firm or an entity that may submit its Bid to the Employer in response to the RFB Notice/ NIT issued by the Employer, to provide/ provision the Plant to the Employer.
- (g) **“Contract”** means a legally binding written instrument entered between the Employer/ Utility and the successful Bidder, in the manner and in accordance with the RFB document/ bidding documents, for the Design, Supply and Installation of Plant (also referred to as the Scope of Work), and includes the Letter of Acceptance/ Notification of Award, the Contract Agreement, the General Conditions of Contract (GCC), the Special Conditions of Contract (SCC), and the Appendices and the documents attached thereto.
- (h) **“Day”** means a calendar day, unless otherwise specified as **“Business Day”**. A Business Day is any day that is an official working day of Employer. It excludes Employer’s official public holidays.
- (i) **“Government”** means the government of India or any country listed by ADB, State Government or Local Government of India or countries listed by ADB as applicable.
- (j) **“in writing”** means communicated in written form (e.g. by mail, e-mail, fax, including that distributed or received through the electronic-procurement system used by Employer).
- (k) **“Plant”, “Installation Services”, “Facilities” (also referred hereinafter as “Works”)** used herein shall have the same meaning as ascribed to them in **Section 7**.
- (l) **“ITB”** (this **Section 3** of the RFB/ Bidding Documents) means the Instructions to



Bidders that, along with other Sections, provides the Bidders with all information needed to prepare and submit their Bids.

- (m) **“Joint Venture (JV)”** means an association with or without a legal personality distinct from that of its members, of more than one entity/ firm where one member has the authority to conduct all business for and on behalf of any and all the members of the JV, and where the members of the JV are jointly and severally liable to Employer for the performance of the Contract. Whether or not bidding by Joint Venture is permitted, is specified in **BDS** and in **Section 2**.
- (n) **“RFB”** means the Request for Bids issued by Employer for the selection of the successful Bidder from amongst the bids submitted by bidders(s) who bid against and in response to the Request for Bids Notice (alternatively referred to as **Notice Inviting Tenders (NIT)**) under Two Envelope Single Stage Bidding Process.
- (o) **“Sub-contractor”** means an entity to whom the Contractor subcontracts any part of the Works as per the applicable provisions of the Contract while the Contractor remains responsible to Employer for the whole and successful performance of the Contract.
- (p) Capitalized terms used herein but not defined specifically shall have the meaning as ascribed to them in Section 5 and Section 6, and elsewhere in RFB/bidding Document.
- (q) if the context so requires, “singular” means “plural” and vice versa.
- (r) **“TPQMA”** means a “Third Party Quality Monitoring Agency” that the Nodal Agency for RDSS (REC/PFC) engages to carry out Pre-Dispatch inspection of materials at manufacturing facilities of Contractor or Sub Contractor / Sub-Vendors of the Contractor and to carry out

the inspection in the field of the works carried out in the RDSS scheme.

## 2. Fraud and Corruption

- 2.1 The Employer requires compliance with the Anti-Corruption Guidelines/ Laws in force of the relevant Government/ its instrumentalities/ Utility.
- 2.2 Bidders are also required to sign and furnish in the Bid, duly signed Integrity Pact if so specified in **ITB 10.2.8**.

## 3. Eligibility, Qualification Requirements

- 3.1 The eligibility and qualification requirements against the RFB are given in **Section 2**, for the Bidders and the Plant/ Installation Services/ Works . Bids, if any, from Bidders and/or offering Plant/ Installation Services/ Works not complying with the same shall be outrightly rejected and shall not be considered for evaluation
- 3.2 Bids submitted by the Bidders shall be evaluated to ascertain their compliance with Eligibility and Qualification Requirements, based on the details/ information/ documentary evidence pertaining to the same to be submitted in the Technical Part, as specified in ITB. All Bidders shall provide in **Section 4**, Bidding Forms, requisite details, and documents in support of meeting the Eligibility and Qualification Requirements. A Bid shall be rejected if the Bidder submitting the Bid, fails to meet the Eligibility and Qualification Requirements. Bids submitted by those Bidders who meet the Eligibility and Qualification Requirements shall be shortlisted for further evaluation of their bids.
- 3.3 A Bidder shall provide such additional documentary evidence of eligibility and/or qualification satisfactory to the Employer, as the Employer shall reasonably request.

## 4. Conflict of Interest

- 4.1 A Bidder shall not have a conflict of interest. Any Bidder found to have a conflict of interest shall be disqualified. A Bidder may be considered to have a conflict of interest for the purpose of this Bidding process, if the Bidder:

- (a) directly or indirectly controls, is controlled by or is under common control with another Bidder; or
  - (b) receives or has received any direct or indirect subsidy from another Bidder; or
  - (c) has the same legal representative as another Bidder; or
  - (d) has a relationship with another Bidder, directly or through common third parties, that puts it in a position to influence the Bid of another Bidder, or influence the decisions of the Employer regarding this Bidding process; or
  - (e) any of its affiliates participated as a consultant in the preparation of the design or technical specifications of the works that are the subject of the Bid; or
  - (f) any of its affiliates has been hired (or is proposed to be hired) by the Employer for the Contract implementation; or
  - (g) has a close business or family relationship with a professional staff of the Utility (or of the project implementing agency) who: (i) are directly or indirectly involved in the preparation of the bidding document or specifications of the Contract, and/or the Bid evaluation process of such Contract; or (ii) would be involved in the implementation or supervision of such Contract unless the conflict stemming from such relationship has been resolved in a manner acceptable to the Employer throughout the Bidding process and execution of the Contract.
- 4.2 A firm that is a Bidder (either individually or as a JV member) shall not participate as a Bidder or as JV member in more than one Bid. Such participation shall result in the disqualification of all Bids in which the firm is involved. However, this does not limit the participation of a Bidder as subcontractor in another Bid or of a firm as a subcontractor in more than one Bid.

## **B. Contents of Bidding Document**

## **5. Sections of Bidding Document**

5.1 The bidding document (also referred to as the RFB document) consist of Parts 1, 2, and 3, which include all the sections indicated below, and should be read in conjunction with any Addenda/ Corrigenda/ Amendments issued in accordance with **ITB 7**.

### **PART 1 Bidding Procedures and Requirements**

- Section 1 - Request for Bids Notice
- Section 2 - Eligibility and Qualification Requirements
- Section 3 - Instructions to Bidders and Bid Data Sheet
- Section 4 - Bidding Forms - Technical Part of the Bid
- Section 5- Bidding Forms - Financial Part of the Bid

### **PART 2 Employer's Requirements**

- Section 6 – Employer's Requirement

### **PART 3 Conditions of Contract and Contract Forms**

- Section 7 - Conditions of Contract
- Section 8 - Contract Forms

5.2 The Bidder is expected to examine all instructions, forms, terms, and specifications in the bidding document and to furnish with its Bid, all information or documentation as is required by the RFB/ bidding document.

## **6. Bidding Process Management, Clarification of the Bidding Document, Site Visit and Pre-Bid Meeting**

### **a) Electronic Procurement**

6.1 Electronic- Bidding System (also referred to as e-Procurement or e- Tendering system) as specified in the **BDS** shall be used to manage the bidding

process. Only the Bids which are submitted and received through the specified system in conformity with the procedures and requirements specified of **ITB** and **BDS** shall be considered.

**b) Clarifications to Bidding Documents**

6.2 The electronic- bidding system specified in the **ITB 6.1** provides for online clarifications. A Bidder requiring any clarification of the bidding document may notify the Employer online or through any other mode if so specified in **BDS**. Clarifications requested through any other mode shall not be considered by the Employer. The Employer will respond to any request for clarification, provided that such request is received prior to the deadline for submission of Bids within a period specified in the **BDS**. Description of clarification sought, and the response of the Employer shall be uploaded for information of all Bidders without identifying the source of request for clarification. Should the clarification result in changes to the essential elements of the bidding document, the Employer shall amend the bidding document following the procedure under **ITB 7** and **ITB 21.2**.

**c) Site Visit**

6.3 The Bidder is advised to visit and examine the Site where the Plant is to be installed/ Works are to be provided, and its surroundings and obtain for itself on its own responsibility all information that may be necessary for preparing the Bid and entering into a contract for provision of Plant and Installation Services/ construction of the Works. The costs of visiting the Site shall be at the Bidder's own expense.

6.4 The Bidder and any of its personnel or agents will be granted permission by the Employer to enter upon its premises and lands for the purpose of such visit, but only upon the express condition that the Bidder, its personnel, and agents will release and indemnify the Employer and its personnel and agents from and against all liability in respect thereof, and will be responsible for death or personal injury, loss of or damage to property, and any other loss, damage, costs, and expenses incurred as a result of the inspection.

**d) Pre-Bid Meeting**

6.5 If so specified in the **BDS**, the Bidder's designated representative is invited to attend a pre-Bid meeting. The purpose of the meeting will be to clarify issues



and to answer questions on any matter that may be raised at that stage.

6.6 The Bidder is requested to submit any questions in writing, to reach the Employer not later than one day before the meeting.

6.7 Minutes of the pre-Bid meeting, including the text of the questions raised without identifying the source, and the responses given, together with any responses prepared after the meeting, will be notified online through electronic-bidding system. Any modification to the bidding document that may become necessary as a result of the pre-Bid meeting shall be made by the Employer exclusively through the issue of an Addendum pursuant to **ITB 7** and not through the minutes of the pre-Bid meeting. Nonattendance at the pre-Bid meeting will not be a cause for disqualification of a Bidder.

## **7. Addenda/Corrigendum/ Amendment of Bidding Document**

7.1 At any time prior to the deadline for submission of Bids, the Employer may amend the bidding document by issuing addenda/ corrigendum/ amendment. The addendum/ corrigendum/ amendment will be in writing and appear on the e-procurement system and through email notification automatically sent to those bidders who have started working on the procurement, or as otherwise specified in **BDS**.

7.2 Any addendum/ corrigendum/ amendment issued shall be part of the bidding document and shall be deemed to have been communicated to all the bidders.

7.3 To give prospective Bidders reasonable time in which to take an addendum/ corrigendum/ amendment into account in preparing their Bids, the Employer may, at its discretion, extend the deadline for the submission of Bids, pursuant to **ITB 21.2**.

## **C. Preparation of Bids**

### **8. Cost of Bidding**

8.1 The Bidder shall bear all costs associated with the preparation and submission of its Bid, and the Employer shall not be responsible or liable for those costs, regardless of the conduct or outcome of the bidding process.

## 9. Language of Bid

9.1 The Bid, as well as all correspondence and documents relating to the Bid exchanged by the Bidder and the Employer, shall be written in English. Supporting documents and printed literature that are part of the Bid may be in another language provided they are accompanied by an accurate translation of the relevant passages into English, in which case, for purposes of interpretation of the Bid, such translation shall govern.

## 10. Documents comprising Bid

10.1 Under the Single Stage Two Envelope bidding process, the Bid shall comprise two Parts, namely the Technical Part and the Financial Part. These two Parts shall be submitted by the Bidder simultaneously.

10.2 The **Technical Part** shall contain the following:

10.2.1 **Letter of Bid - Technical Part:** prepared in accordance with **ITB 11**;

10.2.2 **Bid Security or Bid-Securing Declaration:** in accordance with **ITB 18**, prepared using the relevant form furnished in **Section 4 - Bidding Forms - Technical Part of the Bid**

10.2.3 **Authorization:** Document authorizing the signatory of the Bid to commit the Bidder, in accordance with **ITB 19.3 or ITB 19.4**, as may be applicable, prepared using the bidder's own format;

10.2.4 **Bidder's Eligibility:** documentary evidence in accordance with **ITB 16.1** establishing the Bidder's eligibility to Bid as per the requirements specified in Section 2/ Section 3;

10.2.5 **Qualifications:** documentary evidence in accordance with **ITB 16.2** establishing the Bidder's compliance to the Qualifications Requirements specified in Section 2/ Section 3, along with duly filled in form for compliance of Qualification Requirements, furnished in Section 4 - Bidding Forms - Technical Part of the Bid;

10.2.6 **Eligibility of Goods/ Works/ Plant and Installation Services:** documentary evidence in accordance with **ITB 16.1**, establishing the

eligibility of the Works to be supplied by the Bidder;

10.2.7 **Conformity:** Undertaking on Compliance of terms & conditions of the Bidding Documents including Scope of Services and other related requirements, towards documentary evidence in accordance with **ITB 15.1**, prepared using the relevant form furnished in **Section 4 - Bidding Forms - Technical Part of the Bid**; and

**10.2.8** any other document if required as per **BDS**.

10.2.9 In addition to the requirements as aforesaid, Bids submitted by a JV shall include a copy of the Joint Venture Agreement entered into by all members, a Joint Deed of Undertaking and Power of Attorney. The Joint Deed of Undertaking and the Power of Attorney shall be prepared using the relevant form furnished in **Section 4 - Bidding Forms - Technical Part of the Bid**

10.3 The **Financial Part** shall contain the following:

**10.3.1 Deleted**

10.3.2 **Price Schedules:** completed prepared in accordance with **ITB 11, ITB 13 and ITB 14**;

**10.3.3** any other document if required in **BDS**.

10.4 The Technical Part shall not include any financial information related to the Bid price. Where material financial information related to the Bid price is contained in the Technical Part the Bid shall be declared non-responsive.

## 11. Process of Bid Submission

- 11.1 The Letter of Bid – Technical Part shall be prepared using the relevant forms furnished in **Section 4 - Bidding Forms - Technical Part** of the Bid. The priced Schedules for the Plant and Installation Services/ Works shall be prepared using the relevant forms furnished in **Section 5 - Bidding Forms - Financial Part** of the Bid. The forms must be completed without any alterations to the text, except as provided under **ITB 19.3** for which the bidder can use its own format. All blank spaces shall be filled in with the information requested.
- 11.2 Entire Bid as per **ITB 10** including the Letters of Bid and filled-up priced Schedules for the Plant and Installation Services/ Works, shall be submitted online on e-procurement system specified in **ITB 6.1**. Details and process of online submission of the Bid/ tender and relevant documents are given in **ITB 6.1** and the concerned website referred therein.
- 11.3 **Submission of Original Documents:** The Bidders are also required to separately submit the hard copy of the documents, if any mentioned in **BDS**, at Employer’s address specified in **BDS**, so as to reach the office before the opening of the Technical Part of the Bid, either by registered/speed post/courier or by hand, failing which the bids are liable to be declared non-responsive.
- 11.4 Hard copy of rest of the Bid or any document, other than those specified in **ITB 11.3** are not to be submitted. Employer may, however, seek submission of hard copy of any of the other documents forming part of the Bid or any other supporting/ related document from any of the bidders during the process of evaluation of the Bids, without permitting change in substance of the Bid.

## 12. Alternative Bids

- 12.1 Alternative Bids are not permitted and shall not be considered.

## 13. Bid prices and Discounts

- 13.1 Unless otherwise specified **in the BDS**, Bidders shall quote for the entire Plant and Installation Services on a “single responsibility” basis. The total Bid price shall include all the Contractor’s obligations mentioned in or to be reasonably inferred from the bidding document in respect of the design, engineering, manufacture, including procurement and

subcontracting (if any), delivery, construction, installation and completion of the Plant. This includes all requirements under the Contractor's responsibilities for testing, pre-commissioning and commissioning of the plant and, where so required by the bidding document, the acquisition of all permits, approvals and licenses, etc.; the operation, maintenance and training services and such other items and services as specified in the bidding document, all in accordance with the requirements of the bidding documents.

13.2 Bidders are required to quote the price for the commercial, contractual and technical obligations outlined in the bidding document.

13.3 Bidders shall give a breakdown of the prices in the manner and detail called for in the Price Schedules included in **Section 5**. Bidding Forms – Financial Part of the Bid.

13.4 Depending on the Scope of the Work and the Contract, the Price Schedules shall comprise the schedules listed below. Bidders shall note that the plant and equipment included in Schedule Nos. 1 exclude materials used for civil, building and other construction works. All such materials shall be included and priced under Schedule No. 2, Installation Services. The Schedules comprise:

**Schedule No. 1:** Schedule No.1: Plant and Equipment including Mandatory Spares to be supplied

**Schedule No. 2:** Supply of Installation Services

**Schedule No. 3:** Design Services

**Schedule No. 4**

**Schedule No.5** Grand Summary

13.5 In the Schedules, Bidders shall give the required details and a breakdown of their prices as follows:

13.5.1 Supply of Plant (Schedule No. 1):

- (i) The price of the plant shall be quoted on FOR (final place of destination (Site/ Project Site) as specified in **BDS**) basis, and shall be inclusive of all costs, expenses, duties, taxes, and

other levies incidental thereto inter-alia including design, engineering, manufacture, testing, transportation, insurance etc. and other services, incidental thereto, as applicable, and taking into account any input tax credit except (ii) below;

- (ii) GST as percentage of the price as per (i) above, payable additionally by the Utility, applicable on the plant/goods/ material, if the contract is awarded to the Bidder, is pre-specified in Schedule No.1 and bidders are not required to quote the same separately anywhere in the bid. (Basis the same and the price quoted as per (i) above, the amount towards GST against each item shall get calculated accordingly); and
- (iii) The total price for the item i.e. (i) plus (ii) above.

#### 13.5.2 Supply of Installation Services (Schedule No. 2):

- (i) The price of Installation Services {excluding the incidental services included in 13.5.1 (ii)} shall be quoted separately and shall be inclusive of all costs, expenses, duties, taxes, and other levies related, inter-alia, to unloading and handling of plant, all labor, contractor's equipment, temporary works, materials, consumables, design and preparation of layout, engineering drawings, and all matters and things of whatsoever nature, including testing, pre-commissioning and commissioning, operations and maintenance services, the provision of as-built drawings, operations and maintenance manuals, training, etc., applicable and necessary for the proper execution of the installation

and other services, at final destination (Site/ Project Site) as specified in the **BDS**, related to and incidental to successful installation of the Plant, except (ii) below;

- (ii) GST as percentage of the price as per (i) above, payable additionally by the Utility, applicable on the Installation Services, if the contract is awarded to the Bidder, is pre-specified in Schedule No.2 and bidders are not required to quote the same separately anywhere in the bid (Basis the same and the price quoted as per (i) above, the amount towards GST against each item shall get calculated accordingly); and
- (iii) The total price for the item i.e. (i) plus (ii) above.

#### 13.5.3 Grand Summary (Schedule No. 3):

The total amount of each of the components from each of Schedule No.1 and Schedule No. 2 corresponding to the Plant and Installation Services, shall be summarized in the schedule titled Grand Summary, (Schedule 3). Aggregate of the total amount as per **ITB 13.5.1 (i)** and **ITB 13.5.2 (i)**, giving the total **Bid price**, excluding GST, is to be entered in the Letter of Bid. The total amount towards GST, that is aggregate of the total amount as per **ITB 13.5.1 (ii)** and **ITB 13.5.2 (ii)** is to be indicated separately in Schedule No. 3 and entered separately in the Letter of Bid .

#### 13.5.4 Recommended Spare Parts ( Schedule No. 4)

Recommended spare parts shall be quoted separately (Schedule 4) in the

manner and as specified in subparagraph 13.5.1 above along with support service.

- 13.5.5 The terms CIP, CIF, EXW, FOR and other similar terms shall be governed by the rules prescribed in the current edition of Incoterms, published by the International Chamber of Commerce.
- 13.5.6 Items against which no rate or price is entered by the Bidder shall be deemed covered by the rates for other items in the Price Schedule and will not be paid for separately by the Employer. An item not listed in the price schedule shall be assumed to be not included in the Bid, and provided that the Bid is determined substantially responsive notwithstanding this omission, the price as specified in **ITB 28.3**, will be added to the Bid price and the equivalent total cost of the Bid so determined will be used for price comparison.
- 13.6** The prices shall be either fixed or adjustable as specified in the **BDS**.
- 13.7 In the case of **Fixed Price**, prices quoted by the Bidder shall be fixed during the Bidder's performance of the contract and not subject to variation on any account. A Bid submitted with an adjustable price quotation will be treated as non-responsive and rejected.
- 13.8 In the case of **Adjustable Price**, prices quoted by the Bidder shall be subject to adjustment during performance of the contract to reflect changes in the cost elements such as labor, material, transport and Contractor/Bidder's equipment in accordance with the procedures specified in the corresponding **Appendix to the Contract Agreement**. A Bid submitted with a fixed price quotation will not be rejected, but the price adjustment will be treated as zero. If not already specified in **Appendix to the Contract Agreement stated above**, bidders are required to indicate the source of labor and material indices in the corresponding Form in **Section 4**. Bidding Forms – Technical Part of the Bid.
- 13.8.1 the Bidder shall be free to use transportation through carriers registered in India. Similarly,



the Bidder may obtain insurance services from India.

13.9 Bidders wishing to offer any unconditional price reduction (discount) for the award of the package (Contract), shall specify in their Letter of Bid the price reduction applicable to such package, and the manner in which the price reductions will apply. Any conditional discount shall not be considered for evaluation, however, the Employer may consider the same in case of award of Contract on the Bidder.

**13.10** The total amount as per **ITB 13.5.1 (i)** and **ITB 13.5.2 (i)**, from each of Schedule No.1 and Schedule No. 2, corresponding to the Plant and Installation Services, respectively, which shall be summarized in the schedule titled Grand Summary, (Schedule 3), and aggregated giving the total **Bid price(s)** of the Bidder, excluding GST and excluding any reduction/ discount offered, shall be brought/ carried forward and entered in the Letter of Bid. Considering reduction/ discount as per **ITB 13.9 and ITB 13.10** (if applicable), if offered, it shall constitute the quoted Bid price of the Bidder, excluding GST.

13.11 The total amount towards GST, that is aggregate of the amount quoted separately by the bidder as per **ITB 13.5.1 (ii)** and **ITB 13.5.2 (ii)**, shall be considered for evaluation and comparison of bids if so specified in ITB 32.1 (e), and it shall be payable/ reimbursable to the Bidder, in the event of award of contract, as specified in **BDS**.

#### **14. Currencies of Bid and Payment**

14.1 The prices shall be quoted by the Bidder, and shall be paid for by the Employer, entirely in Indian Rupees.

#### **15. Documents Establishing the Conformity of the Plant and Installation Services/ Works**

15.1 To establish the conformity of the Plant and Installation Services/ Works to the bidding document, the Bidder shall furnish as part of its Bid an Undertaking on Compliance of terms & conditions of the Bidding Documents including Scope of Work, conformance of Plant and Installation Services/ Works to the technical specifications and standards specified in **Section 6**, Employer's Requirement as well as other related requirements, in the Technical

Part of the bid as specified in **ITB 10.2.7**, as per the format given in **Section 4 - Bidding Forms - Technical Part of the Bid**.

- 15.2 Wherever and if specified in **Section 6 - Employer's Requirement**, the bidder shall also submit documentary evidence in the form of literature, drawings or data, and a detailed item by item description of the essential technical characteristics of the Plant and Installation Services/ Works, demonstrating substantial responsiveness of the Plant and Installation Services/ Works to the technical specification.
- 15.3 Wherever and if specified in **Section 6** , Employer's Requirement, the Bidder shall furnish in technical proposal a statement of work methods, equipment, personnel, schedule and any other information as stipulated in **Section 4, Bidding Forms – Technical Part of the Bid**, in sufficient detail to demonstrate the adequacy of the Bidder's proposal to meet the Employer's Requirements and the Time for Completion of the Plant and Installation Services/ Works.
- 15.4 Standards for workmanship, process, material, and equipment, as well as references to brand names or catalogue numbers specified by the Employer in the Employer's Requirement, are intended to be descriptive only and not restrictive. The Bidder may offer other standards of quality, brand names, and/or catalogue numbers, provided that it demonstrates, to the Employer's satisfaction, that the substitutions ensure substantial equivalence or are superior to those specified in the **Section 6, Employer's Requirement**.
- 15.5 For major items of Plant and Installation Services if and as listed by the Employer in **Section 2, Eligibility and Qualification Requirements and Section 6, Employer's Requirement**, which the Bidder intends to purchase or subcontract, the Bidder shall give details of the name and nationality of the proposed Subcontractors, including manufacturers, for each of those items. In addition, the Bidder shall include in its Bid information establishing compliance with the requirements specified by the Employer for these items. Quoted rates and prices will be deemed to apply to

whichever Subcontractor is appointed, and no adjustment of the rates and prices, on this account, will be permitted.

15.6 The Bidder shall be responsible for ensuring that any Subcontractor proposed complies with the requirements of **Section 2** and **Section 6**.

**16. Documents Establishing the Eligibility and Qualifications of the Bidder and Eligibility of Plant and Installation Services**

16.1 To establish Bidder's eligibility and eligibility of Plants and Installation Services/ Works in accordance with **ITB 3** and **Section 2**, Eligibility Requirements, Bidders shall complete the Letter of Bid – Technical Part, and other forms included in **Section 4 - Bidding Forms - Technical Part of the Bid**.

16.2 The documentary evidence of the Bidder's eligibility and qualifications, and eligibility of Plant and Installation Services, to be furnished as per **Section 4 - Bidding Forms - Technical Part of the Bid**, for the Bidder to be considered for award of the Contract, shall establish to the Employer's satisfaction that the Bidder meets each of the Eligibility and Qualification Requirements and establishes eligibility of Plant and Installation Services/ Works, specified in **ITB 3 and Section 2**.

**17. Period of Validity of Bids**

17.1 Bids shall remain valid until the date specified in the **BDS** or any extended date if amended by the Employer in accordance with **ITB 7**. The Bid Validity period starts from the Bid submission deadline (as prescribed by the Employer in accordance with **ITB 21.1**). A Bid that is not valid until the date specified in the **BDS**, or any extended date if amended by the Employer in accordance with **ITB 7**, shall be rejected by the Employer as nonresponsive.

17.2 In exceptional circumstances, prior to the expiry of the Bid validity, the Employer may request Bidders to extend the period of validity of their Bids. The request and the responses shall be made in writing. If a Bid Security is requested (in accordance with **ITB 18**), it shall also be extended for a corresponding period. A Bidder may refuse the request without forfeiting its Bid Security. A Bidder granting the request shall not

be required or permitted to modify its Bid, except as provided in this **ITB 17.2**.

### **18. Bid Security/ Bid Securing Declaration**

18.1 Unless otherwise the provision for submission of Bid Securing Declaration is specified in the **BDS**, the Bidder shall furnish as part of the Technical part of its Bid, a Bid security in original form, and in the amount specified in the BDS.

18.2 If a Bid Security is specified pursuant to **ITB 18.1**, the Bid Security shall be a demand guarantee, and in any of the following forms at the Bidder's option:

- (a) an unconditional guarantee issued by a nationalized/ scheduled commercial bank located in India;
- (b) a cashier's or certified check or demand draft from a Nationalized/ Scheduled commercial bank located in India; or
- (c) another form security, if specified in the **BDS**.

In the case of a bank guarantee, the Bid security shall be submitted using the Bid Security Form included in Section 4, Bidding Forms - Technical Part of the Bid. The form must include the complete name of the Bidder. The Bid Security shall be valid for ninety (90) days beyond the original validity period of the Bid, or beyond any period of extension if requested under **ITB 17.2**.

18.3 If a Bid Security is specified pursuant to **ITB 18.1**, any Bid not accompanied by a substantially responsive Bid Security shall be rejected by the Employer as non-responsive.

18.4 If a Bid Security is specified pursuant to **ITB 18.1**, the Bid Security of unsuccessful Bidders shall be returned as promptly as possible upon the successful bidder's signing the contract and furnishing the Performance Security pursuant to **ITB 43** and **ITB 45**.

18.5 The Bid Security of the successful bidder shall be returned as promptly as possible once the

successful bidder has signed the Contract and furnished the required Performance Security.

18.6 The Bid Security may be forfeited, or action may be taken as per the Bid Securing Declaration:

- (a) if a Bidder withdraws/modifies/substitutes its Bid during the period of Bid validity specified by the Bidder in the Letter of Bid - Technical Part, or any extension thereto provided by the Bidder; or if the Bidder does not accept the correction of its Bid Price pursuant to **ITB 33**; or
- (b) if the successful Bidder fails to:
  - (i) sign the Contract in accordance with **ITB 43**; or
  - (ii) furnish a performance security in accordance with **ITB 44**.

18.7 The Bid Security or the Bid-Securing Declaration of a JV shall be in the name of the JV that submits the Bid.

**18.8** If a Bid Security is not specified pursuant to **ITB 18.1** and Bid Securing Declaration is specified: and

- (a) if a Bidder withdraws its Bid during the period of Bid validity specified by the Bidder on the Letter of Bid Form, except as provided in **ITB 17.2**; or
- (b) if the successful Bidder fails to:
  - (i) sign the Contract in accordance with **ITB 43**; or
  - (ii) furnish a Performance Security in accordance with **ITB 44**;

the Employer may, declare the Bidder disqualified to be awarded a contract by the Employer for a period of time as stated in the **BDS**.

## **19. Format and Signing of Bid**

**19.1** The Bidder shall prepare the Bid, in accordance with **ITB 10** .

19.2 Bidders shall mark as “CONFIDENTIAL” information in their Bids which is confidential to their business. This may include proprietary information, trade

secrets, or commercial or financially sensitive information.

- 19.3 The Bid shall be signed by a person or persons duly authorized to sign on behalf of the Bidder. This authorization shall be in the form of the document as specified in **BDS** and shall be submitted/ uploaded along with the Bid as per **ITB 11**.
- 19.4 In the case that the Bidder is a JV, the Bid shall be signed by an authorized representative of the JV on behalf of the JV, and so as to be legally binding on all the members as evidenced by a power of attorney signed by their legally authorized representatives, which shall be submitted/ uploaded along with the Bid as per **ITB 11**.
- 19.5 Corrections, if any, can be carried out by editing the information before electronic submission on e-procurement portal.

#### **D. Submission of Bids**

#### **20. Submission of Bids**

- 20.1 Bids, both Technical and Financial Parts, shall be submitted online on the e-procurement system specified in **ITB 6.1**. Detailed guidelines for viewing bids and submission of online bids are as per **ITB 6.1** and the website referred therein. A prospective bidder can submit its bid online only for which the bidder (in case of JV, the authorised representative of the JV as per **ITB 19.4**) is required to have enrolment/registration and should have valid Digital Signature Certificate (DSC) as specified in **ITB 6.1** in **BDS**. The Bidder should go through them carefully and submit its bid, along with the specified documents failing which the bid is liable to be rejected.
- 20.2 The completed Bid comprising of documents indicated in **ITB 10**, should be uploaded on the e-procurement portal along with scanned copies of requisite certificates/ documents as are mentioned in different sections in the bidding document. Further, if so specified in **ITB 11.3**, the Bidders shall ensure submission of hard copy of documents as mentioned therein.

20.3 All the uploaded documents are required to be signed digitally by the bidder.

20.4 Physical, e-mail, Telex, Cable or Facsimile bids will be rejected as non-responsive.

## **21. Deadline for Submission of Bids**

21.1 Bids must be uploaded online, and if so specified in **ITB 11.3**, the hard copy of specified documents must be delivered at the address mentioned therein, no later than the deadline for submission of Bids i.e. the date and time specified in the **BDS**.

21.2 The Employer may, at its discretion, extend the deadline for the submission of Bids by amending the bidding document in accordance with **ITB 7**, in which case all rights and obligations of the Employer and Bidders previously subject to the deadline shall thereafter be subject to the deadline as extended.

## **22. Late Bids**

22.1 The electronic bidding system would not allow any late submission of bids after due date & time as per server time.

## **23. Withdrawal, Substitution, and Modification of Bids**

23.1 Bidders may modify their bids by using the appropriate option for bid modification on e-procurement portal before the deadline for submission of bids. For this the bidder need not make any additional payment towards the cost of bid document, if applicable. For bid modification and consequential re-submission, the bidder is not required to withdraw his bid submitted earlier. The last modified bid submitted by the bidder within the bid submission time shall be considered as the Bid. For this purpose, modification/withdrawal by other means will not be accepted. In online system of bid submission, the modification and consequential re-submission of bids is allowed any number of times. A bidder may withdraw his bid by using the appropriate option for bid withdrawal, before the deadline for submission of bids, however, if the bid is withdrawn, re-submission of the bid is allowed only upto the deadline for submission of bids as specified in **ITB 21**.

23.2 Bids requested to be withdrawn in accordance with **ITB 23.1** shall not be opened.

23.3 No Bid may be withdrawn, substituted, or modified in the interval between the deadline for submission of Bids and the expiration of the period of Bid validity specified by the Bidder on the Letter of Bid (Technical Part), or any extension thereof. This will result in the forfeiture of the Bid Security or be sufficient ground for action by Employer against the bidder under the Bid Securing Declaration, as may be applicable pursuant to **ITB 18**.

## **E. Public Opening of Technical Parts of Bids**

### **24. Public Opening of Technical Parts of Bids**

24.1 The Employer shall, at the Bid opening, publicly open online the Technical Parts of all Bids, except as in the cases specified in **ITB 22** and **ITB 23.2**, received by the deadline of bid submissions as specified in **ITB 21**, at the date, time and place specified in the **BDS** in the presence of Bidders' designated representatives who choose to attend, and this could also be viewed by the bidders online. The Financial Parts of the bids shall remain unopened in the e-procurement system, until the subsequent public opening, following the evaluation of the Technical Parts of the Bids. Bidder's names, and such other details as the Employer may consider appropriate will be notified by the Employer at the time of bid opening.

24.2 Only Technical Parts of Bids that are opened at Bid opening of Technical Parts shall be considered further for evaluation.

24.3 At the Bid opening the Employer shall neither discuss the merits of any Bid nor reject any Bid (except the cases, in accordance with **ITB 22** and **ITB 23.2**).

24.4 The Employer shall prepare a record of the Bid opening, that shall include, as a minimum:

- (a) the name of the Bidder; and
- (b) the presence or absence of a Bid Security or a Bid-Securing Declaration.

24.5 The Bidders' representatives who are present shall be requested to sign the record. The omission of a Bidder's signature on the record shall not invalidate the contents and effect of the record. A copy of the record shall be distributed to all Bidders.



## F. Evaluation of Bids - General Provisions

- 25. Confidentiality**
- 25.1 Information relating to the evaluation of Bids and recommendation of contract award, shall not be disclosed to Bidders, or any other persons not officially concerned with the Bidding process.
- 25.2 Any effort by a Bidder to influence the Employer in the evaluation or contract award decisions may result in the rejection of its Bid.
- 25.3 Notwithstanding **ITB 25.1**, from the time of Bid opening to the time of Contract Award, if any Bidder wishes to contact the Employer on any matter related to the Bidding process, it should do so in writing.
- 26. Clarification of Bids**
- 26.1 To assist in the examination, evaluation, comparison of the Bids, and eligibility or qualification of the Bidders, the Employer may, at its discretion, ask any Bidder for a clarification of its Bid and/or seek information related to historical data/ documents pertaining to credentials of the Bidders and the Bids, that the Employer may require. Any clarification submitted by a Bidder in respect to its Bid and that is not in response to a request by the Employer shall not be considered. The Employer's request for clarification and the response shall be in writing. No change, including any voluntary increase or decrease, in the prices or substance of the Bid shall be sought, offered, or permitted.
- 26.2 If a Bidder does not provide clarifications of its Bid or data/ documents sought, by the date and time set in the Employer's request for clarification/ data/ document, its Bid may be rejected.
- 27. Deviations, Reservations, and Omissions**
- 27.1 During the evaluation of Bids, the following definitions apply:
- (a) "Deviation" is a departure from the requirements specified in the bidding document;
  - (b) "Reservation" is the setting of limiting conditions or withholding from complete acceptance of the requirements specified in the bidding document; and

(c) "Omission" is the failure to submit part, or all of the information or documentation required in the bidding document.

**28. Nonmaterial  
Nonconformities, Errors  
and Omissions**

28.1 Provided that a Bid is substantially responsive, the Employer may waive any nonconformities in the Bid, which do not constitute a material deviation, reservation or omission.

28.2 Provided that a Bid is substantially responsive, the Employer may request that the Bidder submit the necessary information or documentation, within a reasonable period of time, to rectify nonmaterial nonconformities or omissions in the Bid related to documentation requirements. Requesting information or documentation on such nonconformities and/or omissions shall not be related to any aspect of the price of the Bid. Failure of the Bidder to comply with the request may result in the rejection of its Bid.

28.3 Provided that a Bid is substantially responsive, the Employer shall rectify quantifiable nonmaterial nonconformities related to the Bid Price. To this effect, the Bid Price shall be adjusted, for comparison purposes only, to reflect the price of a missing or non-conforming item or component in the manner specified in **BDS**.

**G. Evaluation of Technical Parts of Bids**

**29. Evaluation of Technical  
Parts**

29.1 In evaluating the Technical Parts of each Bid, the Employer shall use the requirements, criteria and methodologies mentioned and specified in **Section 2, Section 3** and **Section 6**.

29.2 The Employer shall, interalia, carry out the Technical Evaluation as per **ITB 29.3**, and determine to its satisfaction:

(a) whether the Bidders comply with the Eligibility Requirements, have offered eligible Plant and Installation Services in their Bids, as specified in **ITB 3** and **Section 2**;

(b) whether the Bidders meet the Qualification Requirement as specified in **ITB 3** and **Section 2**. (The determination shall be based upon an examination of the documentary evidence of the Bidder's qualifications submitted by the Bidder,

pursuant to **ITB 16** read in conjunction with **ITB 26**. The determination shall not take into consideration the qualifications of other firms such as the Bidder's subsidiaries, parent entities, affiliates, subcontractor/Bidders (other than specialized subcontractor/Bidders if permitted in the bidding document), or any other firm different from the Bidder that submitted the Bid except if provided in the specified Qualification Requirement itself and

- (c) whether the Bids submitted by the Bidders complying with the requirements specified in (a), and (b) above have been determined to be substantially responsive to the RFB/bidding document, as per **ITB 30**.

**29.3 Technical Evaluation.** The Employer will carry out a detailed technical evaluation of the Bids not previously rejected to determine whether the technical aspects are in compliance with the bidding document. The Bid that does not meet minimum acceptable standards of completeness, consistency and detail, and the specified minimum (or maximum, as the case may be) requirements for specified functional guarantees, will be rejected for non-responsiveness. In order to reach its determination, the Employer will examine and compare the technical aspects of the Bids on the basis of the information supplied by the Bidders, taking into account the following:

- (a) overall completeness and compliance with the Employer's Requirements; conformity of the Plant and Installation Services offered with specified performance criteria, including conformity with the specified minimum (or maximum, as the case may be) requirement corresponding to each functional guarantee, as indicated in **Section 2** and/ or **Section 6**; suitability of the Plant and Installation Services offered in relation to the environmental and climatic conditions prevailing at the site; and quality, function and operation of any process control concept included in the Bid;

- (b) type, quantity and long-term availability of mandatory and recommended spare parts and maintenance services; and
- (c) other relevant factors, if any, listed in the RFB/ bidding document.

29.4 At this stage, a Bid shall be rejected if the determination on any one of the aspects listed in ITB 29.2 (a), (b) and (c) above, is not in the affirmative. All other Bids shall be considered for further evaluation.

### **30. Determination of Responsiveness**

30.1 The Employer's determination of a Bid's responsiveness is to be based on the contents of the Bid itself, as defined in **ITB 10** read in conjunction with **ITB 26** and submitted as per **ITB 11**.

30.2 A substantially responsive Bid is one that meets the requirements of the bidding document without material deviation, reservation, or omission. A material deviation, reservation, or omission is one that:

- (a) if accepted, would:
  - (i) affect in any substantial way the scope, quality, or performance of the Works specified in the Contract; or
  - (ii) limit in any substantial way, inconsistent with the bidding document, the Employer's rights or the Bidder's obligations under the Contract; or
- (b) if rectified, would unfairly affect the competitive position of other Bidders presenting substantially responsive Bids.

30.3 The Employer shall examine the technical aspects of the Bids, in particular, to confirm that all requirements of **Section 6**, Employer's Requirement have been met without any material deviation or reservation, or omission.

30.4 If a Bid is not substantially responsive to the requirements of bidding document, it shall be rejected by the Employer and may not subsequently be made responsive by correction

of the material deviation, reservation, or omission.

## **H. Public Opening of Financial Parts of Bids**

### **31. Public Opening of Financial Parts**

31.1 Following the completion of the evaluation of the Technical Parts of the Bids, the Employer shall notify in writing those Bidders whose Bids were considered non-responsive to the bidding document / RFB Document or failed to meet the Eligibility Requirements or Qualification Requirement or any other specified requirement, advising them of the following information:

(a) the grounds on which their Technical Part of Bid failed to meet the requirements of the bidding document; and

(b) Financial Part of their Bid will not be opened.

31.2 The Employer shall, simultaneously, notify in writing those Bidders whose Technical Parts have been evaluated as substantially responsive to the bidding document and met the Eligibility Requirement, Qualification Requirement and other specified requirement, advising them of the following information:

(a) their Bid has been evaluated as substantially responsive to the requirements of bidding document and the specified requirements;

(b) Financial Part of their Bid will be opened online at the public opening of the Financial Parts; and

(c) notify them of the date, time and location of the second public opening of the Financial Parts of bid, and the address thereof. In the event of the specified date of bid opening being declared a holiday for the Employer, the bids will be opened at the appointed time and location on the next working day.

31.3 All efforts may be made to have the opening date that should allow Bidders sufficient time to make arrangements for attending the opening if they so choose, however as the opening is in online mode and bidder's get due notification of bid opening and can witness the opening online, the date of opening may be set accordingly based on

Employer's requirements. The Financial Part of the Bids shall be opened publicly in the presence of Bidders' designated representatives who chooses to attend, and this could also be viewed by the bidders online. The bidder's names, the Bid prices, the total amount of each bid, and such other details as the Employer may consider appropriate, will be announced by the Employer at the time of bid opening.

31.4 The Employer shall prepare a record of the Bid opening, that shall include, as a minimum:

- (c) the name of the Bidder; and
- (d) the Bid price, including any discounts

31.5 Only Financial Parts of Bids that are opened at Bid opening shall be considered for further evaluation.

## I. Evaluation of Financial Parts of Bids

### 32. Evaluation of Financial Parts

32.1 To evaluate the Financial Part of each Bid, the Employer shall consider the following:

- (a) Bid price, as quoted in accordance with **ITB 13.5**;
- (b) price adjustment for correction of arithmetic errors in accordance with **ITB 33**;
- (c) price adjustment due to discounts offered in accordance with **ITB 13.9**;
- (d) price adjustment due to quantifiable nonmaterial nonconformities in accordance with **ITB 28.3**;
- (e) GST, quoted separately as per **ITB 13.12**, adjusted for correction of arithmetic errors in accordance with **ITB 33**, shall be considered for arriving at the evaluated Bid cost/ price and comparison of Bids, except if otherwise specified in **BDS**.

- (f) the additional evaluation factors if specified in **BDS** and/ or **Section 6**.
- 32.2 If price adjustment is allowed in accordance with **ITB 13.6**, the estimated effect of the price adjustment provisions of the Conditions of Contract, applied over the period of execution of the Contract, shall not be taken into account in Bid evaluation.
- 32.3 The Employer's evaluation of a Bid may require the consideration of other factors if specified in **BDS**, in addition to the Bid price quoted, in accordance with **ITB 33.1 (e)**.
- 33. Correction of Arithmetical Errors**
- 33.1 The e-procurement system automatically calculates the total amount from unit rates and quantities, and the system also automatically populates the amount in words from the amount in figures, and therefore there is no scope of discrepancy and need for arithmetic correction. However there would be a manual recalculation and in the case of discrepancy between system generated and manual prices, the manually calculated prices shall prevail.
- 33.2 Any bid which is found to have tampered or modified the electronic logic of the e- procurement system for calculating the total amount from unit rates and quantities, and/ or in populating the amount in words from the amount in figures, is liable to be rejected and the case shall be dealt against the bidder under the Integrity Pact and conditions of the RFB/ bidding documents including those regarding fraud etc..
- 34. Comparison of Financial Parts**
- 34.1 The Employer shall compare the evaluated price/costs of all substantially responsive Bids, to determine the Bid that has the lowest evaluated cost/ price.
- 35. Preference**
- 35.1 Purchase Preference shall not apply for award of contract if not so specified in the **BDS**, as per the guidelines, instruction and methodology indicated therein.
- 36. Abnormally Low Bids**
- 36.1 An Abnormally Low Bid is one where the Bid price, in combination with other elements of the Bid, appears so low that it raises material concerns

with the Employer as to the capability of the Bidder to perform the Contract for the offered Bid Price.

36.2 In the event of identification of a potentially Abnormally Low Bid, the Employer, unless otherwise specified in **BDS**, may seek written clarification from the Bidder, including a detailed price analyses of its Bid price in relation to the subject matter of the contract, scope, delivery schedule, allocation of risks and responsibilities and any other requirements of the bidding document.

36.3 After evaluation of the price analyses, in the event that the Employer determines that the Bidder has failed to demonstrate its capability to perform the contract for the offered Bid price, the Employer shall reject the Bid.

### **37. Unbalanced or Front Loaded Bids**

37.1 The Bid that is evaluated as the lowest evaluated cost/price, shall be considered by the Employer as unbalanced or front loaded, if the quoted price of supply portion exceeds the percentage specified in **BDS** of the total quoted **Bid price**, after evaluation and excluding GST. In such a case, The bidder shall be required to furnish an additional performance security pursuant to **ITB 44.1** as contract.

### **38. Most Advantageous Bid**

38.1 Having compared the evaluated cost/price of Bids as per **ITB 34**, and applying the provisions of **ITB 35**, the Employer shall determine the Most Advantageous Bid (alternatively referred to as **L1 Bid**). The Most Advantageous Bid is the Bid of the Bidder (also referred to as the **successful bidder**) who meets the specified requirements as per **Section 2** and **Section 3**, and whose Bid has been determined to have the lowest evaluated price/cost subject to **ITB 35**.

38.2 The capabilities of the manufacturers and subcontractors proposed in its Bid to be used by the Bidder with the Most Advantageous Bid for identified major items of supply or services may also be evaluated for acceptability in accordance with **Section 2 / Section 6**. Their participation should be confirmed with a letter of intent between



the parties, as needed. Should a manufacturer or subcontractor be determined to be unacceptable, the Bid will not be rejected, but the Bidder will be required to substitute an acceptable manufacturer or subcontractor without any change to the Bid price. Prior to signing the Contract, the corresponding **Appendix** to the Contract Agreement shall be completed, listing the approved manufacturers or subcontractors for each item concerned.

**38.3 Price Negotiation** - Usually, there shall be no price negotiations. However, in case the Employer identifies exceptional reasons due to which negotiation is required, the Employer reserves its right to negotiate with the lowest acceptable bidder (L-1).

**39. Employer's Right to Accept Any Bid, and to Reject Any or All Bids**

39.1 The Employer reserves the right to accept or reject any Bid, and to annul the Bidding process and reject all Bids at any time prior to Contract Award, without thereby incurring any liability to Bidders. In case of annulment, all Bids submitted and specifically, Bid securities, if applicable as per **ITB 18** and submitted, shall be promptly returned to the Bidders.

**J. Award of Contract**

**40. Award Criteria**

40.1 The Employer shall award the Contract to the successful Bidder. This is the Bidder whose Bid has been determined to be the Most Advantageous Bid as specified in **ITB 38**.

40.2 The mode of contracting with the successful bidder will be as indicated below:

40.2.1 The award shall be made as follows:

(i) Contract Part I: for Supply of Plant on FOR (final place of destination Site/ Project Site) basis.

(ii) Contract Part II: for Supply of Installation Services {excluding the incidental services included in (i) above}

40.3 Both the parts of the Contract will contain a cross fall breach clause specifying that breach of one will constitute breach of the other.

**41. Employer's Right to make minor adjustments at the time of Award**

41.1 At the time the Contract is awarded, the Employer reserves the right to invite the Bidder whose Bid is determined to be the Most Advantageous Bid as per **ITB 38**, for discussions if any minor adjustments in the Contract are required, without any substantial change in the terms and conditions of the bidding document.

**42. Notification of Award**

42.1 Prior to the date of expiry of the Bid validity, the Employer shall notify the successful Bidder, in writing, that its Bid has been accepted. The Notification of Award (hereinafter and in the Contract Forms also called the "**Letter of Acceptance**") shall specify the sum that the Employer will pay the Contractor in consideration of the execution of the Contract (hereinafter and in the Conditions of Contract and Contract Forms called "the Contract Price").

42.2 Until a formal Contract is prepared and executed, the Letter of Acceptance/ Notification of Award shall constitute formation of a binding Contract.

**43. Signing of Contract**

43.1 Promptly upon issue of Letter of Acceptance/ Notification of Award, the Employer shall prepare the Contract Agreement, and keep it ready in the office of the Employer for the signature of the Employer and the successful Bidder, within twenty-one (21) days following the date of Letter of Acceptance. The Contract Agreement shall incorporate all agreements including L2 schedule between the Employer and the successful Bidder. L-2 schedule should be submitted, discussed, amended (if so required) within overall L-1 schedule and accepted by owner before signing of contract agreement. Also, CPG should be submitted, verified from issuing bank legally vetted and approved before signing of contract agreement.

43.2 Within twenty-eight (28) days of receipt of Letter of Acceptance, the successful Bidder shall (a) furnish the performance security in accordance with **ITB Clause 44**; and (b) shall sign, date and return the Agreement to the Employer along with the documents stated at (a) above.

## H. Performance Security & Funds

### 44. Performance Security

44.1 Within twenty-eight (28) days of the receipt of the Letter of Acceptance/ Notification of Award from the Employer, the successful Bidder shall furnish the Performance Security & Additional performance security (if applicable), in Indian Rupees, in accordance with the GCC and in the amount, form and details specified in the **BDS**, further subject to **ITB 37**.

44.2 Failure of the successful Bidder to submit the above-mentioned Performance Security & Additional performance security (if applicable) or sign the Contract shall constitute sufficient grounds for the annulment of the award and forfeiture of the Bid Security or be sufficient ground for action by the Employer against the bidder under the Bid Securing Declaration, as may be applicable as per **ITB 18**.

### 45. Source of Funds

45.1 The Employer named in the Bidding Documents intends to use the loan funds from ADB.

**46. Dedicated bank account of Contractor**

~~46.1 If required by the Employer, the Contractor may be required to create a dedicated bank account for usage of the funds under the project, the Contractor may be required to provide the details of the transactions under this account to the Employer at the time of key milestones as defined by the employer. Deleted.~~

## I. Bid Data Sheet (BDS)

The following specific data for the Plant and Installation Services/ Works to be procured shall complement, supplement, and/or amend the provisions in the Instructions to Bidders (ITB). Whenever there is a conflict, the provisions herein shall prevail over those in ITB.

ITB Reference	A. General
<b>ITB 1.1</b>	<p>The reference number of the Notice Inviting Tenders (NIT/Request for Bids (RFB) is : <b>WBSEDCL/IT&amp;C/114.00(RDSS)/2527 Dated 28.02.2024</b></p> <p>The Employer is: <b>West Bengal State Electricity Distribution Company Limited.</b></p>
<b>ITB 1.2</b>	<p>(s) <b>Eligible Projects</b> shall mean any Turnkey IT System Upgradation and/or Integration (TSI) projects for DC/DRC/Cloud infrastructure including supply of Hardware/Cloud components/services, supply of Software licenses along with network upgradation, installation, configuration, customization, implementation/ Go-Live along with providing FMS / AMC services / System Operation services in electricity distribution utility.</p>
<b>ITB 1.2 (c)</b>	<p>The Government of West Bengal unbundled the erstwhile West Bengal State Electricity Board (WBSEB) into two companies viz., West Bengal State Electricity Distribution Company Limited (WBSEDCL) and West Bengal State Electricity Transmission Company Limited (WBSETCL).</p> <p>The main business of WBSEDCL is distribution and hydro generation of electricity. It is also the nodal Agency of the Government of West Bengal for undertaking Rural Electrification task in the State with objective of providing access of electricity to all rural households in the state in line with the National Rural Electrification Policy.</p>
<b>ITB 1.2 (m)</b>	<p>Bidding/ Bids by/ from Joint Venture (JV) is “permitted”.</p> <p>In case Bidding/ Bids by/ from Joint Venture is permitted, the number of members/ partners of the JV shall not exceed 03 (three)</p>
	<b>B. Contents of Bidding Document</b>

<b>ITB 6.1</b>	<p><b>Bidding against RFB shall be conducted through/ with Electronic – Procurement (e- Procurement/ e- Tendering) System.</b></p> <p>Employer shall use the following Electronic-Procurement system to manage this Request for Proposal (RFP) process:</p> <p><b><u><a href="http://www.wbtenders.gov.in">www.wbtenders.gov.in</a></u></b></p> <p>The electronic-procurement system shall be used to manage the following part of the bidding process under the RFB:</p> <p><b>Issuing RFB/ Bidding document, amendments/ corrigendum/ addendums/ clarifications, etc., submissions of bids, opening of Bids,etc.</b></p>
----------------	--

	To aid and facilitate the Bidders on e-Procurement/ e-Tendering process a detailed manual on the same titled <b>Bidder Help Manual for e-Bidding</b> has been provided annexed to the Bid Data Sheet as <b>Annexure I (BDS)</b> . The same may be utilized by the Bidders.
<b>ITB 6.2</b>	A Bidder requiring any clarification of the bidding document may notify the Employer online through the electronic bidding system if provisioned/ permitted or through e-mail at the following e-mail address:  <a href="mailto:ceit@wbsedcl.in">ceit@wbsedcl.in</a> , <a href="mailto:itcell@wbsedcl.in">itcell@wbsedcl.in</a>  Requests for clarification should be received by the Employer no later than: <b>As per Key dates of NIT/RFB.</b>
<b>ITB 6.5</b>	Pre-Bid meeting shall take place at the following date, time and place: <b>Date: 27.03.2024</b> <b>Time: 12:00 Hrs. (IST).</b> <b>Place: Chief Engineer, IT</b> WBSSEDCL <b>Vidyut Bhawan, 3<sup>rd</sup> Floor, D-Block,</b> <b>Block-DJ, Sector-II, Bidhannagar, Kolkata-700091</b> <b>Tel (O) : 033-2319 7445</b>  <b>Website: <a href="http://www.wbsedcl.in">www.wbsedcl.in</a>, Email: <a href="mailto:ceit@wbsedcl.in">ceit@wbsedcl.in</a>, <a href="mailto:itcell@wbsedcl.in">itcell@wbsedcl.in</a></b>
<b>ITB 7.1</b>	The addendum/corrigendum/ amendment will appear on the e-procurement system specified in ITB 6.1 and email notification is also automatically sent through the system to those bidders who have started working on this procurement.
	<b>C. Preparation of Bids</b>
<b>ITB 10.2.8</b>	The Bidder shall submit the following additional documents in Technical Part of its Bid: (i) Integrity Pact, prepared using the relevant form furnished in Section 4 - Bidding Forms - Technical Part of the Bid.

	<p>(ii) Self-certified copy of the document to establish legal status of the firm viz. Certificate of Incorporation issued under The Companies Act / The Limited Liability Partnership Act / Partnership deed etc. as applicable;</p> <p>(iii) Self-certified copy of PAN;</p> <p>(iv) Self-certified copy of GST Registration;</p> <p>(v) Bank Guarantee (BG) for Bid security</p> <p>(vi) Power of Attorney</p>
<b>ITB 10.3.3</b>	<del>The Bidder shall submit the following additional documents in its Financial Part of its Bid.</del> <b>Deleted.</b>
<b>ITB 11</b>	<b>Note for Bidders:</b> Bidders have to submit the bids on the e-procurement portal along with the relevant required documents. For this purpose, the bidders shall fill up online, the forms that are available for online filling on the e-portal. The rest of the forms shall be download by the bidders and filled up. The filled-up pages shall then be scanned and uploaded on the e-procurement portal along with the scanned copies of the supporting documents. The bid shall be digitally signed.
<b>ITB 11.3</b>	<p><b>The bidders are required to submit hard copy of the documents listed below in original along with the Technical part of their Bid within 2 working days after the last date of the bid submission.</b></p> <p>i) Integrity Pact, prepared using the relevant form furnished in Section 4 - Bidding Forms - Technical Part of the Bid.</p> <p>ii) Self-certified copy of the document to establish legal status of the firm viz. Certificate of Incorporation issued under The Companies Act / The Limited Liability Partnership Act / Partnership deed etc. as applicable</p> <p>iii) Self-certified copy of PAN.</p> <p>iv) Self-certified copy of GST Registration.</p> <p>v) Bank Guarantee (BG) for Bid security <b>(Last Date: 14.05.2024 13:00 Hrs.)</b></p> <p>vi) Power of Attorney.</p> <p>For submission of original documents, the Employer's address is:  <b>Chief Engineer, IT</b>  <b>WBSEDCL</b>  <b>Vidyut Bhawan, 3<sup>rd</sup> Floor, D-Block,</b>  <b>Block-DJ, Sector-II, Bidhannagar, Kolkata-700091</b>  <b>Tel (O) : 033-2359 7445</b>  <b>Website: <a href="http://www.wbsedcl.in">www.wbsedcl.in</a>, Email: <a href="mailto:ceit@wbsedcl.in">ceit@wbsedcl.in</a>, <a href="mailto:itcell@wbsedcl.in">itcell@wbsedcl.in</a></b></p>
<b>ITB 13.1</b>	<b>Not Applicable</b>



<b>ITB 13.5.1(i), ITB 13.5.2 (i)</b>	Final Destination (Site/ Project Site) is: WBSSEDCL DC and DRC sites for material dispatch and delivery shall be notified to the successful Bidder by WBSSEDCL prior to award of Contract.
<b>ITB 13.6</b>	The prices quoted by the Bidder shall be subject to adjustment during the performance of the Contract.  The adjustment of contract price, if provided, will be done in accordance with Appendix to Contract Form.
<b>ITB 13.11</b>	GST applicable in India, on the Plant and Installation Services provided/supplied by the Contractor to the Employer under the Contract shall be paid/ reimbursed by Employer against requisite documents, at actuals.
<b>ITB 17.1</b>	<b>The Bid shall remain valid until i.e. upto and including 180 days reckoned from the deadline for Submission of Bids specified in ITB 21.1, as may be extended by the Employer from time to time in accordance therewith.</b>
<b>ITB 18.1</b>	A Bid Security <i>shall be</i> required. The amount of the Bid Security shall be as specified in <b>Table (Key Dates)</b> .
<b>ITB 18.2 (c)</b>	Other forms of acceptable Bid securities:  ...None...
<b>ITB 18.8</b>	If the Bidder performs any of the actions prescribed in ITB 18.8 (a) or (b), the Employer will declare the Bidder ineligible to be awarded a contract by the Employer for a period of <b>01 (One)</b> year.

<b>ITB 19.3</b>	The written confirmation of authorization to sign on behalf of the Bidder shall consist of: <i>Legally valid Power of Attorney demonstrating the authority of the signatory to sign the Bid.</i>
<b>D. Submission of Bids</b>	
<b>ITB 21.1</b>	<p>The Deadline for Submission of Bids by uploading on e- Procurement system specified in <b>ITB 6.1 and ITB 11</b> is:</p> <p><b>Date: 14.05.2024</b></p> <p><b>Time: (IST). 13:00 Hrs.</b></p> <p>The Deadline for Submission of documents in hard copy as specified in <b>ITB 11.3</b> is:</p> <p><b>Date: 14.05.2024</b></p> <p><b>Time: (IST). 13:00 Hrs.</b></p>
<b>E. Public Opening of Technical Parts of Bids</b>	
<b>ITB 24.1</b>	<p>The online opening of Technical Part of Bids, shall take place at:</p> <p><b>Office of Chief Engineer, IT</b>  <b>WBSEDCL</b>  <b>Vidyut Bhawan, 3<sup>rd</sup> Floor, D-Block,</b>  <b>Block-DJ, Sector-II, Bidhannagar, Kolkata-700091</b>  <b>Tel (O) : 033-2359 7445</b>  <b>Website: <a href="http://www.wbsedcl.in">www.wbsedcl.in</a>, Email: <a href="mailto:ceit@wbsedcl.in">ceit@wbsedcl.in</a>, <a href="mailto:itcell@wbsedcl.in">itcell@wbsedcl.in</a></b></p> <p><b>Date: 14.05.2024</b></p> <p><b>Time: (IST). 14:00 Hrs.</b></p> <p>In the event of the specified date of bid opening being declared a holiday for the Employer, the bids will be opened at the appointed time and location on the next working day.</p>

<b>F. Evaluation of Bids - General Provisions</b>	
<b>ITB 28.3</b>	The adjustment shall be based on the <b>highest</b> price of the item or component as quoted in other substantially responsive Bids. If the price of the item or component cannot be derived from the price of other substantially responsive Bids, the Employer shall use its best estimate.
<b>I. Evaluation of Financial Part of Bids</b>	
<b>ITB 32.1 (e)</b>	GST, quoted separately as per <b>ITB 13.12</b> , shall be considered for arriving at the evaluated Bid cost/ price and comparison of Bids.
<b>ITB 32.1(f)</b>	<p>The Employer's evaluation of a Bid <b>shall also require</b> the consideration of <b>factors listed herein below</b>. Wherever specified, the adjustments shall be determined using the criteria and methodology mentioned in Section 6.</p> <p>Employer's Requirement:</p> <p>(a) Time for Completion: The Plant and Installation Services specified in Employer's Requirement are required to be supplied / provided within the specified Time for Completion. No credit will be given if provided/ supplied before the specified date or period, and Bids offering supply/ completion after the final date/ specified period shall be treated as nonresponsive;</p> <p>(b) Deviation in payment schedule/ terms and conditions of payment: Bidders shall state their Bid price for the payment schedule outlined in the Conditions of Contract. Bids shall be evaluated on the basis of this base price. If a Bid deviates from the specified payment schedule/ terms and conditions of payment, it shall be treated as non-responsive;</p> <p>(c) Life cycle costs: the projected operating and maintenance costs during the life of the Plant, goods or equipment: <b>NO</b></p> <p>(d) Functional Guarantees of the Facilities -<b>YES</b>: (For Items mentioned in <b>Clause 74 of Part-3 of Employer's requirement</b>)</p> <p><b>(e) Functional Guarantees shall be in consolidated bank guarantee period +90 Days claim period thereafter, amounting 10% of quoted supply cost of the referred materials/equipment excluding GST (Format Attached as Form 23) and shall be covered with the Latent Defect Warranty in the form of additional bank guarantee as per the SBD provision in part -3 Employers requirement clause no. 74.</b></p> <p>(f) Cost of withdrawal of deviations: - <b>Not Acceptable</b> (as per Attachment 6 in Section 4)</p>

**ITB 38.3**

Price negotiations: As per NIT.

ITB 35.1 refers to Class I local supplier which is not applicable as per discussion dated 28.03.23

<b>ITB 35.1</b>	<p><del>Only Class I suppliers are eligible for the bid</del></p> <p><del>'Class I local supplier' means a supplier or service provider, whose goods, services or works offered for procurement, meets the minimum local content as prescribed for 'Class I local supplier'. The local content requirement to categorize a supplier as 'Class I local supplier' is minimum 50%. Deleted</del></p>
<b>ITB 36</b>	<p>Provisions related to Abnormally Low Bids will apply.</p> <p>Bids in the range (-20% to -80% ) of the estimated rate shall furnish an additional Performance Security in the format given in the Annexure (Form-22) which shall be equal to 10% of the tendered amount.</p>
<b>ITB 37</b>	<p>The percentage is 70%</p>
<b>J. Award of Contract</b>	
<b>ITB 44.1</b>	<p>The Performance Security amount is 10% of Contract Price excluding GST.</p> <p>The Additional Performance Security amount is 10% percentage of the level of unbalancing i.e. (actual value of supply part of contract) minus (70% of overall contract price excluding GST). 70% is to be defined as per ITB 37 under BDS.</p> <p>The Standard Form of Performance Security acceptable to the Employer shall be as specified in <b>Section 8</b>. Contract Forms.</p>



**Annexure I (BDS)****Bidder Help Manual for E-Bidding**

Guideline for e-Tendering: Instructions/Guidelines for electronic submission of the tenders have been mentioned below for assisting the bidders to participate in e-Tendering.

Registration of bidder: Any bidder willing to take part in the process of e-Tendering will have to be enrolled & registered with the e-Procurement system, through logging on to <https://wbtenders.gov.in>. Bidder has to log into the portal giving user id / password chosen during enrollment.

Digital Signature certificate (DSC): Each bidder is required to obtain a class-II or Class-III Digital Signature Certificate (DSC) for submission of tenders. DSC is given as a USB e-Token. After obtaining the Class-II or Class-III Digital Signature Certificate (DSC) from approved Certifying Authority they are required to register the fact of processing the Digital Signature Certificates through the registration system available in the website. DSC once mapped to an account cannot be remapped to any other account. It can only be Inactivated. The e-token that is registered should be used by the bidder and should not be misused by others.

Downloading of Bid: The bidder can search and download NIT & Tender Documents electronically from the <https://wbtenders.gov.in> using the Digital Signature Certificate. This is the only mode of collection of Tender Documents

Submission of Bid: Bids shall be submitted as under:

1. Tenders are to be submitted online through the website <https://wbtenders.gov.in> only and no other mode of submission of bid will be accepted. All the documents uploaded by the Tender Inviting Authority form an integral part of the contract. Tenderers are required to upload all the tender documents along with the other documents, as asked for, in the tender, through the above website within the stipulated date and time as given in the Tender. Tenders are to be submitted in two folders - one is Technical Proposal and the other is Financial Proposal. The tenderer shall carefully go through the documents and prepare the required documents and upload the scanned documents in Portable Document Format (PDF) to the portal in the designated locations of Technical Bid.
2. The bidder needs to download the Forms / Annexure, fill up the particulars in the designated Cell and upload the same in the designated location of Technical Bid
3. The documents uploaded shall be virus scanned and digitally signed using the Digital Signature Certificate (DSC). Tenderers should take note of all the addendum/corrigendum related to the tender and upload the latest documents as part of the tender

4. Technical Proposal:

The Technical Proposal shall contain scanned copies and/or declarations in the following standardized formats in three covers (folders).

Folder-1 : NIT& any Corrigendum & Scanned copy of Bank Guarantee (BG) towards Bid Security as prescribed in NIT along with under takings and also original Bid proposal are to be submitted in details in folder-1.

Folder-2: Credentials and documents must be filled & submitted in folder-2

5. Financial Proposal:

The financial proposal should contain the following documents in one cover (folder) named as Financial Proposal Folder. A pro-forma is enclosed as Annexure-VI for reference; please do not quote in the pro-forma.

6. Bill of Quantities(BOQ):

The bidder is to quote the Price online through computer in the space marked for quoting Price in the BOQ for each respective zone

7. At the time of freezing the bid, the eProcurement system will give a successful bid

updating message after uploading all the bid documents submitted and then a bid summary will be shown with the bid no, date & time of submission of the bid with all other relevant details. The documents submitted by the bidders will be digitally signed using the e-token of the bidder and then submitted.

8. After the bid submission, the bid summary has to be printed and kept as an acknowledgement as a token of the submission of the bid. The bid summary will act as a proof of bid submission for a tender floated and will also act as an entry point to participate in the bid opening event.

9. The bidders are requested to submit the bids through online eProcurement system to the TIA well before the bid submission end date and time (as per Server System Clock).

#### ASSISTANCE TO BIDDERS:

- There is no limit on the size of the file uploaded at the server end. However, the upload is decided on the Memory available at the Client System as well as the Network bandwidth available at the client side at that point of time. In order to reduce the file size, bidders are suggested to scan the documents in 75-100 DPI so that the clarity is maintained and also the size of file also gets reduced. This will help in quick uploading even at very low bandwidth speeds.
- Successful bid submission from the system means, the bids as uploaded by the bidder is received and stored in the system. System does not certify for its correctness.
- The bidder should see that the bid documents submitted should be free from virus and if the documents could not be opened, due to virus, during tender opening, the bid is liable to be rejected.
- The time that is displayed from the server clock at the top of the tender Portal, will be valid for all actions of requesting bid submission, bid opening etc., in the e-Procurement portal. The Time followed in this portal is as per Indian Standard Time (IST) which is GMT+5:30. The bidders should adhere to this time during bid submission.
- Bidders are requested to visit e-procurement portal, The details and relevant links are available in the Bidders Manual Kit on the right pane of website which is furnished here:-

SL.NO Particulars	Downloads
1. Notice to Bidders for e-Bid Submission	<a href="#"><u>Notice_to_bidders_v906.pdf</u></a>
2. Registration of Bidders	<a href="#"><u>Bidder_Registration_Manual_Updated_v906.pdf</u></a>
3. Bidders Manual for Tender Cum Auction	<a href="#"><u>Instructions_to_Bidders_for_Tender_Cum_Auction_18_06_2021.pdf</u></a>
4. Uploading of My Documents	<a href="#"><u>MyDocument_Updated_v906.pdf</u></a>
5. Online e-Bid Submission	<a href="#"><u>Four_cover_bid_submission_new_v906.pdf</u></a>
	<a href="#"><u>Two_cover_bid_submission_new_v906.pdf</u></a>
	<a href="#"><u>Single_Cover_bid_submission_New_v906.pdf</u></a>
	<a href="#"><u>Three_Cover_Bid_Submission_New_v906.pdf</u></a>
6. Online Bid Withdrawal	<a href="#"><u>bid_withdrawal_updated_v906.pdf</u></a>
7. Online Bid Re-submission	<a href="#"><u>Bid_Resubmission_Updated_v906.pdf</u></a>
8. Clarifications (Tender Status, My Archive...)	<a href="#"><u>Enquiry_Updated_v906.pdf</u></a>
9. BOQ Preparation Guidelines	<a href="#"><u>ItemRate_BOQ_Updated_v906.pdf</u></a>



---

**Section - 4 : Bidding Forms - Technical Part of the Bid**



**Form 1****Letter of Bid – Technical Part**

**Date of this Bid submission:** [insert date (as day, month and year) of Bid submission]

**NIT/RFB No.:** [insert number of Bidding process]

**Title of Procurement/ Contract:** [Insert here the title]

**To:**

**Chief Engineer , IT**

**WBSEDCL**

**Vidyut Bhawan, 3<sup>rd</sup> Floor, Block-DJ, Sector-II,**

**Bidhannagar, Kolkata-700091**

**Tel (O) : 033-2359 7445**

*Website: [www.wbsedcl.in](http://www.wbsedcl.in), Email: [ceit@wbsedcl.in](mailto:ceit@wbsedcl.in), [itcell@wbsedcl.in](mailto:itcell@wbsedcl.in)*

1.0 We, the undersigned Bidder, hereby submit our Bid, in two parts, namely:

- (a) the Technical Part, and
- (b) the Financial Part.

2.0 In submitting our Bid we make the following declarations:

- (a) **No reservations:** We have examined and have no reservations to the bidding document (ITB5), including addenda issued in accordance with Instructions to Bidders (ITB 7);
- (b) **Eligibility:** We meet the eligibility requirements and have no conflict of interest in accordance with ITB 3 and Section 3;
- (c) **Bid/Proposal-Securing Declaration:** We have not been suspended nor declared ineligible by the Purchaser based on execution of a Bid Securing Declaration by the Purchaser in accordance with ITB 10.2.2;
- (d) **Conformity:** We offer to supply in conformity with the bidding document and in accordance with the Delivery Schedules specified in the Schedule of Requirements the all the Goods and Related Services as per the scope mentioned in Part 2, Section 6.;
- (e) **Bid Validity Period:** Our Bid shall be valid for the period specified in BDS 17.1 (as amended if applicable) from the date fixed for the deadline for submission of Bids (specified in BDS 21.1 (as amended if applicable), and it shall remain binding upon us and may be accepted at any time before the expiration of that period;
- (f) **Performance Security:** If our Bid is accepted, we commit to obtain a performance security in accordance with the bidding document;
- (g) **One Bid per Bidder:** We are not submitting any other Bid(s) as an individual Bidder, and meet the requirements of ITB 4.2;
- (h) **Suspension:** We, along with any of our subcontractors, suppliers, consultants, manufacturers, or service providers for any part of the contract, are not subject to, and not controlled by any entity or individual that is subject to, a temporary suspension or a blacklist as specified in Section 2, Clause 1.3. Further, we are not ineligible under the Purchaser's country laws or official regulations or pursuant to a decision of the United

## Nations Security Council;

- (i) **Binding Contract:** We understand that this Bid, together with your written acceptance thereof included in your Letter of Acceptance, shall constitute a binding contract between us, until a formal contract is prepared and executed;
- (j) **Not Bound to Accept:** We understand that you are not bound to accept the lowest evaluated cost/price Bid, the Most Advantageous Bid or any other Bid that you may receive;
- (k) **Fraud and Corruption:** We hereby certify that we have taken steps to ensure that no person acting for us, or on our behalf, engages in any type of Fraud and Corruption;
- (l) *(applicable only if the bidder is a Joint Venture as per Section 2 of RFB/ bidding document)* We have bid as a Joint Venture as per Section 2 of RFB/ bidding document) and in accordance with Clause 1.2 of Section 2 we declare and confirm that all partners of the joint venture shall be liable jointly and severally for the execution of the contract in accordance with the contract terms;
- (m) We submit appended herewith, as integral part of the Technical Part of our bid, the details/ documents as listed in the table below in the Forms duly filled, as prescribed, along with supporting documentary evidence as required/ specified. We understand and confirm that we would be solely responsible for any errors or omissions in our Bid and your decision in regard to sufficiency and/ or adequacy of the details/ documents comprising our Bid for determining its completeness shall be final and binding.

Sr.	Document	Status (Submitted/ Not Submitted/ Not Applicable)
1.	This Letter of Bid as per format prescribed in <b>Form 1</b> given in Section 4 of RFB/ bidding document	
2	Bidder Information as per the format prescribed in <b>Form 2</b> given in Section 4 of RFB/ bidding document	
3	Bid Security or Bid Securing Declaration , as may be specified in ITB 18 Section 3 of RFB/ bidding document, in the form of specified in ITB . Bid Securing Declaration in format prescribed in <b>Form 3A</b> given in Section 4 and Bid Security in the form of Bank Guarantee in format prescribed in <b>Form 3B</b> given in Section 4 of RFB/ bidding document.	
4.	Power of Attorney by Lead Joint Venture Member/ Sole Bidder authorizing an Individual Designated Representative for the Joint Venture Bidder/ Sole Bidder as per the format prescribed in <b>Form 4</b> given in Section 4 of RFB/ bidding	

Sr.	Document	Status (Submitted/ Not Submitted/ Not Applicable)
	document	
5.	Declaration of conformance of the Bidder and the Facilities offered, to the specified eligibility requirement specified in Section 2 and Section 3, as per the format prescribed in <b>Form 5</b> given in Section 4 of RFB/ bidding document	
6.	Local Content Certificate for Class I Local Supplier, as specified in Clause 1.5 of Section 2 of RFB/ bidding document, Affidavit of Self certification as per the format prescribed in <b>Form 6</b> given in Section 4 of RFB/ bidding document or by certificate ( <b>format not specified</b> ) of Statutory Auditor, as may be applicable	
7	Power of Attorney by each member/ partner of the Joint Venture in favour of Lead member/ partner as per format prescribed in <b>Form 7</b> given in Section 4 of RFB/ bidding document ( <i>applicable only for Joint Venture Bidder</i> )	
8 A	Joint Deed of Undertaking (JDU) signed by each member/ partner of the Joint Venture, as per format prescribed in <b>Form 8</b> given in Section 4 of RFB/ bidding document ( <i>applicable only for Joint Venture Bidder</i> )	
8 B	Joint Venture Agreement entered amongst all the partners/ members of the Joint Venture in their own format but without violating any of the requirements of the bidding documents and necessarily including the confirmation as specified in Clause 1.2 of Section 2 of RFB/ bidding document ( <i>applicable only for Joint Venture Bidder</i> )	
9	Details/ Data and documentary evidence in support of meeting the Qualification Requirement specified in Section 2 of RFB/ bidding document, as per the format prescribed in <b>Form 9</b> given in Section 4 of RFB/ bidding document	
10.	The details of all major items of Plant and Installation Services proposed to be subcontracted in case of award, indicating name and nationality of the proposed subcontractor/sub-vendor for each item, as per the format prescribed in <b>Form 10</b> given in Section 4 of RFB/ bidding document.  as per the format prescribed in Form 1 given in Section 4	
11.	Form of Undertaking on Compliance of Terms & Conditions of the RFB/ bidding document including Scope of Work and other related requirements, as per the format prescribed in <b>Form 11</b> given in Section 4 of RFB/ bidding document, <i>subject to Sl No. 12 below of this table</i>	

Sr.	Document	Status (Submitted/ Not Submitted/ Not Applicable)
12	Statement of Deviation from the requirements specified in the RFB/ bidding documents including Conditions of Contract, Employer's Requirement/ Specification and Drawings etc, including, inter alia, the cost of withdrawal thereof, as per the format prescribed in <b>Form 12</b> given in Section 4 of RFB/ bidding document	
13	Work Completion Schedule, as per the format prescribed in <b>Form 13</b> given in Section 4 of RFB/ bidding document	
14	Guarantee Declaration, as per the format prescribed in <b>Form 14</b> given in Section 4 of RFB/ bidding document	
15	Information regarding ex-employees of Employer in our firm, as per the format prescribed in <b>Form 15</b> given in Section 4 of RFB/ bidding document	
16	Filled up information regarding Price Adjustment Data, as per the format prescribed in <b>Form 16</b> given in Section 4 of RFB/ bidding document	
17	Option for Interest bearing Initial Advance payment and Information for E-payment, PF details and declaration regarding Micro/Small & Medium Enterprises, as per the format prescribed in <b>Form 17</b> given in Section 4 of RFB/ bidding document	
18	Declaration for tax exemptions, reductions, allowances or benefits, as per the format prescribed in <b>Form 18</b> given in Section 4 of RFB/ bidding document	
19	Bank Guarantee verification checklist, as per the format prescribed in <b>Form 19</b> given in Section 4 of RFB/ bidding document	
20	Additional Information, if any, as per the format prescribed in <b>Form 20</b> given in Section 4 of RFB/ bidding document	
21	Integrity Pact, duly signed on each page by the person signing the bid, as per the format prescribed in <b>Form 21</b> given in Section 4 of RFB/ bidding document	
22	<b>Form 23 &amp; Form 24</b> are to be agreed & signed by successful bidder	
23	<b>Form 25</b> is to be submitted for each OEM as mentioned in the submitted technical bid by the bidder.	

- (n) We are also submitting herewith the Financial Part of our Bid, online separately, as per the prescribed Forms given in Section 4 of RFB/ bidding document, complete in all respects in electronic form only, as per the requirements of RFB/ bidding document. We

confirm that the same does not contain any deviation, reservation or omission, failing which it is liable to be rejected.

**(o) Contact Person**

Details of the contact person representing us supported by the Power of Attorney, as prescribed, are furnished as under:

Name: .....  
Designation: .....  
Company: .....  
Address: .....  
Mobile: .....  
Phone: .....  
Fax: .....  
Email: .....

Dated the ..... *[Insert date of the month]* day of..... *[Insert month, year]*  
at..... *[Insert place]*.

\_\_\_\_\_  
Signature {(of Bidder’s authorized Bid Signatory (ies))<sup>#</sup> {In full and initials}}:

Full name: {insert full name of authorized Bid Signatory }  
Title: {insert title/position of authorized Bid Signatory }  
Name of Bidder (Sole Bidder’s name or Consortium/ JV’s name, if applicable):  
Capacity: {insert the person’s capacity to sign for the Bidder }  
Address: {insert the authorized Bid Signatory’s address }  
Phone/fax: {insert the authorized Bid Signatory’s phone and fax number, if applicable}  
Email: {insert the authorized Bid Signatory’s email address }\_\_\_\_\_

<sup>#</sup>{*For a joint venture, either all members shall sign or only the authorized signatory as per ITB 19.4, in either case the power of attorney of the authorized bid signatory (signatories) must be attached*}

**Form 2****(Appendix to Technical Part of the Bid)****Format for Bidder Information Sheet**

*[The Bidder shall fill in this Form in accordance with the instructions indicated below. No alterations to its format shall be permitted and no substitutions shall be accepted.]*

NIT/RFB No.: *[insert details]*Contract Title: *[insert details]*

Page \_\_\_\_\_ of \_\_\_\_\_ pages

1. Bidder's Legal Name
2. Legal Status of the Bidder
3. Bidder's Country of Registration:
4. Bidder's Year of Registration:
5. Bidder's Legal Address in Country of Registration:
6. Bidder's Authorized Representative Information Name: Address: Telephone/Fax numbers: Email Address:
7. Attached are copies of original documents of <i>[check the box(es) of the attached original documents]</i> <ul style="list-style-type: none"> <li>○ Self certified copy of the document to establish legal status of the firm viz. Certificate of Incorporation issued under the Companies Act / The Limited Liability Partnership Act / Partnership deed etc. as applicable;</li> <li>○ Self certified copy of PAN</li> <li>○ Self certified copy of GST Registration;</li> <li>○ Self certified copy in support of MSME, if applicable</li> <li>○ Organizational chart including a list of Board of Directors/ Key Management Personnels..</li> </ul>



Note : In case of JV/ Consortium, the afore details/ documents are to be furnished for each of the JV/ Consortium Members
---

Dated the ..... [Insert date of the month] day of..... [Insert month, year]  
at..... [Insert place].

---

Signature {(of Bidder's authorized Bid Signatory (ies))}# {In full and initials}:

Full name: {insert full name of authorized Bid Signatory }

Title: {insert title/position of authorized Bid Signatory }

Name of Bidder (Sole Bidder's name or Consortium/ JV's name, if applicable):

Capacity: {insert the person's capacity to sign for the Bidder }

Address: {insert the authorized Bid Signatory's address }

Phone/fax: {insert the authorized Bid Signatory's phone and fax number, if applicable }

Email: {insert the authorized Bid Signatory's email address }\_\_\_\_\_

#{For a joint venture, either all members shall sign or only the authorized signatory as per ITB 19.4, in either case the power of attorney of the authorized bid signatory (signatories) must be attached}

**Form 3A****(Appendix to Technical Part of the Bid)****Format of Bid Securing Declaration  
(if applicable)****BID SECURING DECLARATION**

Whereas, I/We (name of Bidder) ----- have submitted Bid in response to Request For Bid (RFB) no: -----  
dated : -----

I/We hereby submit following declaration in lieu of Bid Security/ Earnest Money Deposit:

1. If after the opening of Proposal, I/We withdraw and/or modify my/our Proposal during its period of validity (including extended validity) as specified in the RFB document,  
Or
2. If, after the issue of Notification of Award of the Contract, I/We fail to sign the Contract, or to submit Contract Performance Guarantee before the deadline specified in the RFB document,  
Or
3. If, in case of I/ we fail to ensure that the Contract becomes Effective as specified in the RFB document.

I/we shall be suspended from and shall not be eligible to participate for a period of [... to be filled in by the Utility as per ITB 18.8....] year from date of issue of the suspension order, inthe bidding against any of the Notice Inviting Tenders/ Invitation For Bids/ Request for Proposal/ Bid etc. issued by WBSSEDCL during that period.

Dated the ..... [Insert date of the month] day of..... [Insert month, year]  
at..... [Insert place].

\_\_\_\_\_  
Signature {(of Bidder's authorized Bid Signatory (ies))<sup>#</sup> {In full and initials}}:

Full name: {insert full name of authorized Bid Signatory }

Title: {insert title/position of authorized Bid Signatory }

Name of Bidder (Sole Bidder's name or Consortium/ JV's name, if applicable):

Capacity: {insert the person's capacity to sign for the Bidder }

Address: {insert the authorized Bid Signatory's address }

Phone/fax: {insert the authorized Bid Signatory's phone and fax number, if applicable }

Email: {insert the authorized Bid Signatory's email address }\_\_\_\_\_

*# {For a joint venture, either all members shall sign or only the authorized signatory as per ITB 19.4, in either case the power of attorney of the authorized bid signatory (signatories) must be attached}*

**Form 3B****(Appendix to Technical Part of the Bid)****Format of Bank Guarantee for Bid Security**

*{To be on non-judicial stamp paper of Rupees One Hundred Only (INR 100/-) or appropriate value as per Stamp Act relevant to place of execution, duly signed on each page.}*

Reference No. ....  
.....

Bank Guarantee No. ....

Dated:

To:

**Chief Engineer, IT  
WBSEDCL  
Vidyut Bhawan, 3<sup>rd</sup> Floor,  
Block-DJ, Sector-II,  
Bidhannagar, Kolkata-700091**

Dear Sir/ Madam,

WHEREAS..... [Insert name of the Sole Bidder] / [insert name of the Lead Joint Venture Member followed by the words “representing Joint Venture of [insert names of all the members of Joint Venture]”] with address ..... [Insert address of Sole Bidder /Lead Joint Venture Member] having its registered office at ..... [Insert address of the Sole Bidder /Lead Joint Venture Member] (Hereinafter, the “Bidder”) wishes to participate in Tender No. [Tender Details] (the “RFB”) issued by WBSEDCL for [Contract title].

And WHEREAS a Bank Guarantee for [Amount] valid till [Date] is required to be submitted by the Bidder along with the RFB.

We, .....[Insert name of the Bank and address of the Branch giving the Bank Guarantee] having our registered office at .....[Insert address of the registered office of the Bank] hereby give this Bank Guarantee No. .... [Insert Bank Guarantee number] dated .....[Insert the date of the Bank Guarantee], and hereby agree unequivocally and unconditionally to pay immediately on demand in writing from the Utility any officer authorized by it in this behalf any amount not exceeding [Amount] to the said Utility on behalf of the Bidder.

We ..... [Insert name of the Bank] also agree that withdrawal of the Bid or part thereof by the Bidder within its validity or not signing the Contract Agreement or non-submission of Performance Security by the Bidder within the stipulated time of the Letter of Award to the Bidder or any violation to the relevant terms stipulated in the RFB would constitute a default on the part of the Bidder and that this Bank Guarantee is liable to be invoked and encashed within its validity

by the Utility in case of any occurrence of a default on the part of the Bidder and that the amount is liable to be forfeited by the Utility.

This Guarantee shall be valid and binding on this Bank up to and inclusive of .....  
 [Insert the date of validity of the Bank] and shall not be terminable by notice or by Guarantor for the reason of change in the constitution of the Bank or the firm of the Bidder or by any reason whatsoever and our liability hereunder shall not be impaired or discharged by any extension of time or variations or alternations made, given, conceded with or without our knowledge or consent by or between the Bidder and the Utility.

NOTWITHSTANDING anything contained hereinbefore, our liability under this guarantee is restricted to [Amount]. Our Guarantee shall remain in force till [Date]. Unless demands or claims under this Bank Guarantee are made to us in writing on or before [Date], all rights of the Beneficiary under this Bank Guarantee shall be forfeited, and we shall be released and discharged from all liabilities there under.

<i>[Insert the address of the Bank with complete postal branch code, telephone and fax numbers, and official round seal of the Bank]</i>	<i>[Insert signature of the Bank's Authorized Signatory]</i>
<i>Attested</i>	
..... [Signature] (Notary Public)	
Place: .....	Date: .....

**INSTRUCTIONS FOR SUBMITTING BANK GUARANTEE**

1. Bank Guarantee to be executed on non-judicial stamp paper of appropriate value as per Stamp Act relevant to place of execution.
2. The Bank Guarantee by Bidder shall be given from any Scheduled Commercial Bank.
3. The full address along with the Telex/Fax No. and e-mail address of the issuing bank to be mentioned.

**Form 4**

**(Appendix to Technical Part of the Bid)**

**Format of Power of Attorney of designated Bid Signatory by sole bidder/ lead joint venture member**

*[To be on non-judicial stamp paper of Rupees One Hundred Only (INR 100/-) or appropriate value as per Stamp Act relevant to place of execution.]*

Know all men by these presents, we ..... *[Insert name and address of the registered office of the Lead Consortium Member of the Bidding Consortium/ Sole Bidder]* do hereby constitute, appoint, nominate and authorize Mr./Ms. .... *[Insert name and residential address]*, who is presently employed with us and holding the position of..... as our true and lawful attorney, to do in our name and on our behalf, all such acts, deeds and things necessary in connection with or incidental to submission of our Bid in response to RFB/ Tender No. [RFB/ Tender Details] for [Contract title] (the “Project”) issued by WBSEDCL, including signing and submission of the Bid and all other documents related to the Bid, including but not limited to undertakings, letters, certificates, acceptances, clarifications, guarantees or any other document which Utility may require us to submit. The aforesaid attorney is further authorized for making representations to Utility, and providing information / responses to Utility, representing us in all matters before Utility, and generally dealing with Utility in all matters in connection with our Bid till the completion of the bidding process as per the terms of the RFB.

We hereby agree to ratify all acts, deeds and things done by our said attorney pursuant to this Power of Attorney and that all acts, deeds and things done by our aforesaid attorney shall be binding on us and shall always be deemed to have been done by us.

All the terms used herein but not defined shall have the meaning ascribed to such terms under the RFB.

**Signed by the within named ..... *[Insert the name of the executant company]* through the hand of Mr./ Mrs..... duly authorized by the Board/ Owner to issue such Power of Attorney dated this ..... day of .....**

**Accepted**

..... (Signature of Attorney)  
[Insert Name, designation and address of the Attorney]

**Attested**

.....  
(Signature of the executant)  
(Name, designation and address of the executant)

.....  
Signature and stamp of Notary of the place of execution

**Common seal of ..... has been affixed in my/our presence pursuant to Board of Director’s Resolution dated..../ Owner**

**1. WITNESS 1. ....(Signature)**  
**Name .....**  
**Designation.....**

**2. WITNESS 2. ....(Signature)**  
**Name .....**  
**Designation .....\_**

---

**Notes:**

- a. *The mode of execution of the power of attorney should be in accordance with the procedure, if any, laid down by the applicable law and the charter documents of the executant(s).*
  - b. *In the event, power of attorney has been executed outside India, the same needs to be duly notarized by a notary public of the jurisdiction where it is executed.*
  - c. *Also, wherever required, the executant(s) should submit for verification the extract of the charter documents and documents such as a Board resolution / power of attorney, in favor of the person executing this power of attorney for delegation of power hereunder on behalf of the executant(s).*
-

**Form 5**

**(Appendix to Technical Part of the Bid)**

**Format of Declaration of conformance of the Bidder and the Facilities offered, to the specified eligibility requirement**

NIT/RFB No.: *[insert details]*

Contract Title: *[insert details]*

To:

**Chief Engineer, IT  
WBSEDCL  
Vidyut Bhawan, 3<sup>rd</sup> Floor,  
Block-DJ, Sector-II,  
Bidhannagar, Kolkata-700091**

Bidder’s Name and Address:  
*{In case of JV bidder, mention name  
and address of all the Joint Venture members }*

We hereby certify that Plant and Installation Services offered to be supplied by us fully comply with all the eligibility and other requirements specified in Section 2 and Section 3 of RFB/ bidding documents.

We hereby certify that our firm is legally established in India and we fully comply with the eligibility and other requirements specified in Section 2 and Section 3 of RFB/ bidding documents,

Dated the ..... *[Insert date of the month]* day of..... *[Insert month, year]* at..... *[Insert place]*.

\_\_\_\_\_  
Signature {(of Bidder’s authorized Bid Signatory (ies))<sup>#</sup> {In full and initials}}:

Full name: {insert full name of authorized Bid Signatory}  
Title: {insert title/position of authorized Bid Signatory}  
Name of Bidder (Sole Bidder’s name or Consortium/ JV’s name, if applicable):  
Capacity: {insert the person’s capacity to sign for the Bidder}  
Address: {insert the authorized Bid Signatory’s address}  
Phone/fax: {insert the authorized Bid Signatory’s phone and fax number, if applicable}  
Email: {insert the authorized Bid Signatory’s email address}\_\_\_\_\_

<sup>#</sup>*{For a joint venture, either all members shall sign or only the authorized signatory as per ITB 19.4, in either case the power of attorney of the authorized bid signatory (signatories) must be attached}*



**Form 6**

(Appendix to Technical Part of the Bid)

**Format for Affidavit of Self certification regarding Local Content in line with PPP-MII order and #MoP Order/DoT order***[if applicable, to be provided on a non-judicial stamp paper of Rs. 100/- ]*NIT/RFB No.: *[insert details]*Contract Title: *[insert details]*

**To:**  
**Chief Engineer, IT**  
**WBSEDCL**  
**Vidyut Bhawan, 3<sup>rd</sup> Floor,**  
**Block-DJ, Sector-II,**  
**Bidhannagar, Kolkata-700091**

Bidder's Name and Address:

*{In case of JV bidder, mention name  
and address of all the Joint Venture members}*

I We \_\_\_\_\_S/o, D/o, W/o, \_\_\_\_\_Resident  
of \_\_\_\_\_, on behalf of the  
firm(s) named above, hereby solemnly affirm and declare as under:

That we will agree to abide by the terms and conditions of the Public Procurement Order, 2017 of Government of India issued vide Notification No:P- 45021/2/2017 -BE-II dated 15/06/2017, its revision dated **04/06/2020** (hereinafter **PPP-MII order**),

That the information furnished hereinafter is correct to the best of my knowledge and belief and I undertake to produce relevant records before the procuring entity/POWERGRID or any other Government authority for the purpose of assessing the local content of plant/goods/material/ services/works supplied by me for .....*[insert the reference of RFB and Contract title]*.

That the local content for all inputs which constitute the said plant/ goods/material/ services/works has been verified by me and I am responsible for the correctness of the claims made therein.

**That the ‘Local Content ‘as defined in the PPP-MII order and #MoP order /DoT order in the plant/goods/material/ services/works supplied by me for ..... (contract title) is ..... percent (%).**

That in the event of the local content of the plant/goods/material/ services/works mentioned herein is found to be incorrect and not meeting the prescribed Local Content criteria, based on the assessment of procuring agency (ies)/ WBSMEDCL /Government Authorities for the purpose of assessing the local content, action shall be taken against me in line with the PPP-MII order, **MoP order** and provisions of the Integrity pact/ Bidding Documents.

I agree to maintain the following information in the Company's record for a period of 8 years and shall make this available for verification to any statutory authority.

- i Name and details of the Local Supplier  
(Registered Office, Manufacturing unit location, nature of legal entity)
- ii. Date on which this certificate is issued
- iii. Plant/goods/services/works for which the certificate is produced
- iv. Procuring entity to whom the certificate is furnished
- v. Percentage of local content claimed and whether it meets the Local Content prescribed for ‘**Class –I local supplier**’/‘**Class-II Local supplier** (*choose as applicable*)
- vi. Name and contact details of the unit of the Local Supplier (s)
- vii. Sale Price of the product
- viii Ex-Factory Price of the product
- ix. Freight, insurance and handling
- x. Total Bill of Material

- xi List and total cost value of input used to manufacture the Goods/to provide services/in construction of works
- xii. List and total cost of input which are domestically sourced. Value addition certificates from suppliers if the input is not in-house to be attached
- xiii. List and cost of inputs which are imported, directly or indirectly

Dated the ..... *[Insert date of the month]* day of..... *[Insert month, year]*  
at..... *[Insert place]*.

\_\_\_\_\_  
Signature {(of Bidder's authorized Bid Signatory (ies))<sup>#</sup> {In full and initials}}:

Full name: {insert full name of authorized Bid Signatory }

Title: {insert title/position of authorized Bid Signatory }

Name of Bidder (Sole Bidder's name or Consortium/ JV's name, if applicable):

Capacity: {insert the person's capacity to sign for the Bidder}

Address: {insert the authorized Bid Signatory's address}

Phone/fax: {insert the authorized Bid Signatory's phone and fax number, if applicable}

Email: {insert the authorized Bid Signatory's email address}\_\_\_\_\_

<sup>#</sup>{*For a joint venture, or only the authorized signatory as per ITB 19.4, in either case the power of attorney of the authorized bid signatory (signatories) must be attached*}

***# choose as applicable while preparing bidding documents***

## Form 7

(Appendix to Technical Part of the Bid)

### Format of Power of Attorney by Each Member/ Partner of The Joint Venture in favor of Lead Member/ Partner

KNOW ALL MEN BY THESE PRESENTS THAT WE , the Partners whose details are given hereunder ..... have formed a Joint Venture under the laws of ..... and having our Registered Office(s)/Head Office(s) at ..... (hereinafter called the 'Joint Venture' which expression shall unless repugnant to the context or meaning thereof, include its successors, administrators and assigns) acting through M/s ..... being the Partner in-charge, do hereby constitute, nominate and appoint M/s..... a Company incorporated under the laws of ..... and having its Registered/Head Office at..... as our duly constituted lawful Attorney (hereinafter called "Attorney" or "Authorized Representative" or "Partner In-charge" or "Lead Partner" or "Lead Member" or "Leader") to exercise all or any of the powers for and on behalf of the Joint Venture in regard to Request for Bids (RFB)/ Request for Proposals (RFP) No.....the bids for which have been invited by **The Chief Engineer, IT, WBSEDCL, Vidyut Bhawan, 3<sup>rd</sup> Floor, Block-DJ, Sector-II, Bidhannagar, Kolkata-700091** (hereinafter called the 'Employer') to undertake the following acts :

- i) To submit proposal/ Bid and participate in the aforesaid Bidding, against the RFB/ RFP issued of the Employer, on behalf of the "Joint Venture".
- ii) To negotiate with the Employer the terms and conditions for award of the Contract pursuant to the aforesaid Bid and to sign the Contract with the Employer for and on behalf of the "Joint Venture".
- iii) To do any other act or submit any document related to the above.
- iv) To receive, accept and execute the Contract for and on behalf of the "Joint Venture".

It is clearly understood that the Partner In-charge (Lead Partner/ Lead Member) shall ensure performance of the Contract(s) and if one or more Partner fail to perform their respective portions of the Contract(s), the same shall be deemed to be a default by all the Partners.

It is expressly understood that this Power of Attorney shall remain valid binding and irrevocable till completion of the Defect Liability Period in terms of the Contract.

The Joint Venture hereby agrees and undertakes to ratify and confirm all and whatsoever the said Attorney/Authorized Representatives/Partner in-charge/ Lead Partner/ Lead Member quotes in the bid, negotiates and signs the Contract with the Employer and/or proposes to act or acts on behalf of the Joint Venture by virtue of this Power of Attorney and the same shall bind the Joint Venture as if done by itself.

IN WITNESS THEREOF the Partners Constituting the Joint Venture as aforesaid have executed these presents on this ..... day of..... under the Common Seal(s) of their respective Companies.

for and on behalf of the  
Partners of Joint Venture

.....  
.....  
.....

The Common Seal of the above Partners of the Joint Venture:

The Common Seal has been affixed there unto in the presence of:

WITNESS

- 1. Signature.....  
    Name .....  
    Designation .....  
    Occupation .....
- 2. Signature.....  
    Name .....  
    Designation .....  
    Occupation .....

**Note:**

- 1. For the purpose of executing the power of attorney , the non-judicial stamp papers of appropriate value shall be purchased in the name of Joint Venture.

2. The power of attorney shall be signed on all the pages by the authorized representatives of each of the partners and should invariably be witnessed and notarized.

## Form 8

(Appendix to Technical Part of the Bid)

### Format of Joint Deed of Undertaking by the Joint Venture Partners/ Members

THIS JOINT DEED OF UNDERTAKING executed on this..... day of... ..... Two Thousand and..... by .....a company incorporated under the laws of ..... and having its Registered Office at .....(hereinafter called the "Party No.1" which expression shall include its successors, executors and permitted assigns) and M/s.....a company incorporated under the laws of ..... and having its Registered Office at ..... (hereinafter called the "Party No.2" which expression shall include its successors, executors and permitted assigns ). and M/s.. . . . . a Company incorporated under the laws of ..... and having its Registered Office at ..... (hereinafter called the "Party No.3" which expression shall include its successors, executors and permitted assigns) for the purpose of making a bid and entering into a contract [hereinafter called the "Contract" {in case of award}] against the Request For Bids (RFB)/ Request for Proposal (RFP) No..... for ..... (insert the project name) ..... of Chief Engineer, IT, **WBSEDCL** a Company incorporated under the Companies Act of 1956 having its registered office at **Vidyut Bhawan, 3rd Floor, Block-DJ, Sector-II, Bidhannagar, Kolkata-700091.**

WHEREAS the Party No.1, Party No.2 and Party No.3 have entered into an Agreement dated.....

AND WHEREAS the Employer invited bids as per the above mentioned Package for the design, supply and installation of the Plant as stipulated in the Bidding Documents for ..... (insert name of the project ) .....

AND WHEREAS as per Section 2/ Section 3 of the Bidding Documents, inter-alia stipulates that a Joint Venture, as specified therein, may bid, provided, the Joint Venture and the partners/ members in/ of the Joint Ventures fulfill all the specified requirements of the Bidding Documents and that , in such a case, the Bid shall be signed by all the partners so as to legally bind all the Partners of the Joint Venture, who will be jointly and severally liable to perform the Contract and all obligations hereunder.

AND WHEREAS the bid is being submitted to the Employer vide proposal No.....dated..... by Party No.1 based on this Undertaking between all the parties; under these presents and the bid in accordance with the requirements of Section 2/

Section 3 of the Bidding Documents, has been signed in accordance with the provisions contained therein.

NOW THIS UNDERTAKING WITNESSETH AS UNDER:

In consideration of the above premises and agreements all the parties of this Deed of Undertaking do hereby declare and undertake:

1. In requirement of the award of the Contract by the Employer to the Joint Venture Partners, we, the Parties do hereby undertake that M/s..... the Party No.1, shall act as Lead Partner/ Lead Member/ Authorized Representative/ Partner-in- Charge of the Joint Venture, and further declare and confirm that we the parties to the Joint Venture shall jointly and severally be bound unto the Employer for the successful performance of the Contract and shall be fully responsible for the design, supply and installation of the Plant and for successful performance of the Contract in the event of award and performance of equipment in accordance with the Contract:
2. In case of any breach or default of the said Contract by any of the parties to the Joint Venture, the party(s) do hereby undertake to be fully responsible for the successful performance of the Contract and to carry out all the obligations and responsibilities under the Contract in accordance with the requirements of the Contract.
3. Further, if the Employer suffers any loss or damage on account of any breach in the Contract or any shortfall in the performance of the equipment in meeting the performances guaranteed as per the specification in terms of the Contract, the Party(s) of these presents undertake to promptly make good such loss or damages caused to the Employer, on its demand without any demur. It shall not be necessary or obligatory for the Employer to proceed against Lead Partner to these presents before proceeding against or dealing with the other Party(ies), the Employer can proceed against any of the parties who shall be jointly and severally liable for the performance and all other liabilities/obligations under the Contract to the Employer.
4. The financial liability of the Parties of this Deed of Undertaking to the Employer, with respect to any of the claims arising out of the performance or non-performance of the obligations set forth in this Deed of Undertaking, read in conjunction with the relevant conditions of the Contract shall, however, not be limited in any way so as to restrict or limit the liabilities or obligations of any of the Parties of this Deed of Undertaking.
5. It is expressly understood and agreed between the Parties to this Undertaking that the responsibilities and obligations of each of the Parties shall be as delineated in **Appendix – I** (*to be suitably appended by the Parties along with this Undertaking in its bid*) to this Deed of Undertaking. It is further undertaken by the parties that the above sharing of responsibilities and obligations shall not in any way be a limitation of joint and several responsibilities of the Parties under the Contract.



- 6. It is also understood that this Undertaking is provided for the purposes of undertaking joint and several liabilities of the partners to the Joint Venture for submission of the bid and performance of the Contract and that this Undertaking shall not be deemed to give rise to any additional liabilities or obligations, in any manner or any law, on any of the Parties to this Undertaking or on the Joint Venture, other than the express provisions of the Contract.
- 7. This Undertaking shall be construed and interpreted in accordance with the provisions of the Contract.
- 8. In case of an award of a Contract, we the parties to this Deed of Undertaking do hereby agree that we shall be jointly and severally responsible for furnishing a Contract performance security from a bank in favor of the Employer in the currency/currencies of the Contract.
- 9. It is further agreed that this Deed of Undertaking shall be irrevocable and shall form an integral part of the bid and shall continue to be enforceable till the Employer discharges the same or upon the completion of the Contract in accordance with its provisions, whichever is earlier. It shall be effective from the date first mentioned above for all purposes and intents.

IN WITNESS WHEREOF, the Parties to this Deed of Undertaking have through their authorized representatives executed these presents and affixed Common Seals of their companies, on the day, month and year first mentioned above.

Common Seal of .....  
 has been affixed in my/ our  
 presence pursuant to Board of  
 Director's Resolution dated .....

For Lead Partner (Party No.-1)  
 For and on behalf of M/s  
 .....

Name .....

Designation .....

Signature .....

(Signature of the authorized  
 representative)

WITNESS :

I. ....

II. ....

Common Seal of .....

For Party No.-2

has been affixed in my/ our presence pursuant to Board of Director's Resolution dated .....

For and on behalf of M/s.....

Name .....

(Signature of the authorized representative)

Designation .....

Signature .....

WITNESS :

I. ....

II. ....

Common Seal of ..... has been affixed in my/ our presence pursuant to Board of Director's Resolution dated .....

For Party No.-3 For and on behalf of M/s. ....

Name .....

Designation .....

Signature .....

(Signature of the authorized representative)

WITNESS :

I. ....

II. ....

**Note:**

1. For the purpose of executing the Joint Deed of Undertaking, the non-judicial stamp papers of appropriate value shall be purchased in the name of Joint Venture.
2. The Undertaking shall be signed on all the pages by the authorised representatives of each of the partners and should invariably be witnessed.
3. Appendix 1 must be enclosed

**(Appendix to Technical Part of the Bid)**

**Joint Venture Agreement**

**(no specified format, bidders to use own format)**

# Form 9

(Appendix to Technical Part of the Bid)

## Format for Details/ Data and Documentary Evidence in support of meeting the Qualification Requirement

### Notes on Form of Qualification Information

The information is to be filled in by individual bidders. The following pages will be used for purposes of post-qualification as provided for in Section 2 / Section 3 of RFB/ bidding documents. This information will not be incorporated in the Contract. Attach additional pages as necessary.

NIT/RFB No.: *[insert details]*  
Contract Title: *[insert details]*

Page \_\_\_\_\_ of \_\_\_\_\_ pages

### (Qualifying Requirement Data)

To:  
**Chief Engineer, IT**  
**WBSEDCL**  
**Vidyut Bhawan, 3<sup>rd</sup> Floor,**  
**Block-DJ, Sector-II,**  
**Bidhannagar, Kolkata-700091**

Bidder's Name and Address:  
*{ In case of JV bidder, mention name and address of all the Joint Venture members }*

Dear Ladies and/or Gentlemen,

In support of the Qualification Requirements (QR) for bidders, stipulated in Section-2 of the bidding documents, we furnish herewith our QR data/details/documents etc., along with other information, as follows (The QR stipulations have been reproduced in italics for ready reference, however, in case of any discrepancy the QR as given in Section-2 shall prevail).

\* We have submitted bid as individual firm.

\* We have submitted bid as joint venture of following firms:

- (i) .....
- (ii) .....

(\* *Strike-off whichever is not applicable*)

[For details regarding Qualification Requirements of a Joint Venture, please refer para 4.0 below.]

We are furnishing the following details/document in support of Qualifying requirement for the subject project.

I. Attached copies of original documents defining:

- a) The constitution or legal status;
- b) The principal place of business;
- c) The place of incorporation (for bidders who are corporations); or the place of registration and the nationality of the Owners (for applicants who are partnerships or individually-owned firms).

II. Attached original & copies of the following documents.

- a) Written power of attorney of the signatory of the Bid to commit the bidder.
- b)\*\* Joint Venture Agreement

*[\*\* To be submitted only in case of Joint Ventures. Strike off in case of individual firms.]*

**III. Technical Experience QR Data/ Details/ Document**

**Format A: Format for the Bidder (Single Firm / Partner(s) in case of Joint Venture) for technical experience in compliance to para 2.1 of Section-2 [In case of Joint Venture bidder, the QR data of each of the partner (in support of meeting the requirement of para 2.1.2 of Section-2)] is also to furnished, as applicable, using this format. The bidder (Single Firm / Partner(s) in case of Joint Venture) who is willing to qualify in compliance to para 2.1 of Section-2 shall fill below format for two or all three contracts.**

A1.	Name of Bidder/Lead Partner of JV/other partner(s) of JV	
A2.	Name of Contract (executed during the last 10 years up to 31.03.2023):	
A3.	Contract Reference No. & Date of Award	
A4	Name and Address of the Employer/Utility by whom the Contract was awarded  e-mail ID _____ Telephone No. _____ Fax No. _____	
A5(i)	Name of completed work of project execution in Eligible Projects in any Indian/Global (electricity) during the last ten (10) financial years:	_____ _____
(ii)	Cost of the project	
(iii)	% of cost w.r.t. estimated cost of this bid (in %)	
A6(i)	Date of successful execution of the Contract/Date of commissioning	<input type="checkbox"/> <input type="checkbox"/> <input type="checkbox"/>
A7.	Capacity in which the Contract was undertaken (Check One)	Prime Contractor Partner of JV Subcontractor <i>(Tick whichever is applicable)</i>
A8.	Details/documentary evidence submitted in support of stated experience/Contract	

(Documentary evidence, such as copies of contract agreement, letter of award, purchase order, work order, utility certificates, Completion Certificate, Go-Live Certificates in support

---

of the details presented above etc., in support of its experience shall be attached with the filled-up format for each experience/Contract)

## IV. Financial/ Commercial QE Data/ Details/ Documents

**Format B: Format for the Bidder (Single Firm / Partner(s) in case of Joint Venture) for financial/ commercial experience in compliance to para 2.2. of Section-2 [In case of Joint Venture bidder, the QR data of each of the partner (in support of meeting the requirement of para 2.2.4 of Section-2) is also to furnished, as applicable, using this format.**

A1.	Name of Bidder/Lead Partner of JV/other partner(s) of JV	
A2.	Net-worth in last three years 1. Financial Year 2020-21 2. Financial Year 2021-22 3. Financial Year 2022-23	: Rs ----- lakhs : Rs ----- lakhs : Rs ----- lakhs
A3.	Details/documentary evidence submitted in support of stated details	

V. We understand that:



- i. . Sub contractors' experience and resources shall not be taken into account in determining the bidder's compliance with qualifying criteria.
- ii. One of the partners shall be nominated as lead partner, and the lead partner shall be authorized to incur liabilities and receive instruction for and on behalf of any and all partners of the joint venture and the entire execution of the contract including receipt of payment shall be done exclusively through the lead partner. This authorization shall be evidenced by submitting a power of attorney signed by legally authorized signatories of all the partners as per specified format.
- iii. All partner of the joint venture shall be liable jointly and severally for the execution of the contract in accordance with the contract terms and a copy of the agreement entered into by the joint venture partners having such a provision shall be submitted with the bid.

VI. We have furnished the following documents/details with Technical Part of our Bid:

- 2.1 A certificate from banker (as per format) indicating various fund based/non fund based limits sanctioned to the bidder and the extent of utilization as on date. Such certificate should have been issued not earlier than three months prior to the date of bid opening. Wherever necessary Employer may make queries with the Bidders' bankers.
- 2.2 The complete annual reports together with Audited statement of accounts of the company for last five years of its own (separate) immediately preceding the date of submission of bid.

Note:

- (a) In the event the bidder is not able to furnish the information of its own (i.e. separate), being a subsidiary company and its accounts are being consolidated with its group/holding/parent company, the bidder should submit the audited balance sheets, income statements, other information pertaining to it only (not of its group/Holding/Parent Company) duly certified by any one of the authority [(i)

Statutory Auditor of the bidder / (ii) Company Secretary of the bidder or (iii) A certified Public Accountant] certifying that such information/documents are based on the audited accounts as the case may be.

(b) Similarly, if the bidder happens to be a Group/Holding/Parent Company, the bidder should submit the above documents/information of its own (i.e. exclusive of its subsidiaries) duly certified by any one of the authorities mentioned in Note – 2.3 above certifying that these information/ documents are based on the audited accounts, as the case may be.

Dated the ..... [Insert date of the month] day of ..... [Insert month, year]  
at ..... [Insert place].

\_\_\_\_\_  
Signature {(of Bidder's authorized Bid Signatory (ies))<sup>#</sup> {In full and initials}}:

Full name: {insert full name of authorized Bid Signatory }

Title: {insert title/position of authorized Bid Signatory }

Name of Bidder (Sole Bidder's name or Consortium/ JV's name, if applicable):

Capacity: {insert the person's capacity to sign for the Bidder}

Address: {insert the authorized Bid Signatory's address}

Phone/fax: {insert the authorized Bid Signatory's phone and fax number, if applicable}

Email: {insert the authorized Bid Signatory's email address} \_\_\_\_\_

<sup>#</sup>{For a joint venture, either all members shall sign or only the authorised signatory as per ITB 19.4, in either case the power of attorney of the authorized bid signatory (signatories) must be attached}

**Form 10**

(Appendix to Technical Part of the Bid)

**Format of Bought-out & Sub-contracted Items**NIT/RFB No.: *[insert details]*Contract Title: *[insert details]*

Page \_\_\_\_\_ of \_\_\_\_\_ pages

To,  
**Chief Engineer , IT**  
**WBSEDCL**  
**Vidyut Bhawan, 3<sup>rd</sup> Floor,**  
**Block-DJ, Sector-II,**  
**Bidhannagar, Kolkata-700091**

Bidder's Name and Address:

*{In case of JV bidder, mention name  
and address of all the Joint Venture members}*

Dear Sir/ Madam,

1.0 We hereby furnish the details of major items/ sub-assemblies, we propose to buy from our proposed sub-vendors/ subcontractors for the purpose of supply of Plant and Installation Services under the subject Project:

Sl. No.	Item Description	Quantity proposed to be bought-out/sub-contracted	Details of the proposed sub-contractor/sub-vendor	
			Name	Nationality
1.				
2.				
3.				
4.				
5.				
6.				

2.0 *We hereby declare that, in the event of award of Contract on us, we would not subcontract any portion of Installation Services under Part II of the Contract (Supply of Installation Services) and*

*any major item other than those mentioned above under Part I of the Contract (Supply of Plant) without the prior approval of Employer as per the provisions of the Contract. We understand that for subcontract related to hiring of labour, prior approval of the Employer is not required.*

**3.0 We hereby declare that total local content that will be sourced in the bid is more than 50% of the total content required under the project.**

Dated the ..... [Insert date of the month] day of..... [Insert month, year]  
at..... [Insert place].

\_\_\_\_\_  
Signature {(of Bidder’s authorized Bid Signatory (ies))<sup>#</sup> {In full and initials}}:

Full name: {insert full name of authorized Bid Signatory }  
Title: {insert title/position of authorized Bid Signatory }  
Name of Bidder (Sole Bidder’s name or Consortium/ JV’s name, if applicable):  
Capacity: {insert the person’s capacity to sign for the Bidder }  
Address: {insert the authorized Bid Signatory’s address }  
Phone/fax: {insert the authorized Bid Signatory’s phone and fax number, if applicable }  
Email: {insert the authorized Bid Signatory’s email address }\_\_\_\_\_

<sup>#</sup>{For a joint venture, either all members shall sign or only the authorised signatory as per ITB 19.4, in either case the power of attorney of the authorized bid signatory (signatories) must be attached}

## Form 11

(Appendix to Technical Part of the Bid)

### Format of Undertaking on Compliance of Terms & Conditions of the Bidding Documents including Scope of Work and other related requirements

#### UNDERTAKING ON COMPLIANCE OF RFB TERMS & CONDITIONS AND OTHER REQUIREMENTS

**(To be submitted on ₹100 Stamp paper issued in the State where Bidder's office is located, duly signed by the authorized signatory)**

I/We hereby undertake that I/We have examined/ perused, studied and understood the Request For Bid (RFB) Document in respect of RFB no \_\_\_\_\_ dated \_\_\_\_\_ and any corrigendum/ addendum/ clarification etc. thereto completely and have submitted my/our Proposal/ Bid in pursuance to the said RFB document for [insert Contract Title].

I/We hereby undertake that I/We understand that the scope of Services and other related requirement under and in pursuance of this RFB are indicative only and not exhaustive in any manner. I/We understand that the scope of Services may undergo changes as per emerging requirements of WBSEDCL as specified in the RFB document.

I/We hereby undertake that we shall comply with the scope of Services and other related requirements and the terms and conditions specified in the RFB document completely and except as mentioned in the Form 12 (Alternative, Deviations and Exceptions to the Provisions) hereof, we have no deviations and/or submissions and/or clarifications, whatsoever of any manner and/or sort and/or kind in this regard.

I/We hereby undertake to provide any further clarifications, details, documents etc. as may be required without changing the substance of our Proposal.

I/We understand that the WBSEDCL reserves the right to float a separate Request For Bid/ Notice Inviting Tender/ Invitation for Bids for the scope of Work and related requirements as covered under this RFB, irrespective of the outcome of this RFB, and I/We hereby undertake that we have no objection for the same. I/We understand that in such a case, I/We shall bid separately in response to such Request For Bid/ Notice Inviting Tender/ Invitation for Bids, and in no case our bid/ Proposal in response to this RFB shall be deemed as a Proposal/ Bid in response to such Request For Bid/ Notice Inviting Tender/ Invitation for Bids.

I/We hereby undertake to provide the Plant and Installation Services and undertake to be the single point of contact for WBSEDCL for complete Scope of Work and related

requirements as per the terms and conditions and as specified in this RFB document.

I/We hereby undertake that except as mentioned in the Form 12 (Alternative, Deviations and Exceptions to the Provisions) hereof, my/our bid is/ deemed to be as per the RFB document and is accordingly submitted to the WBSEDCL. In case of a failure to comply and/or variation WBSEDCL has the sole discretion not to consider or disqualify my/our Proposal/ bid for the aforementioned RFB and I/We shall not have any claim of any sort/ kind/ form on the same.

I/We agree to be bound by our Proposal for the period of validity as specified in and required as per Section 3 of RFB document and it shall remain binding upon us and may be accepted at any time before the expiration of that validity period as may be extended by us.

I/We hereby attach the duly signed and stamped RFB document as an unconditional acceptance and compliance of RFB specifications and terms & conditions as part of the Technical Part of our Bid without any deviations and/or submissions and/or clarifications of any manner and/or sort and/or kind in this regard, except as indicated in Form 12 (Alternative, Deviations and Exceptions to the Provisions) hereof ~~from my/our side.~~

**I/We understand that mentioning of any pre-requisites, presumptions, assumptions, hiding/ twisting/ deletion/ reduction/ manipulation/ disguising of Scope of Works and/or application features and/or infrastructure and/or project deliverables etc. in any form and/or by any means and/or under any head shall not be constituted as a part of the Bid/ Proposal and in case of award of the Contract the same shall not be claimed by me/us while award and/or subsequently providing of Plant and Installation Services/ execution of work. The decision of WBSEDCL on such issues shall be binding on me/us and the same shall not be arbitrated upon by me/us.**

**I/We hereby undertake that we abide by all the terms and conditions mentioned in the RFB document along with amendment/corrigendum/ clarification, if any, as confirmed herein**

We also confirm that in case any discrepancies/ inconsistencies and deviations/ omissions/ reservations, except as indicated in Form 12 (Alternative, Deviations and Exceptions to the Provisions) hereof, is observed in the online Price Part of our Bid, the same shall be deemed as withdrawn/rectified without any financial implication, whatsoever to WBSEDCL.

I/We understand that at any stage during the tenure of the Contract if it is found that any statement or document submitted by us is false/forged/invalid, WBSEDCL has discretion to terminate the Contract and get the Plant and Installation Services delivered / work done through third party.

I/We hereby affirm that the products and/or Plant and Installation Services offered by us against this RFB are in compliance to the latest Government of India Guidelines and circulars which will remain complied to the same during the duration and execution of this assignment.

I/We also hereby affirm the following:

- a) I/ we are not insolvent, in receivership, bankrupt or being wound up, not have our affairs administered by a court or a judicial officer, not have our business activities suspended and am/ are not the subject of legal proceedings for any of the foregoing reasons;
- b) I/ we have not, and our directors and officers have not, been convicted of any criminal offence related to our/ their respective professional conduct or the making of false statements or misrepresentations as to our/ their qualifications to enter into a procurement contract within a period of two years preceding the commencement of this procurement process, or have not been otherwise disqualified pursuant to debarment proceedings;
- c) I/ we do not have a Conflict of Interest in the procurement in question as specified in the RFB document.
- d) I/ we comply with the code of integrity and other requirements as specified in the RFB document.

Dated the ..... *[Insert date of the month]* day of..... *[Insert month, year]* at..... *[Insert place]*.

Signature {(of Bidder’s authorized Bid Signatory (ies))<sup>#</sup> {In full and initials}}:

Full name: {insert full name of authorized Bid Signatory }  
 Title: {insert title/position of authorized Bid Signatory }  
 Name of Bidder (Sole Bidder’s name or Consortium/ JV’s name, if applicable):  
 Capacity: {insert the person’s capacity to sign for the Bidder}  
 Address: {insert the authorized Bid Signatory’s address}  
 Phone/fax: {insert the authorized Bid Signatory’s phone and fax number, if applicable}  
 Email: {insert the authorized Bid Signatory’s email address}\_\_\_\_\_

<sup>#</sup>{For a joint venture, either all members shall sign or only the authorised signatory as per ITB 19.4, in either case the power of attorney of the authorized bid signatory (signatories) must be attached}

**Form 12**

(Appendix to Technical Part of the Bid)

**Format of Alternative, Deviations and Exceptions to the Provisions of RFB Document**NIT/RFB No.: *[insert details]*Contract Title: *[insert details]*

Page \_\_\_\_\_ of \_\_\_\_\_ pages

To,  
**Chief Engineer, IT**  
**WBSEDCL**  
**Vidyut Bhawan, 3<sup>rd</sup> Floor,**  
**Block-DJ, Sector-II,**  
**Bidhannagar, Kolkata-700091**

Bidder's Name and Address:

*{In case of JV bidder, mention name  
and address of all the Joint Venture members}*

Dear Sir/ Madam,

*The bidder shall itemize any deviation from the Specifications included in his bid. Each item shall be listed (separate sheets may be used and enclosed with this Attachment) with the following information:*

<b>Sl. No.</b>	<b>Reference clause in the Specifications</b>	<b>Deviation</b>	<b>Cost of withdrawal of the deviation</b>

The above deviations and variations are exhaustive. We confirm that we shall withdraw the deviations proposed by us at the cost of withdrawal indicated in this attachment, failing which our bid may be rejected and Bid Security forfeited.

Except for the above deviations and variations, the entire work shall be performed as per your specifications and documents. Further, we agree that any deviations, conditionality or



reservation introduced in this Attachment-6 and/or in the Bid form, Price schedules & Technical Data Sheets and covering letter, or in any other part of the bid will be reviewed to conduct a determination of the substantial responsiveness of the bid.

Dated the ..... *[Insert date of the month]* day of..... *[Insert month, year]*  
at..... *[Insert place]*.

---

Signature {(of Bidder's authorized Bid Signatory (ies))<sup>#</sup> {In full and initials}}:

Full name: {insert full name of authorized Bid Signatory }

Title: {insert title/position of authorized Bid Signatory }

Name of Bidder (Sole Bidder's name or Consortium/ JV's name, if applicable):

Capacity: {insert the person's capacity to sign for the Bidder }

Address: {insert the authorized Bid Signatory's address }

Phone/fax: {insert the authorized Bid Signatory's phone and fax number, if applicable }

Email: {insert the authorized Bid Signatory's email address }\_\_\_\_\_

<sup>#</sup>*{For a joint venture, either all members shall sign or only the authorised signatory as per ITB 19.4, in either case the power of attorney of the authorized bid signatory (signatories) must be attached}*

**Form 13**

(Appendix to Technical Part of the Bid)

**Format of Work Completion Schedule**NIT/RFB No.: *[insert details]*Contract Title: *[insert details]*

Page \_\_\_\_\_ of \_\_\_\_\_ pages

**To,  
Chief Engineer , IT  
WBSEDCL  
Vidyut Bhawan, 3<sup>rd</sup> Floor,  
Block-DJ, Sector-II,  
Bidhannagar, Kolkata-700091**

Bidder's Name and Address:

Dear Sir/ Madam,

We hereby declare that the following Work Completion Schedule shall be followed by us in furnishing and installation of the subject Project for the period commencing from the effective date of Contract to us:

<b>Sl. No.</b>	<b>Description of Work</b>	<b>Period in months from the effective date of Contract</b>
1.	a)	
2.	a)	

3.		
----	--	--

Sl. No.	Description of Work	Period in months from the effective date of Contract
4.	Manufacturing a) commencement b) completion	
5.	Shipments & Delivery a) commencement b) completion	
6.	Establishment of site office	
7.	Installation at Site a) commencement b) completion	
8.	Testing & Pre-commissioning a) commencement b) completion	
9.	Trial Operation a) commencement b) completion	

Notwithstanding the above we reiterate our compliance to the Time for Completion of the Facilities/ Works as per the provisions of the RFB document.

Dated the ..... [Insert date of the month] day of..... [Insert month, year] at..... [Insert place].

Signature {(of Bidder’s authorized Bid Signatory (ies))}# {In full and initials}:

Full name: {insert full name of authorized Bid Signatory }  
Title: {insert title/position of authorized Bid Signatory }  
Name of Bidder (Sole Bidder's name or Consortium/ JV's name, if applicable):  
Capacity: {insert the person's capacity to sign for the Bidder}  
Address: {insert the authorized Bid Signatory's address}  
Phone/fax: {insert the authorized Bid Signatory's phone and fax number, if applicable}  
Email: {insert the authorized Bid Signatory's email address}\_\_\_\_\_

*#{For a joint venture, either all members shall sign or only the authorised signatory as per ITB 19.4, in either case the power of attorney of the authorized bid signatory (signatories) must be attached}*

Note: Bidders to enclose a detailed network covering all the activities to be undertaken for completion of the project indicating key dates for various milestones for each phase constituent-wise.

**Form 14****(Appendix to Technical Part of the Bid)****Format of Guarantee Declaration**NIT/RFB No.: *[insert details]*Contract Title: *[insert details]*

Page \_\_\_\_\_ of \_\_\_\_\_ pages

**To,  
 Chief Engineer, IT  
 WBSEDCL  
 Vidyut Bhawan, 3<sup>rd</sup> Floor,  
 Block-DJ, Sector-II,  
 Bidhannagar, Kolkata-700091**

Bidder's Name and Address:

*{In case of JV bidder, mention name  
 and address of all the Joint Venture members}*

Dear Sir/ Madam,

We confirm that the plant/ equipment/ goods/ material offered shall have minimum (or maximum, as the case may be) of the performance specified in the RFB document/ Employer's Requirement/ Specification/ Scope of Work. We further guarantee the performance/ efficiency of the plant/ equipment/ goods/ material offered in response to RFB document/ Employer's Requirement/ Specification/ Scope of Work.

Dated the ..... *[Insert date of the month]* day of ..... *[Insert month, year]*  
 at ..... *[Insert place]*.

\_\_\_\_\_  
 Signature {(of Bidder's authorized Bid Signatory (ies))<sup>#</sup> {In full and initials}}:

Full name: {insert full name of authorized Bid Signatory }

Title: {insert title/position of authorized Bid Signatory }

Name of Bidder (Sole Bidder's name or Consortium/ JV's name, if applicable):

Capacity: {insert the person's capacity to sign for the Bidder }

Address: {insert the authorized Bid Signatory's address }

Phone/fax: {insert the authorized Bid Signatory's phone and fax number, if applicable }

Email: {insert the authorized Bid Signatory's email address } \_\_\_\_\_

*# {For a joint venture, either all members shall sign or only the authorised signatory as per ITB 19.4, in either case the power of attorney of the authorized bid signatory (signatories) must be attached}*

**Form 15**

(Appendix to Technical Part of the Bid)

**Format of Information regarding Ex-employees**

(The information in similar format should be furnished for each partner of joint venture in case of joint venture bid)

NIT/RFB No.: [insert details]

Contract Title: [insert details]

Page \_\_\_\_\_ of \_\_\_\_\_ pages

To,  
**Chief Engineer ,IT**  
**WBSEDCL**  
**Vidyut Bhawan, 3<sup>rd</sup> Floor,**  
**Block-DJ, Sector-II,**  
**Bidhannagar, Kolkata-700091**

Bidder's Name and Address:  
*{In case of JV bidder, mention name  
and address of the concerned Joint Venture member}*

Dear Sir/ Madam,

)

**(Information regarding Ex-employees of WBSEDCL (Name of Employer) in  
our Organization)**

Dear Sir/ Madam,

We hereby furnish the details of ex-employees of **WBSEDCL (Name of Employer)** who had retired/ resigned at the level of {.....} (*Define suitable post*) from **WBSEDCL (Name of Employer)** and subsequently have been employed by us:

---

Sl. No. with designation in {.....}(Name of Employer)	Date of Retirement/ resignation from {.....}(Name of Employer)	Date of joining and designation in our Organization
---	---	---



1. ....
2. ....
3. ....

Dated the ..... *[Insert date of the month]* day of..... *[Insert month, year]*  
 at..... *[Insert place]*.

Signature {(of Bidder’s authorized Bid Signatory (ies))<sup>#</sup> {In full and initials}}:

Full name: {insert full name of authorized Bid Signatory }  
 Title: {insert title/position of authorized Bid Signatory }  
 Name of Bidder (Sole Bidder’s name or Consortium/ JV’s name, if applicable):  
 Capacity: {insert the person’s capacity to sign for the Bidder }  
 Address: {insert the authorized Bid Signatory’s address }  
 Phone/fax: {insert the authorized Bid Signatory’s phone and fax number, if applicable }  
 Email: {insert the authorized Bid Signatory’s email address }\_\_\_\_\_

<sup>#</sup>{*For a joint venture, either all members shall sign or only the concerned member and authorised signatory as per ITB 19.4, in either case the power of attorney of the authorized bid signatory (signatories) must be attached*}

Note: .

**Form 16**

(Appendix to Technical Part of the Bid)

**Format for Price Adjustment Data**NIT/RFB No.: *[insert details]*Contract Title: *[insert details]*

Page \_\_\_\_\_ of \_\_\_\_\_ pages

To,  
**Chief Engineer , IT**  
**WBSEDCL**  
**Vidyut Bhawan, 3<sup>rd</sup> Floor,**  
**Block-DJ, Sector-II,**  
**Bidhannagar, Kolkata-700091**

Bidder's Name and Address:  
*{In case of JV bidder, mention name  
and address of all the Joint Venture members}*

Dear Sir/ Madam,

We hereby furnish the details of Price Adjustments:

<b>Name of Material***</b>	<b>Price as on 30 days prior to date of bid opening*</b>	<b>Price as on XX days prior to date of shipment*</b>	<b>Variation*</b>

\*Detailed calculations as per **Appendix-2 of Form 5** to be enclosed

\*\* Not to be filled at the time of bid submission

\*\*\* The materials listed are illustrative, a separate row to be created for each material for indicating price adjustment

Dated the ..... *[Insert date of the month]* day of..... *[Insert month, year]*  
at..... *[Insert place]*.

---

Signature {(of Bidder's authorized Bid Signatory (ies))<sup>#</sup> {In full and initials}}:

Full name: {insert full name of authorized Bid Signatory }

Title: {insert title/position of authorized Bid Signatory }

Name of Bidder (Sole Bidder's name or Consortium/ JV's name, if applicable):

Capacity: {insert the person's capacity to sign for the Bidder }

Address: {insert the authorized Bid Signatory's address }

Phone/fax: {insert the authorized Bid Signatory's phone and fax number, if applicable }

Email: {insert the authorized Bid Signatory's email address }\_\_\_\_\_

<sup>#</sup>{*For a joint venture, either all members shall sign or only the concerned member and authorised signatory as per ITB 19.4, in either case the power of attorney of the authorized bid signatory (signatories) must be attached*}

**Form 17**

(Appendix to Technical Part of the Bid)

**Format of Option for Initial Advance (either Interest Bearing Initial Advance or No Initial Advance) and Information for E-payment, PF details and declaration regarding Micro/Small & Medium Enterprises**NIT/RFB No.: *[insert details]*Contract Title: *[insert details]*

Page \_\_\_\_\_ of \_\_\_\_\_ pages

To,  
**Chief Engineer, IT**  
**WBSEDCL**  
**Vidyut Bhawan, 3<sup>rd</sup> Floor,**  
**Block-DJ, Sector-II,**  
**Bidhannagar, Kolkata-700091**

Bidder's Name and Address:  
*{In case of JV bidder, mention name  
and address of all the Joint Venture members}*

Dear Sir/ Madam,

- I. We have read the provisions in the Bidding Documents regarding the option for advance payment. Accordingly, we hereby confirm to opt the following:

Interest Bearing Initial Advance

Supply of Plant Portion :        Yes\*    [   ]            No\* [   ]

Supply of Installation Services Portion :    Yes^ [   ]            No^ [   ]

(\*^ tick ONLY ONE of the selected options)

- II. We are furnishing the following details of Statutory Registration Numbers and details of Bank for electronic payment.

1.	Name of the Supplier/ Contractor in whose favour payment is to be made	
----	--	--

2.	Address with PIN Code and State	Registered Office:  Branch Office:  Correspondence Address:
3.	Status – Company/others [Declaration of Micro/ Small/ Medium Enterprise under Micro/ Small & Medium Enterprises Development Act 2006, if applicable]	
4.	Permanent Account (PAN) No.	
5.	Goods and Services Tax Registration No..	
6.	PF Registration No. of the Company	
7.	PF Regional Office covered (with Address)	
8.	Name of Contact Person	
9.	Telephone No(s).  Email	Landline(s):  Mobile(s):  Email ID :
10.	Bank Details for Electronic Payment	Name of the Bank:

		Address of Branch:  Account No.: Type of Account:  <input type="checkbox"/> Saving  <input type="checkbox"/> Current
11.	9 digit MICR code printed at bottom in middle, next to cheque no.	
12.	IFSC (for RTGS)/NEFT Code <i>(to be obtained from the Bank)</i>  <b><i>Sample Cancelled Cheque to be enclosed</i></b>	

We hereby declare that the above information is true and correct and we agree that the payment on account of this Contract, in the event of award, be made in the above account maintained in the above mentioned Bank.

Dated the ..... *[Insert date of the month]* day of..... *[Insert month, year]*  
 at..... *[Insert place]*.

---

Signature {(of Bidder's authorized Bid Signatory (ies))<sup>#</sup> {In full and initials}}:

Full name: {insert full name of authorized Bid Signatory }

Title: {insert title/position of authorized Bid Signatory }

Name of Bidder (Sole Bidder's name or Consortium/ JV's name, if applicable):

Capacity: {insert the person's capacity to sign for the Bidder }

Address: {insert the authorized Bid Signatory's address }

Phone/fax: {insert the authorized Bid Signatory's phone and fax number, if applicable }

Email: {insert the authorized Bid Signatory's email address }\_\_\_\_\_

**Form 18**

(Appendix to Technical Part of the Bid)

**FORMAT OF Declaration for tax exemptions, reductions, allowances or benefits)**

NIT/RFB No.: [insert details/  
Contract Title: /insert details/

Page\_\_\_\_\_of\_\_\_\_\_pages

**To,  
Chief Engineer, IT  
WBSEDCL  
Vidyut Bhawan, 3<sup>rd</sup> Floor,  
Block-DJ, Sector-II,  
Bidhannagar, Kolkata-700091**

Bidder's Name and Address:  
{In case of JV bidder, mention name  
and address of all the Joint Venture members}

Dear Sir / Madam,

1. We confirm that we are solely responsible for obtaining following tax exemptions, reductions, allowances or benefits in respect of supplies under the subject Project, in case of award. We further confirm that we have considered the same in our bid thereby passing on the benefit **to the Chief Engineer, IT, WBSEDCL** while quoting our prices. In case of our failure to receive such benefits, partly or fully, for any reason whatsoever, the Employer will not compensate us.
2. We are furnishing the following information required by the Employer for issue of requisite certificate if and as permitted in terms of the applicable Govt. of India policies/procedures (in case of award):

Applicable Act, Notification No. and Clause Ref. No.	Sl. No.	Description of item on which applicable	Country of origin	Remarks, if any



*(The requirements listed above are as per current Notification of Govt. of India indicated above. These may be modified, if necessary, in terms of the Notifications.)*

Dated the ..... *[Insert date of the month]* day of..... *[Insert month, year]*  
at..... *[Insert place]*.

---

Signature {(of Bidder's authorized Bid Signatory (ies))<sup>#</sup> {In full and initials}}:

Full name: {insert full name of authorized Bid Signatory }

Title: {insert title/position of authorized Bid Signatory }

Name of Bidder (Sole Bidder's name or Consortium/ JV's name, if applicable):

Capacity: {insert the person's capacity to sign for the Bidder }

Address: {insert the authorized Bid Signatory's address }

Phone/fax: {insert the authorized Bid Signatory's phone and fax number, if applicable }

Email: {insert the authorized Bid Signatory's email address }\_\_\_\_\_

**Form 19****(Appendix to Technical Part of the Bid)****Format of Bank Guarantee verification Check list**

NIT/RFB No.: [insert details/

Contract Title: [insert details/

Page \_\_\_\_\_ of \_\_\_\_\_ pages

To,  
**Chief Engineer, IT**  
**WBSEDCL**  
**Vidyut Bhawan, 3<sup>rd</sup> Floor,**  
**Block-DJ, Sector-II,**  
**Bidhannagar, Kolkata-700091**

Bidder's Name and Address:

*{In case of JV bidder, mention name  
and address of all the Joint Venture members}*

**(Bank Guarantee verification Check list)**

Dear Sir/ Madam

We have ensured compliance to the following checklist in submission of Bank Guarantee :

<b>S. No.</b>	<b>Checklist</b>	<b>Yes</b>	<b>No</b>
1	Does the bank guarantee compare verbatim with standard proforma for BG?		
2(a)	Has the executing Officer of BG indicated his name designation & Power of Attorney No. / Signing power Number etc. on BG?		
2(b)	Is each page of BG duly Signed/ initialed by the executants and last page is signed with full particulars as required in the standard proforma of BG and under the seal of the bank?		
2(c)	Does the last page of the BG carry the signatures of two witnesses alongside the signature of the executing Bank Manager?		
3(a)	Is the BG on non-judicial stamp paper of appropriate value?		

3(b)	Is the date of sale of non-judicial stamp paper shown on the BG and the stamp paper is issued not more than Six months prior to the date of execution of BG?		
4(a)	Are the factual details such as Bid specification No., LOA No. contract price, etc, correct?		
4(b)	Whether Overwriting /cutting, if any on the BG, authenticated under signature & seal of executants?		
5	Is the amount and validity of BG is in line with contract provisions?		
6	Whether the BG has been issued by a Nationalized bank / Non- Nationalized Bank acceptable to Buyer /Scheduled Bank in India (the applicability of the bank should be in line with the provisions of bidding documents)?		

Dated the ..... *[Insert date of the month]* day of..... *[Insert month, year]*  
at..... *[Insert place]*.

Signature {(of Bidder's authorized Bid Signatory (ies))<sup>#</sup> {In full and initials}}:

Full name: {insert full name of authorized Bid Signatory }

Title: {insert title/position of authorized Bid Signatory }

Name of Bidder (Sole Bidder's name or Consortium/ JV's name, if applicable):

Capacity: {insert the person's capacity to sign for the Bidder}

Address: {insert the authorized Bid Signatory's address}

Phone/fax: {insert the authorized Bid Signatory's phone and fax number, if applicable}

Email: {insert the authorized Bid Signatory's email address}\_\_\_\_\_

(Common Seal).....

**Appendix to Technical Part**  
**Attachment-4A : List of Special Maintenance Tools & Tackles included in bid price**

**(List of Special Maintenance Tools & Tackles)**

**To,**  
**Chief Engineer, IT**  
**WBSEDCL**  
**Vidyut Bhawan, 3<sup>rd</sup> Floor,**  
**Block-DJ, Sector-II,**  
**Bidhannagar, Kolkata-700091**

Bidder's Name and Address:

Dear Sir,

We are furnishing below the list of special maintenance tools & tackles for various equipment under the subject project. The prices for these tools & tackles are included in our lumpsum bid price. We further confirm that the list of special maintenance tools & tackles includes all the items specifically identified in your bidding documents as brought out below:

-----

--

S.No.	For Equipment	Item Description	Unit	Quantity
-----				
--				
-----				
--				

Notwithstanding what is stated above, we further confirm that any additional special maintenance tools and tackles, required for the equipment under this project shall be furnished by us at no extra cost to the employer.

Date:.....

(Signature).....

Place:.....

(Printed Name).....

(Designation).....

(Common Seal).....

**Appendix to Technical Part  
Attachment-4B : List of Special Maintenance Tools & Tackles not included in bid price**

**(List of Special Maintenance Tools & Tackles)**

**To,  
Chief Engineer, IT  
WBSEDCL  
Vidyut Bhawan, 3<sup>rd</sup> Floor,  
Block-DJ, Sector-II,  
Bidhannagar, Kolkata-700091**

Bidder's Name and Address:

Dear Sir,

We are furnishing below the list of special maintenance tools & tackles for various equipment under the subject Project. The prices for these tools & tackles which are to be taken back after the completion of the work by us are not included in our lumpsum bid price. We further confirm that the list of special maintenance tools & tackles includes all the items specifically identified in your bidding documents as brought out below:

(a) .....

(b) .....

Date:.....

(Signature).....

Place:.....

(Printed Name).....

(Designation).....

(Common Seal).....

**Form 20****(Appendix to Technical Part of the Bid)****Format of Additional Information**

NIT/RFB No.: [insert details/]

Contract Title: [insert details/]

Page \_\_\_\_\_ of \_\_\_\_\_ pages

**To,  
Chief Engineer, IT  
WBSEDCL  
Vidyut Bhawan, 3<sup>rd</sup> Floor,  
Block-DJ, Sector-II,  
Bidhannagar, Kolkata-700091**

Bidder's Name and Address:

*{In case of JV bidder, mention name  
and address of all the Joint Venture members}*

**(Additional Information)**

Dear Sir/ Madam,

In support of the additional information required as per the Bidding Documents, we furnish herewith our data/details/documents etc., along with other information, as follows (the stipulations have been reproduced in italics for ready reference):

**1.0** *The Bidder shall furnish*

*A certificate from their Banker(s) indicating various fund based/non fund based limits sanctioned to the Bidder and the extent of utilization as on date. Such certificate should have been issued not earlier than three months prior to the date of bid opening. Wherever necessary the Employer may make queries with the Bidders' Bankers. [Reference Part -1, Section 2]*

**1.1** In accordance with 1.0, certificate(s) from banker as per requisite format, indicating various fund based/non fund based limits sanctioned to the bidder or each member of

the joint venture and the extent of utilization as on date is/are enclosed, as per the following details:

Name of the Bidder/partner of Joint Venture	
Name of the Banker by whom certificate issued	
Date of certificate (should not be earlier than <b>3 months</b> prior to date of bid opening)	
Whether fund based/non fund based limits are indicated in the certificate	
Whether extent of utilization is indicated in the certificate	

1.2 *The Bidder should accordingly also provide the following information/documents (**In case of JV bidders, information should be provided separately for all the Partners of JV in the given format**):*

(i) Details of Banker:

Name of Banker	
Address of Banker	_____ _____ _____
Telephone No.	_____
Contact Name and Title	_____
Fax No.	_____
E-mail ID	_____

As per para 1.0, Authorization Letter(s) from the bidder (in case of JV bidder, from all the partners) addressed to the Banker(s), authorize **Chief Engineer, IT, WBSEDCL**





4. Current Liability										
5. Profit before taxes										
6. Profit after taxes										

3. The information/documentation in support of Bidder’s design infrastructure and erection facilities and capacity and procedures including quality control related to the work, are enclosed at \_[.....]\_\_\_\_\_ herewith.
  
4. The CV and experience details of a project manager experience(as per section 6 ) in executing such contract of comparable nature including not less than five years as manager and the CVs of other employees to be deputed for the subject work, are enclosed at \_[.....]\_herewith.

Dated the ..... *[Insert date of the month]* day of..... *[Insert month, year]*  
 at..... *[Insert place]*.

\_\_\_\_\_  
 Signature {(of Bidder’s authorized Bid Signatory (ies)}# {In full and initials}:

Full name: {insert full name of authorized Bid Signatory }  
 Title: {insert title/position of authorized Bid Signatory }  
 Name of Bidder (Sole Bidder’s name or Consortium/ JV’s name, if applicable):  
 Capacity: {insert the person’s capacity to sign for the Bidder}  
 Address: {insert the authorized Bid Signatory’s address}  
 Phone/fax: {insert the authorized Bid Signatory’s phone and fax number, if applicable}  
 Email: {insert the authorized Bid Signatory’s email address}\_\_\_\_\_  
 (Common Seal).....

## Form 21

(Appendix to Technical Part of the Bid)

### Format of Integrity Pact

#### INTEGRITY PACT

#### PRE-CONTRACT INTEGRITY PACT

##### GENERAL

This pre-bid contract Agreement (herein after called the Integrity Pact) is made on \_\_\_\_\_ day of the month of \_\_\_\_\_ 20... , between, on one hand, the WBSEDCL Acting through Shri....., Designation of the officer, (hereinafter called the "WBSEDCL", which expression shall mean and include, unless the context otherwise requires, his successors in the office and assigns) of the First Part and M/s. \_\_\_\_\_ represented by Shri \_\_\_\_\_ (hereinafter called the "BIDDER/SUPPLIER", which expression shall mean and include, unless the context otherwise requires, his successors and permitted assigns) of the Second Part.

WHEREAS the WBSEDCL propose to procure Plant and Installation Services as per the Scope of Work Mentioned in the RFB document (hereinafter called the "Facilities", against RFB No. [.....] for [Contract Title] which expression shall mean and include, unless the context otherwise requires, any additions & deletions in the said "Facilities") and the BIDDER/ Supplier is willing to offer/has offered the said "Facilities".

WHEREAS the BIDDER/ Supplier is a Private Company/Public Company/LLP/ Government Undertaking/ Partnership/Proprietorship, constituted in accordance with the relevant law in the matter and the WBSEDCL is a Ministry /Department of the Government of West Bengal /SPSU performing its function on behalf of the Governor of West Bengal.

NOW, THEREFORE,

To avoid all forms of corruption by following a system that is fair, transparent and free from any influence/prejudiced dealings prior to, during and subsequent to the currency of the Contract to be entered into with a view to:-

Enabling the WBSEDCL to obtain the desired "Facilities" at a competitive price in conformity with the defined specifications by avoiding the high cost and the distortionary impact of corruption on public procurement, and

Enabling BIDDER/ SUPPLIER to abstain from bribing or indulging in any corrupt practice in order to secure the contract by providing assurance to them that their competitors will also abstain from bribing and other practices and the WBSEDCL will commit to prevent corruption, in any form, by its official by following transparent procedures.

The parties hereto hereby agree to enter into this Integrity Pact and agree as follows:  
Commitments of the WBSSEDCL

1.
  - 1.1. The WBSSEDCL undertakes that no official of the WBSSEDCL, connected directly or indirectly with the contract, will demand, take a promise for or accept, directly or through intermediaries, any bribe, consideration, gift, reward, favour or any material or immaterial benefit or any other advantage from the BIDDER/SUPPLIER, either for themselves or for any person, organization or third party related to the contract in exchange for an advantage in the bidding process, bid evaluation, contracting or implementation process related to the contract.
  - 1.2. The WBSSEDCL will, during the pre-contract stage, treat all BIDDER/SUPPLIER alike, and will provide to all BIDDER/SUPPLIER the same information and will not provide any such information to any particular BIDDER/SUPPLIER which could afford an advantage to that particular BIDDER/SUPPLIER in comparison to the other BIDDER(S)/SUPPLIER(S).
  - 1.3. All the officials of the WBSSEDCL will report the appropriate Government office any attempted or completed breaches of the above commitments as well as any substantial suspicion of such a breach.
2. In case any such preceding misconduct on the part of such official(s) is reported by the BIDDER/SUPPLIER to the WBSSEDCL with the full and verifiable facts and the same is prima facie found to be correct by the WBSSEDCL, necessary disciplinary proceedings, or any other action as deemed fit, including criminal proceedings may be initiated by the WBSSEDCL and such a person shall be debarred from further dealings related to the contract process. In such a case, while an enquiry is being conducted by the WBSSEDCL, the proceedings under the contract would not be stalled.

Commitments of BIDDERS/SUPPLIERS

3. The BIDDER/SUPPLIER commits itself to take all measures necessary to prevent corrupt practices, unfair means and illegal activities during any stage of its bid or during any pre-contract or post-contract stage in order to secure the contract or in furtherance to secure it and in particular commit itself to the following:-
  - 3.1. The will not offer, directly or through intermediaries, any bribe, gift, consideration, reward, favour, any material or immaterial benefit or other advantage, commission, fees, brokerage or inducement to any official of the WBSSEDCL, connected directly or indirectly with the bidding process, or to any person, organization or third party related to the contract in exchange for any advantage in the bidding, evaluation, contracting and implementation of the contract.
  - 3.2. The BIDDER/SUPPLIER further undertakes that it has not given, offered or promised to give, directly or indirectly any bribe, gift, consideration, reward, favour, any

material or immaterial benefit or other advantage, commission, fees, brokerage, or inducement to any official of the WBSEDCL or otherwise in procuring the Contract of forbearing to do or having done any act in relation to the obtaining or execution of the contract or any other contract with the Government for showing or forbearing to show favour or disfavor to any person in relation to the contract or any other contract with the Government.

- 3.3. The BIDDER/SUPPLIER shall disclose the name and address of agents and representatives and Indian BIDDERSs shall disclose their foreign principals or associates.
- 3.4. The BIDDER/SUPPLIER shall disclose the payments to be made by them to agents/brokers or any other intermediary, in connection with this bid/contract.
- 3.5. The BIDDER/SUPPLIER further confirms and declares to the WBSEDCL that he BIDDER/SUPPLIER is the original manufacture/Integrator/authorized government sponsored export entity of the defense stores and has not engage any individual or firm or company whether Indian or foreign to intercede, facilitate or in any way to recommend to the WBSEDCL or any of its functionaries, whether officially or unofficially to the award of the contract to the BIDDER/SUPPLIER, nor has any amount been paid. Promised or intended to be paid to any such individual, firm or company in respect of any such intercession, facilitation or recommendation.
- 3.6. The BIDDER/SUPPLIER, either while presenting the bid or during pre-contract negotiations or before signing the contract, shall disclose any payment he has made, is committed to or intends to make to officials of the WBSEDCL or their family members, agents, brokers or any other intermediaries in connection with the contract and the details of services agreed upon for such payments.
- 3.7. The BIDDER/SUPPLIER will not collude with other parties interested in the contract to impair the transparency, fairness and progress of the bidding process, bid evaluation, contracting and implementation of the contract.
- 3.8. The BIDDER/SUPPLIER will not accept any advantage in exchange for any corrupt practice, unfair means and illegal activities.
- 3.9. The BIDDER/SUPPLIER shall not use improperly, for purpose of competition or personal gain, or pass on to others, any information provided by the WBSEDCL as part of the business relationship, regarding plans, technical proposal and business details, including information contained in any electronic data carrier. The BIDDER/SUPPLIER also undertakes to exercise due and adequate care lest any such information is divulged.
- 3.10. The BIDDER/SUPPLIER commits to refrain from giving any complaint directly or through any other manner without supporting it with full and verifiable facts.
- 3.11. The BIDDER/SUPPLIER shall not instigate or cause to instigate any third person to commit any of the actions mentioned above.
- 3.12. If the BIDDER/SUPPLIER or any employee of the BIDDER/SUPPLIER or any person acting on behalf of the BIDDER/SUPPLIER, either directly or indirectly, is a relative of any of the officers of the WBSEDCL, or alternatively, if any relatives of an officer of the WBSEDCL had financial interest/stake in the

BIDDER's/SUPPLIER's firm, the same shall be disclosed by the BIDDER/SUPPLIER at the time of filling of tender.

The term 'relative' for this purpose would be as defined in Section 6 of the Companies Act 1956.

3.13. The BIDDER/SUPPLIER shall not lend to or borrow any money from or enter into any monetary dealings or transactions, directly or indirectly, with any employee of the WBSEDCL.

#### 4. Previous Transgression

4.1. The BIDDER/SUPPLIER declares that no previous transgression occurred in the last three years immediately before signing of this Integrity Pact with any other company in any country in respect of any corrupt practices envisaged hereunder or with any Public Sector Enterprise in India or any Government Department in India that could justify BIDDER's/SUPPLIER's exclusion from the tender process.

4.2. The BIDDER/SUPPLIER agrees that if it makes incorrect statement on this subject, BIDDER can be disqualified from the tender process or the contract, if already awarded, can be terminated for such reason.

#### 5. Earnest Money (Security Deposit) (If applicable as per ITB Clause 18)

5.1. While submitting commercial bid, the BIDDER/SUPPLIER deposit an amount \_\_\_\_\_ (as specified in TENDER) as Earnest Money/Security, Deposit, with the WBSEDCL through any of the following instruments:

5.1.1. Bank Draft or a Pay Order in favour of 'WBSEDCL' payable at Kolkata.

5.1.2. A confirmed guarantee by an Indian Nationalized Bank, promising payment of the guaranteed sum to the WBSEDCL on demand within three working days without any demur whatsoever and without seeking any reasons whatsoever. The demand for payment by the WBSEDCL shall be treated as conclusive proof of payment.

5.1.3. Any other mode or through any other instrument (to be specified in the TENDER.

5.2. The Earnest Money/ Security Deposit shall be valid as per terms of TENDER.

5.3. In the case of successful BIDDER/SUPPLIER, a clause would also be incorporated in the Article pertaining to Performance Bond in the procurement Contract that the provisions of Sanctions for violation shall be applicable for forfeiture of Performance Bond in case of a decision by the WBSEDCL to forfeit the same without assigning any reason for imposing sanction for violation of this Pact.

5.4. No interest shall be payable by the WBSEDCL to the BIDDER/SUPPLIER on Earnest Money/Security Deposit for the period of its currency.

#### 6. Sanctions for Violations

6.1. Any breach of the aforesaid provisions by the BIDDER/SUPPLIER or anyone employed by it or acting on its behalf (whether with or without the knowledge of the

BIDDER/SUPPLIER/SUPPLIER) shall entitle the WBSEDCL to take all or any one of the following actions, wherever required:-

- 6.1.1. To immediately call off the pre contract negotiations without assigning any reason or giving any compensation to the BIDDER/SUPPLIER. However, the proceedings with the other BIDDER(s) would continue.
  - 6.1.2. The Earnest Money Deposit (in pre-contract stage) and/or Security Deposit/Performance Bond (after the contract is signed) shall stand forfeited either fully or partially, as decided by the WBSEDCL and the WBSEDCL shall not be required to assign any reason, therefore.
  - 6.1.3. To immediately cancel the contract, if already signed, without giving any compensation to the BIDDER.
  - 6.1.4. To recover all sums already paid by the WBSEDCL, and in case of the Indian BIDDER/SUPPLIER with interest thereon at 2% higher than the prevailing Prime Lending Rate of State of India, while in case of a BIDDER/SUPPLIER from a country other than India with Interest thereon at 2% higher than the LIBOR. If any outstanding payment is due to the BIDDER from the WBSEDCL in connection with any other contract for any other stores, such outstanding payment could also be utilized to recover the aforesaid sum and interest
  - 6.1.5. To encash the advance bank guarantee and performance bond/warranty bond, if furnished by the BIDDER/SUPPLIER, in order to recover the payments, already made by the WBSEDCL, along with interest.
  - 6.1.6. To cancel all or any other contracts with the BIDDER/SUPPLIER. The BIDDER shall be liable to pay compensation for any loss or damage to the WBSEDCL resulting from such cancellation/rescission and the WBSEDCL /PRINCIPAL shall be entitled to deduct the amount so payable from the money(s) due to the BIDDER/SUPPLIER.
  - 6.1.7. To debar the BIDDER/SUPPLIER from participating in future bidding processes of the Government of India or any country listed by ADB/WBSEDCL /PRINCIPAL for a minimum period of five years, which may be further extended at the discretion of the WBSEDCL.
  - 6.1.8. To recover all sums paid in violation of this Pact by BIDDER/SUPPLIER (s) to any middlemen or agent or broken with a view to securing the contract.
  - 6.1.9. In cases where irrevocable Letters of Credit have been received in respect of any contract signed by the WBSEDCL with the BIDDER/SUPPLIER, the same shall not be opened.
  - 6.1.10. Forfeiture of performance Bond in case of a decision by the WBSEDCL to forfeit the same without assigning any reason for imposing for sanction for violation of this pact.
- 6.2. The WBSEDCL will be entitled to take all or any of the actions mentioned at para 6.1 (i) to (x) of this Pact also on the Commission by the BIDDER/SUPPLIER or anyone employed by it or acting on its behalf (whether with or without the knowledge of the BIDDER/SUPPLIER), of an offence as defined in Chapter IX of the Indian

Penal code, 1860 or Prevention of Corruption Act, 1988 or any other statute enacted for prevention of corruption.

- 6.3. The decision of the WBSEDCL to the effect that a breach of the provisions of this pact has been committed by the BIDDER/SUPPLIER shall be final and conclusive on the BIDDER/SUPPLIER. However, the BIDDER/SUPPLIER can approach the Independent Monitor(s) appointed for the purposes of this Pact.

7. deleted

- 7.1. deleted

8. Independent Monitors

- 8.1. The WBSEDCL has appointed Independent Monitors (hereinafter referred to as Monitors) for this Pact in consultation with the Central Vigilance Commission (Names and Addresses of the Monitors shall be published subsequently by WBSEDCL).
- 8.2. The task of the Monitors shall be to review independently and objectively, whether and to what extent the parties comply with the obligations under this Pact.
- 8.3. The Monitors shall not be subject to instructions by the representatives of the parties and perform their functions neutrally and independently.
- 8.4. Both the parties accept that the Monitors have the right to access all the documents relating to the project/procurement, including minutes of meetings.
- 8.5. As soon as the Monitor notices, or has reason to believe, a violation of this Pact, he will so inform the Authority designated by the WBSEDCL.
- 8.6. The BIDDER/SUPPLIER(s) accepts that the Monitors has the right to access without restriction to all project documentation of the WBSEDCL including that provided by the BIDDER/SUPPLIER. The BIDDER/SUPPLIER will also grant the Monitor, upon his request and demonstration of a valid interest, unrestricted and unconditional access to his project documentation. The same is applicable to Subcontractors. The Monitor shall be under contractual obligation to treat the information and documents of the BIDDER/SUPPLIER/Subcontractors(s) with confidentiality.
- 8.7. The BUYER will provide to the Monitors sufficient information about all meetings among the parties related to the Project provided such meetings could have an impact on the contractual relations between the parties. The parties will offer to the monitor the option to participate in such meetings.
- 8.8. The Monitor will submit a written report to the designated Authority of WBSEDCL /Secretary in the Department/ within 8 to 10 weeks from the date of reference or intimation to him by the WBSEDCL /BIDDER/SUPPLIER and, should the occasion arise, submit proposals for correcting problematic situations.

9. Facilitation of Investigation

In case of any allegation of violation of any provisions of this Pact or payment of commission, the WBSEDCL or its agencies shall be entitled to examine all the documents including



the Books of Accounts of the BIDDER/SUPPLIER and the BIDDER/SUPPLIER shall provide necessary information and documents in English and shall extend all possible help for the purpose of such examination.

10. Law and Place of Jurisdiction

This Pact is subject to Indian Law. The place of performance and jurisdiction is the seat of the WBSEDCL.

11. Other Legal Actions

The actions stipulated in this Integrity Pact are without prejudice to any other legal action that may follow in accordance with the provisions of the any extent law in force relating to any civil or criminal proceedings.

12. Validity

12.1. The validity of this Integrity Pact shall be from the date of its signing and extend up to 5 years or the complete execution of the contract to the satisfaction of both the WBSEDCL and the BIDDER/SUPPLIER, including warranty period, whichever is later. In case BIDDER/SUPPLIER is unsuccessful, this Integrity Pact shall expire after six months from the date of the signing of the contract.

12.2. Should one or several provisions of this Pact turn out to be invalid; the remainder of this Pact shall remain valid. In this case, the parties will strive to come to an agreement to their original intentions.

13. The parties hereby sign this Integrity Pact at \_\_\_\_\_ on \_\_\_\_\_

Signed on .....(Insert the Date)

-----  
Signature (of Bidder’s authorized Bid Signatory)<sup>#</sup> {In full and initials}:

- Full name: {insert full name of authorized Bid Signatory }
- Title: {insert title/position of authorized Bid Signatory }
- Name of Bidder (Sole Bidder’s name or Consortium/ JV’s name, if applicable):
- Capacity: {insert the person’s capacity to sign for the Bidder }
- Address: {insert the authorized Bid Signatory’s address }
- Phone/fax: {insert the authorized Bid Signatory’s phone and fax number, if applicable }
- Email: {insert the authorized Bid Signatory’s email address }\_\_\_\_\_

<sup>#</sup>{For a joint venture, either all members shall sign or only the authorised signatory as per ITB 19.4, in which case the power of attorney to sign on behalf of all members shall be attached }

Witness

1. \_\_\_\_\_

2. \_\_\_\_\_

[WBSEDCL]  
Name of the  
Officer  
Designation  
Deptt/MINISTR  
Y/PSU

Witness

- 1. \_\_\_\_\_
- 2. \_\_\_\_\_

\* Provision of these clauses would need to be amended/deleted in line with the policy of the [WBSEDCL] in regard to involvement of Indian agents of foreign supplies.

**Form-22**

**FORMAT OF THE BANK GUARANTEE FOR ADDITIONAL PERFORMANCE SECURITY DEPOSIT**

To  
..... (Designation of Engineer-in Charge)  
..... (Office address of Engineer-in Charge)  
.....

**WHEREAS**

(Name and address of Contractor) hereafter called “the Contractor”) has undertaken in pursuance of Contract No.....  
Dated..... to execute.....(name of Contract and brief description of Works) (hereinafter called “the Contract”)

**AND WHEREAS** it has been stipulated by you in the said Contract that the Contractor shall furnish you with a Bank Guarantee by a Scheduled Commercial Bank for the sum specified therein for ‘**ADDITIONAL PERFORMANE SECURITY DEPOSIT**’ for compliance with his obligation in accordance with the Contract.

**NOW WHEREAS,** we .....(indicate the name of the bank and branch) have agreed to give the Contractor such a Bank Guarantee.

**NOW THEREFORE,** we.....(indicate the name of the bank & branch) hereby affirm that we are the Guarantor and responsible to you on behalf of the Contractor, upto a total of Rs.....(amount of guarantee)

(in words). We undertake to pay you upon your first written demand and without cavil of argument, a sum within the limits of.....  
..... ( amount of guarantee ) as aforesaid without your needing to prove or to show grounds or reasons of your demand for the sum specified therein.

We, ..... (indicate the name of the bank and branch) hereby waive the necessity of your demanding the said debt from the contractor before presenting us with the demand.

We..... ( indicate the name of bank and branch) further agree to pay to you any money so demanded notwithstanding any dispute or disputes raised by the contractor(s) in any suit or proceeding pending before any court or Tribunal.....the present absolute and unequivocal.

The payment so made by us under this bond shall be valid discharge of our liability for payment there under and the contractor(s) shall have no claim against us for making such payment.

We (indicate the name of bank and branch ) further agree that no change or addition to or other modification of the terms of the Contract or of the works to be performed there under or of any of the Contract documents which may be made between you and Contractor shall in nay way release us from any liability under the guarantee, and we hereby waive notice of any such charge, addition or modification.

We (indicate the name of the bank and branch) lastly undertake not to revoke this guarantee except with the previous consent of you in writing.

This Guarantee shall be valid upto..... It come into force with immediate effect and shall remain in force and valid for a period upto the time of completion of work under the stated contract plus claim period of Six months for the Bank Guarantee . Notwithstanding anything mentioned above our liability against this guarantee is restricted to Rs.....(Rupees.....) and unless a claim in writing is lodged with us within the validity period i.e. upto.....this guarantee all our liabilities under this guarantee shall cease to exist.

Signed and sealed this day.....of.....2024.....at

SIGNED, SEALED AND DELIVERED
For and on behalf of the BANK

By:

(Signature)
(Designation)
(Code Number)
(Address)

NOTES: (1) The bank guarantee should contain the name, designation and code number of the officer(s) signing the guarantee.

The address, telephone number and other details of the Head Office of the Bank as well as of issuing Branch should be mentioned on the covering letter of issuing Branch.

**Form 23****West Bengal State Electricity Distribution Company Limited  
Agreement for Third Party Access Security Policy of WBSEDCL**

Organization Name & Address:	Date:
First Name      Middle Name      Last Name	Department:
Designation:	
<b>Third Party Access Security Policy</b>	
<ul style="list-style-type: none"> <li>• User shall access only the appropriate physical area of the premises and appropriate information resource.</li> <li>• Users shall not access any information resources of WBSEDCL, without prior authorization of the concerned officials of WBSEDCL.</li> <li>• User shall not carry any Personal storage media like USB, Hard drives, Laptop, DVD/CDs into secured zones like Data Centre, Disaster Recovery Centre, SCADA Centers, Smart Grid Control Centre, etc.</li> <li>• Users shall not access any information resources without the presence of WBSEDCL's authorized personnel.</li> <li>• Any passwords and access privileges given shall not be disclosed to anyone inside and outside WBSEDCL's physical and logical boundaries.</li> <li>• Users shall not engage in abusive or improper use of information resources, which includes, but is not limited to, misuse of resource/ privileges, tampering with resource and unauthorized removal of resource components.</li> <li>• User shall not conduct or permit "hacking" activities. User shall not run "packet sniffers". Users shall not distribute computer viruses, Trojan horses, worms, or any other malicious software.</li> </ul>	
I hereby declare that I have understood the information security practices followed at WBSEDCL, and I shall adhere to the procedures.	
(Signature of the Bidder)	
Date:	
Name of the Bidder:	

## Form 24

### West Bengal State Electricity Distribution Company Limited

#### NON-DISCLOSURE AGREEMENT

(To be done with successful bidder in a 100/- stamp paper)

This Non-Disclosure Agreement ("Agreement") dated Date, Month, Year ("Effective Date") is entered

BETWEEN

WBSEDCL a company incorporated under the provisions of Companies Act, 1956 and having its principal place of business at ..... thereafter referred to as "....." which expression shall mean and include its executions, administrations, subsidiaries and assigns).

AND

M/s ..... a company incorporated under the provisions of Companies Act, 2013/1956 and having its principal place of business at ..... thereafter referred to as ..... which expression shall mean and include its parent, affiliates subsidiaries and assigns) WBSEDCL and collectively referred as parties.

#### **Purpose**

WBSEDCL embarked on implementing information Security Management System (ISMS) which involves disclosure of ..... application Landscapes of WBSEDCL which are presently hosted at Data Centre and Data Recovery Centre. Such information is sensitive and confidential in nature. To protect the said confidential information both the parties desire to sign this Non-Disclosure Agreement.

#### **Disclosure of Confidential Information**

Either party may disclose to the other party either orally or in any recorded medium, information comprising or relating to its/ or its subsidiaries or franchisees techniques; schematics; designs; contracts; financial information; ERP information; SAP Modules; client data; business affairs; operations; strategies; inventions; methodologies; technologies; employees; subcontractors; pricing; service proposals; methods of operations; procedures; products and / or services (Confidential Information). Confidential Information shall include all nonpublic information furnished, disclosed or transmitted regardless its source.

#### **Confidentiality**

Either party shall use the Confidential Information solely in furtherance of the actual potential business relationship between the parties. The parties shall not use the Confidential Information in any way that is directly or indirectly detrimental to the other party and shall not disclose the Confidential Information to any unauthorized third party.

Parties shall ensure that access to Confidential Information is granted only to those of its employees or agents ("Representatives") who have a demonstrated need to know such information in order to carry out the business purpose of this Agreement. Prior to disclosing any Confidential Information to such /Representatives, party shall inform them of the confidential nature of the information and their obligation to refrain from disclosure of the Confidential Information. Each party and its Representatives will take all reasonable measures to maintain the confidentiality of the Confidential Information, but in no. event less than the measures it uses for its own information of similar type. Parties and its Representatives shall not disclose to any person including, without limitation, any corporation, sovereign, partnership, limited liability company, entity or individual(i) the fact that any investigations, discussions or negotiations are taking place concerning the actual or potential business relationship between the parties, (ii) that it has requested or received Confidential information, or (iii) any of the terms, conditions or any other fact about the actual or potential business relationship.

Each party and its Representatives will immediately notify the other party of any use of disclosure of the Confidential information that is not authorized by this Agreement. Each party and its Representatives will use its best efforts to assist the other party in remedying any such unauthorized use or disclosure of the Confidential Information Either Party shall implement and follow the rules as laid down in the information Technology (Reasonable Security Practices and Procedures and Sensitive Personal Data or Information) Rules, 2011 as and where apply.

The obligations contained under the agreement will not apply to the extent that either Party can demonstrate that the Confidential information: (a) was part of the public domain at the time of disclosure or properly became party of the public domain, by publication or otherwise; (b) was rightfully acquired by Receiving Party prior to disclosure by Disclosing Party; (c) was independently developed by Receiving Party or its Representatives without reference to the Confidential information: or (d) is required to be disclosed by a government agency or by a proper court of competent jurisdiction; provided; however, that Receiving Party and its Representatives shall provide Disclosing Party prompt prior written notice of such requirement, shall consult with and assist Disclosing Party in obtaining a protective order prior to such disclosure, and shall only disclose the

portion of Confidential information which it has been advised by written opinion of counsel is legally required to be disclosed and shall use its best efforts to obtain assurance that confidential treatment will be accorded such information if the protective order is not obtained or if Disclosing Party waives disclosure of such information.

**Ownership of Material/No Warranty**

Each Party retains all rights, title and interest to its confidential information. No license under any trademark, patent or copyright, or application for same which are now or thereafter may be obtained by the other Party is either granted or implied by the disclosure of confidential information.

**Term**

This Agreement shall terminate ..... years from the Effective Date. Receiving Party's obligations with respect to confidentiality shall expire after ..... years from the date of disclosure.

**Return of Confidential information**

Upon written request of either Party, Parties and its Representatives shall promptly return to the other Party all copies of Confidential information in its possession including all copies of any analyses, compilations, studies or other documents prepared by Receiving Party or its Representatives containing or reflecting any Confidential information. Either Party shall clarify in writing that it and its Representatives have returned all such information to the other Party.

**General**

- (a) This Agreement shall be governed by and construed in accordance with the applicable laws of India.
- (b) Either Party agrees that breach of the provisions of this Agreement by any Party will cause the other Party and irreparable damage for which recovery of money damages would be made in court of law' is Kolkata inadequate. Receiving Party and its Representatives hereby irrevocably and unconditionally consent to submit to the exclusive jurisdiction of the courts of Kolkata, West Bengal for any actions, suits or proceedings arising out of a relating to this Agreement and the transactions contemplated hereby (and agree not to commence any action, suit or proceeding relating thereto except in such courts), and further agree that service of any process, summons, notice 'or document by registered mail or tracked courier service to the address set for the above shall be effective service of process for any action, suits or proceeding brought against Receiving Party and its Representatives in any such court.
- (c) Neither party may assign any of its rights or obligations under this Agreement without the prior written consent of the other party. This Agreement shall be binding upon and inure to the benefit of the parties permitted successors and assigns.
- (d) This Agreement may be amended or supplemented only by a writing that is signed by duly authorized representatives of both parties.
- (e) No terms or provision hereof will be considered waived by either party, and no breach excused by it, unless such waiver or consent is in writing signed an authorized representative of the non-breaching party. No consent to, or waiver of, a breach by a party, whether express or implied, will constituted a consent to, waiver of, or excuse of any other, different, or subsequent breach.
- (f) If any part of this Agreement is found invalid or unenforceable, that par will be amended to achieve as nearly as possible the same economic and legal effect as the original provision and the remainder of this Agreement will remain in full force.
- (g) This Agreement constituted the entire agreement between the parties relating to this subject matter and supersedes all prior or simultaneous representations, discussions, negotiations, and agreements, whether written or oral, in the instant subject matter.

IN WITNESS WHEREOF the parties have executed these presents on the day, month and year first above written.

Signed, Sealed and delivered by:  
Shri.....representing  
WBSedCL in presence of:  
Witness:  
1)

Authorized signature with designation and seal

Signed, Sealed and delivered by:  
Shri.....representing  
M/S..... in presence of:  
Witness:  
1)

Authorized signature with designation and seal

**Form -25**  
**West Bengal State Electricity Distribution Company Limited**  
**Manufacture's Authorization Form (MAF)**

Date: \_\_\_\_\_

Tender Reference No.&amp; Tender ID. \_\_\_\_\_

Dear Sir,

We \_\_\_\_\_ (OEM) who are established and reputed manufacturers of \_\_\_\_\_ (Equipment) having Factories at \_\_\_\_\_ and \_\_\_\_\_ confirms that, M/s. \_\_\_\_\_ (Name and address of Bidder herein after called as partner) wishes to participate the Bid or Project stated above and enter into agreement for the purchase and resale of \_\_\_\_\_ (OEM) Products and, Service. The Partner is entitled and authorized to the following.

- (a) Resale, and/or distribute \_\_\_\_\_ (OEM) products and/or services in India to end users within that Territory.
- (b) Bid, negotiate and conclude a contract with \_\_\_\_\_ for the above products/services manufactured or supplied by \_\_\_\_\_ (OEM).

\_\_\_\_\_ (OEM) will, within the scope of its agreement with its authorized channels, provide product warranty services and technical support for \_\_\_\_\_ (OEM) products obtained through its authorized channels for a defect liability period mentioned in the Tender document referred above, from the date of installation at \_\_\_\_\_ (Work-site name).

\_\_\_\_\_ (OEM) certify that, the equipment being sold would not be declared End of Sale (EoS) within defect liability period and that \_\_\_\_\_ (OEM) shall supply suitable substitute in case EoS of equipment. Also \_\_\_\_\_ (OEM) certifies that the products being sold would be covered under Warranty/Technical Support and technical support will be available for defect liability period from the date of installation at \_\_\_\_\_ (Work-site name).

If you need any additional information, please contact Mr./Ms. \_\_\_\_\_ at \_\_\_\_\_ (Mobile No.) of \_\_\_\_\_ (E-mail ID).

Yours faithfully,

Name of the person:  
 For and on behalf of M/s.

Designation:

Contract Details:

Date:

Place:

(Name of Original Equipment Manufacture- OM) (Seal of OEM)



**Section - 5 : Bidding Forms - Financial Part of the Bid**

*INSTRUCTIONS TO BIDDERS: The bidder must fill and submit the price schedules online as specified in BDS.*

**1. Illustration of Price schedule (Schedule No 1 to Schedule No 5): BOQ**

	<b>Head</b>	<b>UoM</b>	<b>DC</b>	<b>DR</b>
<b>Network</b>	Spine Switch	Nos.	2	
	Boarder Switch	Nos.	2	
	Fibre Leaf Switch	Nos.	7	
	Copper Leaf Switch	Nos.	3	
	DMZ Switch	Nos.	2	
	Core Router	Nos.	2	2
	SDN Fabric Manager	Nos	1	
	Network Authentication Controller	Nos.	1	1
	Management Switch	Nos.	1	1
	Security Tools	Lot	1	
	Network and Fibre Optic Cables, as required to build the new network and keep existing Network.	Lot	1	1
<b>x86 Server</b>	48 Core or Higher CPU , 800GB Memory, 4X 10/25 Network Port, 4X16/32 GBps FC port	Nos.	10	6
<b>Virtualization</b>	Virtualization / Hyper Converged Interface plus Replication and Disaster Recovery Management License from 768 Cores, with support for three years	Nos.	480	288
<b>RISC Server</b>	12 x 12 Core RISC Processor, (80 Cores Active for DC and 95 Cores Active for DR), (10.04L SAPS X2 for DC and 12.5L SAPS for DR)	Nos.	2	1
<b>Storage</b>	Usable Storage, NVMe Flash, 1M IOPS, in TB	TB	550	450
	SAN Switch with enough ports to connect all servers to both Disk and Tape Storage	Nos.	2	2
	FO cables, patch Panels, FO Patch Cords required to build the SAN and Connect the Tape Systems and Servers	Lot	1	1
<b>Backup</b>	Tape Autoloader	Nos.	1	1
	Backup Solution including required Cartridges for 3 years	Lumpsum	1	1
<b>RACK</b>	Intelligent 42U Rack having Dual Power Supply from two sources, Extendable power supply. Capability, Top Cooling Fan, Lock and Key facility.	Nos.	2	

Item Rate BoQ

Tender Inviting Authority: Chief Engineer , IT&C Cell

Name of Work: Request for Proposal for DC/DRC infrastructure upgradation under IT/IT-OT implementation at WEST BENGAL STATE ELECTRICITY DISTRIBUTION COMPANY LIMITED under Loss Reduction Part of "Revamped Reforms-Linked Results-Base d Distribution Sector Scheme" (RDSS)

Contract No: Tel (O): 033- 2319 7445, 2319 7442, Email: cell@wbsecl.in/itcell@wbsecl.in

Name of the Bidder/ Bidding Firm / Company :

PRICE SCHEDULE

(This BOQ template must not be modified/replaced by the bidder and the same should be uploaded after filling the relevant columns, else the bidder is liable to be rejected for this tender. Bidders are allowed to enter the Bidder Name and Values only )

NUMBER #	TEXT #	NUMBER #	TEXT #	TEXT #	NUMBER #	TEXT	NUMBER	NUMBER #	TEXT #
Sl. No.	Item Description	Quantity	Units	Quoted Currency in INR / Other Currency	BASIC RATE in Figures To be entered by the Bidder	SCN/SAC	GST	TOTAL AMOUNT, It will be convert in INR	TOTAL AMOUNT In Words
1	2	4	5	12	13	19	20	53	55
1.00	<b>Hardware ,Software with Licenses and Services for DC/DRC</b>								
1.11	Supply & Delivery of Spine Switch and associated accessories at DC with 3 years warranty Support Service	2	Nos.	INR				0.0000	INR Zero Only
1.12	Supply & Delivery of Boarder Switch and associated accessories at DC with 3 years warranty Support Service	2	Nos.	INR				0.0000	INR Zero Only
1.13	Supply & Delivery of Fibre Leaf Switch and associated accessories at DC with 3 years warranty Support Service	7	Nos.	INR				0.0000	INR Zero Only
1.14	Supply & Delivery of Copper Leaf Switch and associated accessories at DC with 3 years warranty Support Service	3	Nos.	INR				0.0000	INR Zero Only
1.15	Supply & Delivery of DMZ Switch and associated accessories at DC with 3 years warranty Support Service	2	Nos.	INR				0.0000	INR Zero Only
1.16	Supply & Delivery of Two Core Routers and associated accessories at each location of DC & DRC with 3 years warranty Support Service	4	Nos.	INR				0.0000	INR Zero Only
1.17	Supply & Delivery of SDN Fabric Manager and associated accessories and software at DC with 3 years ATS Support	1	Nos.	INR				0.0000	INR Zero Only
1.18	Supply & Delivery of One no Network Authentication Controller and associated accessories at each location of DC & DRC with 3 years warranty Support Service	2	Nos.	INR				0.0000	INR Zero Only
1.19	Supply & Delivery of One no Management Switch and associated accessories at each location of DC & DRC with 3 years warranty Support Service	2	Nos.	INR				0.0000	INR Zero Only
1.20	Supply & Delivery of One no Security Tools for all locations covering DC, DRC & site offices with 3 years ATS support	1	Lot.	INR				0.0000	INR Zero Only
1.21	Supply & Delivery of Network and Fibre Optic Cables, as required to build the new 10G network at DC and maintain existing Network at DRC with 3 years support service	2	Lot.	INR				0.0000	INR Zero Only
1.22	Supply & Delivery of x86 servers comprising 48 Core or Higher CPU , 800GB Memory or higher, 4X 10/25 Network Port, 4X16/32 GBps FC port (10 nos at DC & 6 nos. at DRC) with 3 years warranty Support Service	16	Nos.	INR				0.0000	INR Zero Only
1.23	Supply & Delivery of Enterprise or higher level Virtualization / Hyper Converged Interface plus Replication and Disaster Recovery Management License for 768 Cores, with 3 years ATS support	768	Nos.	INR				0.0000	INR Zero Only
1.24	Supply & Delivery of 12 x 12 Core RISC Processor, (80 Cores Active for DC and 95 Cores Active for DR), (6.2 L SAPS X2 for DC and 7.4 L SAPS for DR) with 3 years warranty Support Service	3	Nos.	INR				0.0000	INR Zero Only
1.25	Supply & Delivery of Storage, NVMe Flash, 1M IOPS, in TB (550 TB usable at DC and 450 TB usable at DRC ) with 3 years warranty Support Service	1000	TB	INR				0.0000	INR Zero Only
1.26	Supply & Delivery of SAN Switch with enough ports to connect all servers to both Disk and Tape Storage at DC & DRC with 3 years warranty Support Service	4	Nos.	INR				0.0000	INR Zero Only
1.27	Supply & Delivery of Tape Autoloader (with minimum 5 drives each and 40 cartridge slot in each) at DC & DRC with 3 years warranty Support Service	2	Nos.	INR				0.0000	INR Zero Only
1.28	Backup Solution including required Cartridges for 3 years at DC & DRC	2	LS	INR				0.0000	INR Zero Only
1.29	Supply & Delivery of Intelligent 42U Rack having Dual Power Supply from two sources, Extendable power supply, Capability, Top Cooling Fan, Lock and Key facility at DC with 3 years warranty Support Service.	2	Nos.	INR				0.0000	INR Zero Only
1.30	Design,Installation , configuration, migration , testing commissioning and Training of entire systems ( Network/ Server/Storage) at DC	1	LS	INR				0.0000	INR Zero Only
1.31	Design,Installation , configuration, migration , testing commissioning and Training of entire systems ( Network/ Server/Storage) at DRC	1	LS	INR				0.0000	INR Zero Only
1.32	Buy back price for all EOS/EOL products as per RFP	1	LS	INR				0.0000	INR Zero Only
<b>Total in Figures</b>								<b>0.0000</b>	Zero Only

**NOT TO BE QUOTED HERE**

# **Part II**

## **Section-VI**

# Contents

- 6.1 Scope of Work for Implementation Agencies ..... 4
  - 6.1.1 Project Overview ..... 4
  - 6.1.2 Project Objectives ..... 5
  - 6.1.3 Procurement approach for the solution components ..... 5
- 6.2 IT System Design Consideration ..... 6
  - 6.2.1 Documentation..... 8
  - 6.2.2 Indicative High-Level architecture. .... 8
  - 6.2.3 CEA Guideline for (Cyber Security in Power Sector) ..... 11
- 6.3 Indicative Component of Upgraded Infrastructure. .... 13
  - 6.3.1 List of Current hardware in the DC and the DRC..... 13
  - 6.3.2 List of Current Hardware to be considered for Buy Back..... 13
  - 6.3.3 List of Current Applications running ..... 13
  - 6.3.4 Proposed Minimum Supply Requirement for upgrade. .... 14
- 6.4 Installation and Commissioning ..... 58
  - 6.4.1 Functional Requirements for a Software Defined Network with Spine Leaf Architecture Upgrade from 1G to 10G at DC and Conventional 1G Network setup at DRC.  
59
  - 6.4.2 Functional Requirements of a Virtualized Server and Storage Setup..... 64
  - 6.4.3 Functional Requirements of Backup Upgrade ..... 65
  - 6.4.4 Functional Requirements of RISC/EPIC Server Upgrade. .... 66
- 6.5 Migration of existing applications and services..... 69
  - 6.5.1 Migration of Network..... 70
  - 6.5.2 Migration of Applications to Virtual Server ..... 70
  - 6.5.3 Migration of Storage Data to New Storage..... 70
  - 6.5.4 Backup Solution Migration and DC and DRC replication..... 71
  - 6.5.5 RISC Server Migration to RISC/EPIC Servers. .... 73
  - 6.5.6 Post Migration Check..... 77
  - 6.5.7 User Acceptance Test and Final Acceptance Test..... 78
  - 6.5.8 Go Live..... 78
  - 6.6.1 Execution Period / Project Timeline ..... 82
  - 6.6.2 SLA during Maintenance Period. .... 82
  - 6.6.3 Penalties during Implementation and maintenance..... 83

6.6.3.1	Penalty For Delay in Project Implementation .....	83
6.7	Tasks and Deliverables:.....	84
6.7.1	Assessment and Inventory: .....	84
6.7.2	Design and Planning:.....	84
6.7.3	Supply and Installation: .....	85
6.7.4	Delivery Conditions: .....	85
6.7.5	Data Migration and Testing:.....	85
6.7.6	Testing and Quality Assurance: .....	87
6.7.7	Training .....	88
6.7.8	Secure Data Disposal for the buyback list of assets and Compliance:.....	90
6.7.9	Unspecified Essential Work: .....	91
6.7.10	Specifications of Onsite Resources .....	92
6.7.11	Project Management.....	92
	Project Implementation Plan would cover the following:.....	92
	Key Personnel.....	93
	Progress Report .....	93
	Transmittals.....	93
	Review Meeting .....	93
	Document Review and Approval Rights .....	94
	Document Requirements .....	94

## 6.1 Scope of Work for Implementation Agencies

Under the Scope of work WBSEDCL is looking for an AI to perform the Hardware refresh at DC- DRC and migration of application from existing infrastructure to new Infrastructure. The Scope of work can be categorized into the following parts:

1. Hardware refresh and upgradation of existing hardware from 1G to 10G at DC-DRC.
2. Migration of existing applications on existing infrastructure at DC-DRC to the new Hardware procured under this RFP.
3. Providing maintenance for Hardware and applications for a period of 5Years from the date of Go-live on new Infrastructure.
4. The solution should comprise of AMC and ATS services for all Hardware, software and Application Warranty support for 3 years.
5. The IA has to dispose the existing hardware as per the standard e-waste disposal procedure defined by the Central pollution control board.

Scope of Work (SOW) is defined in line with the concept of building a private Cloud Like infrastructure for WBSEDCL. For this, the existing end of support hardware is to be phased out. The new set of hardware to be procured must be installed in a virtualized environment having an internal network speed of 10G or more.

Furthermore, the entire setup is to be maintained during the warranty period of three years post Go live of the solutions. The hardware procured under this RFP should not reach End of support (EOS) for minimum 6 Years from the date of installation of the hardware. Any procured hardware reaching EOS before 6 years should be replaced by the Bidder.

All the newly procured hardware & Software Comprehensive Annual Maintenance Contract, Annual Technical Support for the licenses of Operating Systems and application software with the OEM are to be maintained by the implementing agency. Upgrade of Server, Storage and Networking along with migration of applications will be carried out on a CAPEX basis.

The Bidder should be responsible for buying back the end of Life hardware after securely disposing of WBSEDCL Data as per the standard e-waste management procedure.

Annexures containing DC and DRC asset details will be provided to all bidders participating in the bid. They need to email to the specified email ID as mentioned in this document from their company domain ID. It will be provided to them.

Breakdown of the Scope of Work (SOW) for consolidating and upgrading the existing IT Infrastructure under the Buyback Policy shall be as follows:

### 6.1.1 Project Overview

The project involves replacing the current End of Support IT Infrastructure . This includes managing the facility for the next three years as warranty. Details of existing IT Infra (H/W & S/W) are attached as Annexure A.

Services and applications running of the current hardware must be migrated to newly procured system by the Implementing Agency (IA) such that no new additional licenses are required as of now.

The IT system architecture should allow high availability, horizontal and vertical scalability and integration compatibility of current and future systems that may need to interact with the core application stack. It

should be ensured that the IT Infra deployed under the current scope can be integrated with core business applications. Under no circumstances WBSEDCL would procure new licenses for its core business. However, there must be scalability provisions built into the upgraded hardware.

Sizing of the IT Infra at the data center is done considering the existing IT Infra setup as base and year on year growth for the next five years accommodating/integrating any future IT systems like ERP, AMR, AMI-Smart Metering, SCADA/DMS and utility initiatives, etc. Server Sizing is done considering a virtualized environment that would accommodate all the current applications and more applications in future. Storage is sized for the current data size and must be scalable for the next five years for a growth rate of 15% data volume year on year. All solution that are to be considered must be capable of Scaling up and Out for the next eight years.

New solutions need to be provided for backup, virtualization and/or containerization.

### **6.1.2 Project Objectives**

The objective is to provide logically unified and shared infrastructure flexible enough to rapidly respond to infrastructure requirements and accommodate future technology enhancements, distributed applications, database applications running on bare metal, and virtualized applications running in hypervisor environments, that are available on demand all impose different demands on infrastructure.

**Network Speed Enhancement:** WBSEDCL Internal Network speed is to be enhanced to at least 10G.

**Software Defined Network:** Movement towards a fault tolerant SD Network.

**Virtualization:** The Compute and Storage must be used to build a Virtualized environment such that all current and future applications will be virtual cloud like infrastructure within WBSEDCL premises.

**Roadmap to SAP S/4 HANA:** WBSEDCL is moving towards SAP S/4 HANA in future. The upgraded compute system must be compliant to SAP S/4 HANA

**Support for three years after Go Live:** Go Live will be the start day of support. IA will arrange to supply all materials, complete the installation, integration, migration, and the subsequent acceptance test criteria to obtain the Go Liv. Support will consist of three years of warranty comprising, all spares, services, and licenses.

**Buyback Policy Compliance:** Ensure adherence to the outlined guidelines and policies regarding equipment buyback.

**Security and Compliance:** Ensure all security policies of WBSEDCL and that of the Cyber Security Guidelines are followed during the entire project span. Additional Tools to keep WBSEDCL compliant with the latest Cyber security Guideline must be supplied.

### **6.1.3 Procurement approach for the solution components**

The Scope of Work for this upgrade/revamp will be divided into four actionable.

- i. Submission of Documentation and Approval.**
- ii. Supply of Goods.**
- iii. Installation, Commissioning, and integration.**
- iv. Migration of older system to new system and its subsequent Acceptance after completion of Stabilization Period.**
- v. Support Service post migration and Go Live.**

The payment will be released upon supply, installation, commissioning, integration, migration, acceptance tests, stabilization period and warranty phase.

**Hardware:** Network Device, Compute Device, Storage System and Backup System

**Software:** Software Defined Network, Virtualization software, Management Software for Virtualization and automation, Backup Solution.

## 6.2 IT System Design Consideration

The Implementation Agency (IA) will be expected to bring all the installation equipment's and tools required for the installation of the system. The IA shall install, integrate, and commission the active network equipment as well as passive network components as per the approved deployment design. All the work shall be done in a conscientious manner as per the OEM guidelines and best industry practices. The system shall be subjected to inspection at the milestone stages. Local regulation/codes shall always be followed. The IA and its OEM resources shall follow all Safety Regulations and practices. The IA shall not cause any damage to the existing server farm and property at the DC and DRC and will perform restoration if any damage occurs.

The IA must establish a centralized IT environment within the DC and the DR that will,

- i. Enhance the data transfer speed to a minimum of 10G from the current 1G in DC,
- ii. Implement a Software Defined Network that would not have a single point of failure and be manageable from the NOC at DC and Conventional 1 G network at DRC with taking some devices (which equipment are within OEM support and running) from DC and some newly procured network devices. Carrying securely and installation of the devices from DC to DRC or vice versa will be responsibility of IA(implementation agency).
- iii. The implemented SDN devices must be able to accommodate the future change of devices within the DC and the DRC.
- iv. Establish a Spine Leaf Architecture for the upgraded Network.
- v. Accommodate all existing applications running in the DC Servers into a compact virtualized environment. It must be scalable horizontally and vertically for future applications for the entire support period.
- vi. Accommodate all the current data storage into Scalable Storage environment. It must be scalable horizontally and vertically for the entire support period.
- vii. Have a back Up system and software capable of a backup for the entire DC and DR landscape.
- viii. Implementation Agency is responsible for Supply, Install, Configure, Migrate, Test, and Maintain the entire solution for a period of 5 years post Go-Live. The Implementation Agency should propose only one solution that is in accordance with the RFP specifications.
- ix. The existing infrastructure assets that are still under use and will not be replaced by the current upgrade is to be compatible with the upgraded solution. The assets and services to be retained will be listed in Annexure A (Master List of Asset)
- x. Extend support to WBSEDCL 24 X 7 with onsite resource. The entire implementation service will have to be carried out with onsite resource in the DC and the DRC. Escalation matrix to this effect for all the participating OEM must be provided to WBSEDCL by the IA. In case, L3 or higher SME support is required for any critical problem/s, IA should arrange such support and WBSEDCL, at its sole discretion, will approve of such support till the resolution of the issue. However, the SLA for resolution will still be applied as per attached SLA
- xi. The IA will provide a dedicated onsite Project Manager to carry out the daily project management tasks and capacity planning for the entire project period till the Go Live and stabilization period.
- xii. Subject Matter Experts for the below competencies as per the CV of SME is to be posted on site for the entire duration of the project in addition to other resources that are required to successfully complete the project as per defined timeline till the Go Live.
  - a. Network and Security.
  - b. Virtualization and Cloud
  - c. Server, Storage, and migration.
  - d. Project Management



- xiii. IA will arrange firmware updates and upgrades from OEM, and periodic system health check-up to ensure the system is up and running optimally for the entire period of support.
- xiv. The Go-Live shall be considered after successful integration, commissioning, and migration of the IT Infrastructure to the entire satisfaction of WBSEDCL.
- xv. The duration of the Support contract will be three years after Go Live. The IA will be required to provide an infrastructure which is scalable and provides for next-generation latest technologies like virtualization, unified management etc. The IA is free to add any additional components that are deemed necessary for providing the overall solution. The IA should also consider the following while proposing the solution.
- xvi. The IA should ensure that all the peripherals, accessories, sub-components required for the functionality and completeness of the solution, including but not limited to the devices, equipment, accessories, software, licenses, tools, etc. should also be provisioned according to the requirements of the solution.
- xvii. WBSEDCL will not be responsible if the Implementation Agency has not provisioned for any components, subcomponents, assemblies, sub-assemblies as part of bill of material in the bid response. The Implementation Agency will have to provision to meet the solution requirements, at no additional cost and time implications to WBSEDCL.
- xviii. The Implementation Agency should ensure there is a comprehensive support arrangement for the entire period of engagement (including any extension) after Go-Live with all the OEM for respective IT components.
- xix. All Software, Licenses, Operating Systems and Applications must be genuine and under the sole ownership of WBSEDCL. IA will be solely responsible for any litigation arising out of issues for non-genuine software.
- xx. Help Desk Services during support period: SLA Based Support through Help Desk/telephone/specific E-mail/ personal visit. All the service-related calls will be logged by WBSEDCL/bidder/SI or FMS Vendor at WBSEDCL owned Service Desk or other ITSM tools used by WBSEDCL. Bidder will have to use the same call logging tool (Service Desk) for updating the status of the calls. IA shall access WBSEDCL helpdesk from within the WBSEDCL network. No outside access shall be granted/ allowed for integration/ticket logging. Downtime calculation report will be generated from UIM (Unified infrastructure management)/ eHealth/ Spectrum software which are installed at DC & DRC. The same ITSM tools or OEM tools may be used for logical monitoring of all the DC/DRC Hardware parallelly with physical monitoring at DC & DRC site.
- xxi. The CA Service Desk/UIM shall undertake the following activities:
  - Log issues / complaints related to IT infrastructure at the Data Centre / Disaster Recovery Centre as per BOQ under the scope of work and issue an ID number against the issue / complaint.
  - Assign severity level to each issue / complaint.
  - Track and analyze each issue / complaint to resolution.
  - If necessary, the issues / complaints will be Escalated by WBSEDCL as per the escalation matrix defined by the IA.
  - Provide feedback to the callers.
  - Creation of knowledge base on frequently asked questions to aid the users of the IT infrastructure.
  - The IA should submit monthly status report for the service calls generated in that month including previous pending calls indicating the actions taken.
  - Preparing/following Dashboard (MIS Report for availability/uptime report in CA UIM) on Quarterly basis.
  - SMS Alert to concern WBSEDCL Officers and IA for the following activities:
    - a. Logging Calls
    - b. First Response
    - c. Resolution

### **6.2.1 Documentation**

The existing asset details is available in Annexure A and the assets that are to be retained are marked in the Annexure. The IA after the LoA, must take a note of all the assets in the DC and the DRC. Accordingly, they must prepare a final documentation on:

- i. A Comprehensive Inventory of all the current Compute servers, Storage devices, Networking equipment and all other critical hardware within the DC and the DRC along with specifications, configurations and marking all the devices that are being replaced as per the Upgrade Plan.
- ii. The document must contain the current and future VLAN configuration, IP Addresses, and other details.
- iii. A SLD of the current architecture along with the upgraded architecture.
- iv. List of all software and applications currently running in the DC with details of the Versions, Licenses, Dependencies, and Integration points.
- v. A Document on Storage systems, their logical mappings to servers and applications, RAID Setups.
- vi. A list of Critical Data and a plan for their backup and migration during the project.
- vii. A plan for at least 100% betterment on current CPU utilization, Memory Usage, Network traffic and storage IOPS. Document must contain both current and upgraded metrics.
- viii. Steps to ensure all the current Security compliances are maintained and additional Security compliance with respect to private Cloud, Virtualization are added. All network devices supplied must be MTCTE compliant.
- ix. A risk assessment and a Business Continuity Plan for each phase of migration, described in the next section. Any downtime would require a special approval from WBSEDCL. IA must raise Downtime Request to WBSEDCL with due justification.
- x. A Change Management Plan involving a communication strategy for all stake holders.
- xi. A Manufacturer's Authorization Form to be attached by the Implementation Agency for all the hardware supplied by them which would ensure.
- xii. A 3-level escalation matrix for all the OEM and turnaround time of response with their email id and mobile number. A 4-level escalation matrix of the IA must also to be submitted.
- xiii. A Timeline and Project Plan outlining the tasks, milestones, resources to be used for each task in the SOW, from documentation, supply, installation, migration, UAT and Go Live.
- xiv. A support plan, post Go Live, including support from all participating OEM. This plan must be followed and back-to-back from OEM will be verified by WBSEDCL before giving approval for Go Live.
- xv. A Handover-takeover plan needs to be listed, necessary training to be given to WBSEDCL, its FMS team and its delegates.

Post the submission of the above documents, WBSEDCL would verify each one of the documents mentioned above and provide their individual approval for supply of the upgrade assets.

### **6.2.2 Indicative High-Level architecture.**

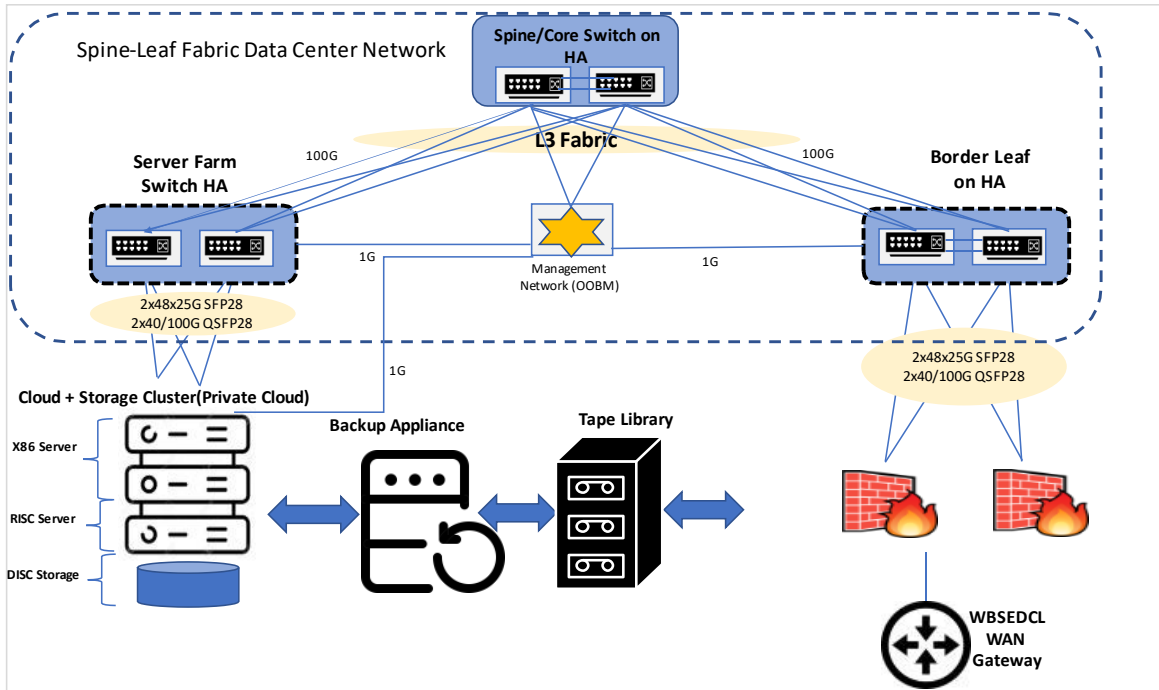

### 6.2.2.1 Drawing of the present network Architecture

Attached herewith is the current Network SLD of WBSEDCL Data Center at Rajarhat and Disaster Recovery Center at Berhampur. Details of Assets are provided in the Asset List.

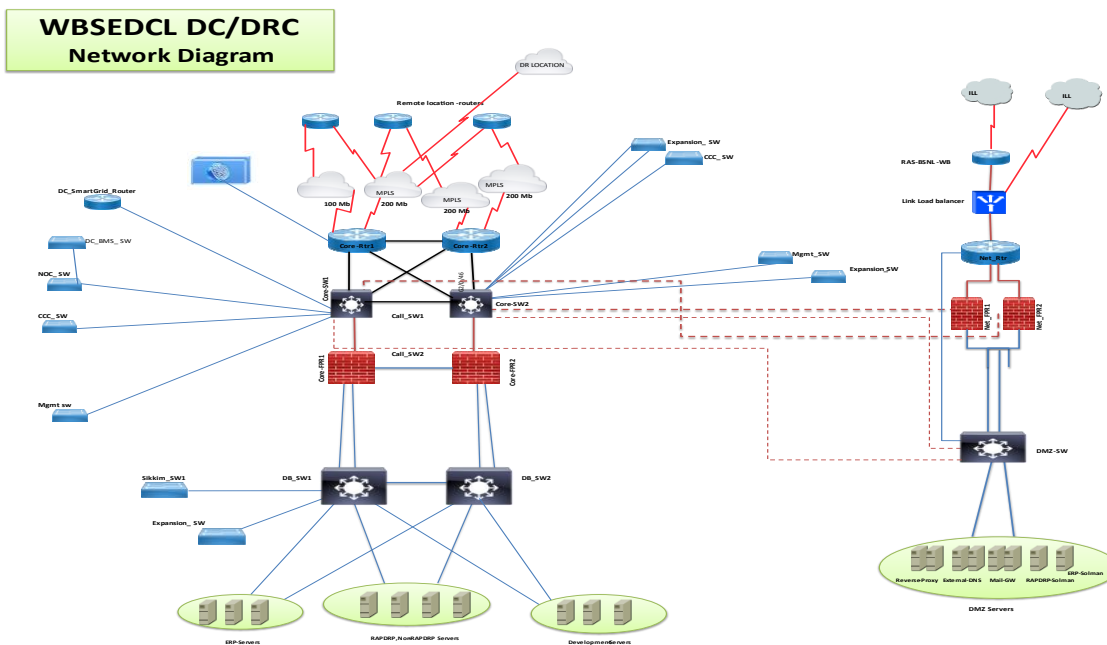

### 6.2.2.2 Drawing of the Indicative upgraded Network.

Implementation Agency must build and submit a final network diagram before supply.

## (HIGH LEVEL NETWORK SCHEMATIC DC)

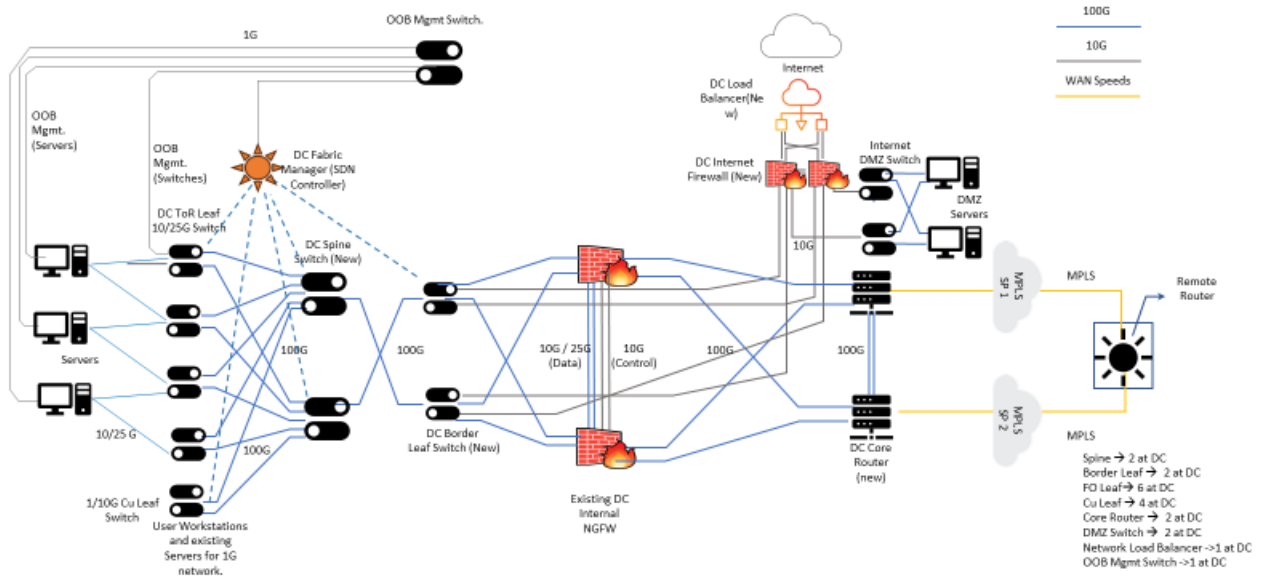

The upgraded 10G DC network connected with the existing 1G DC Network.

## (HIGH LEVEL NETWORK SCHEMATIC DRC)

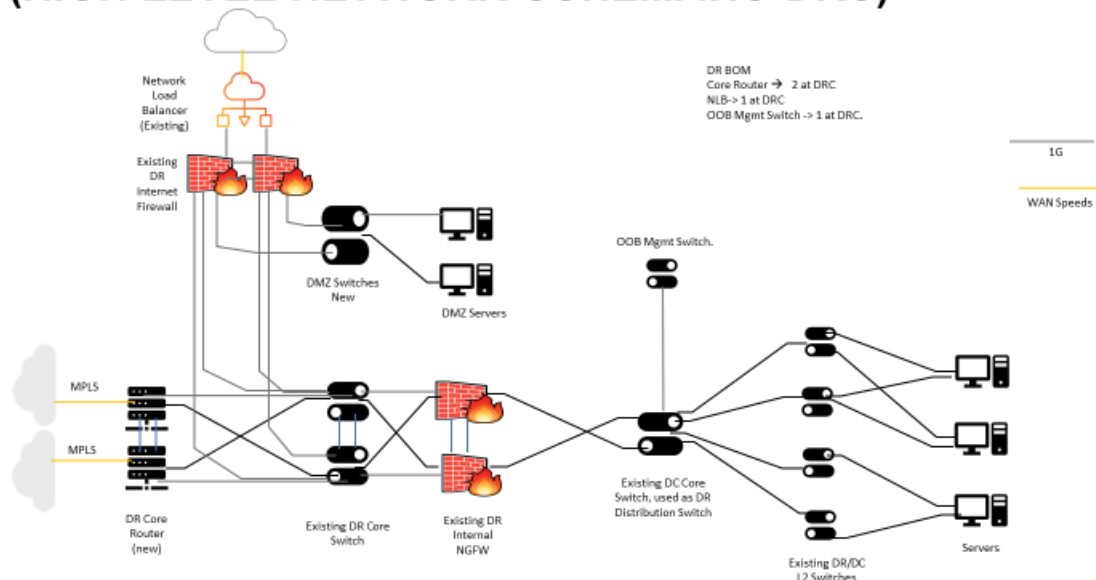

The DRC network would not be upgraded to SDN and would continue to be in the conventional Network System connected with the existing 1G DRC Network.

### 6.2.3 CEA Guideline for (Cyber Security in Power Sector)

Cyber Resilience is a measure of preparedness, the ability to respond to any cyber-attack and to recover and resume critical business operation during/after a cyber-attack by any Responsible Entity. The Mandatory Requirements (MRs) detailed in the Guidelines includes measures, tools and processes intended to prevent cyber-attacks and improve cyber resilience, should be holistically built in by Responsible Entities in their cyber security framework as well as well as cyber security policy.

#### 6.2.3.1 Objective

The objective of the CEA (Cyber Security in Power Sector) Guideline, 2022 is the preservation of:

- (a) Confidentiality: Preventing the unauthorized access to information.
- (b) Integrity: Preventing the unauthorized modification or theft of information.
- (c) Availability: Preventing the denial of service and ensuring authorized access to information.
- (d) Non-repudiation or accountability: Preventing the denial of an action that took place or the claim of an action that did not take place.

3.1 Within the text of these Guideline, '**Responsible Entity**' shall mean all:

- a) Transmission Utilities,
- b) Load dispatch centers (State, Regional and National),
- c) Generation utilities (Hydro, Thermal, Nuclear, RE),
- d) Distribution Utilities e) Generation Aggregators,
- f) Trading Exchanges,
- g) Regional Power Committees, and
- h) Regulatory Commissions.

#### 6.2.3.2 Applicability:

The Responsible Entity as well as Service Providers, Suppliers/Vendors, Service Providers, Software Designers engaged in the Indian Power Supply System shall be subjected to CEA (Cyber Security in Power Sector) Guideline, 2021. Mandatory Requirements shall be read in conjunction with the provisions of IT Act 2000 and Amendments thereof and Cyber Security Audit mandated by CERT-In.

#### 6.2.3.3 Scope

##### Control Systems, System Operation and Operation Management

- Grid Control and Management Systems,
- Power Plant Control Systems,
- Central Systems used to monitor and control of distributed generation and loads e.g., virtual power plants, storage management, central control rooms for hydroelectric plants, photovoltaic/wind power installations,
- Systems for fault management and work force management,
- Metering and measurement management systems,
- Data archiving systems
- Parameterization, configuration, and programming systems,

- Supporting systems required for operation of the above-mentioned systems,
- 

**Communication System**

- Routers switches and firewalls,
- Communication technology-related network components,
- Wireless digital systems.

**Secondary, Automation and tele control technologies**

- Control and Automation components,
- Control and field devices,
- Tele control devices,
- Programmable logic controllers/ Remote Terminal Units, including digital sensor and actuators elements,
- Protection devices,
- Safety components,
- Digital measurement and metering installations,
- Synchronization devices,
- Excitation Systems,

**6.2.3.4 Standard**

Reference	Description
ISO/IEC 15408	Common Criteria Certification Standard
ISO/IEC 17011	General requirements for accreditation bodies
ISO/IEC 17025	General requirements for the competence of testing and calibration laboratories
ISO/IEC 21827	Systems Security Engineering - Capability Maturity Model (SSE-CMM)
ISO/IEC 24748-1	Systems and software engineering — Life cycle management — Part 1: Guidelines for life cycle management.
ISO 27001/2	Information Security Management
ISO / IEC 27019	

**conformity assessment bodies**

<i>ISO/IEC24748-1</i>	Systems and software engineering — Life cycle management — Part 1: Guidelines for life cycle management.
ISO 27001/2	Information Security Management
ISO / IEC 27019	Information technology — Security techniques — Information security controls for the energy utility industry
ISO/IEC 61508	Functional Safety of Electrical / Electronic / Programmable Electronic Safety-related Systems
IEC 61850	Communication networks and systems for power utility automation

IEC 62351  
Communications  
IEC 62443  
IS 16335

Standards for Securing Power System  
Cyber Security for Industrial Control Systems  
Power Control Systems – Security Requirements

NERC CIP 002-014 Critical Infrastructure Protection Standards for Bulk Electric Providers

*Mandatory Requirements have been serially numbered as R.n under each Guideline which shall be monitored, measured and audited for compliances. The Responsible Entity shall be liable for penalty in case of non-compliances of Requirements to be latter classified as High and Medium. At present the monitoring mechanism and provisions for levy of penalty has been not covered in*

*these Guidelines, but the same shall be added in subsequent reviews of these Guidelines. This has been done to give time to the Responsible Entities to establish system and mechanism for adopting these Guidelines and build human resource capability to meet the requirements and for attaining maturity in ensuring the cyber security of their Cyber Systems.*

### **6.3 Indicative Component of Upgraded Infrastructure.**

#### **6.3.1 List of Current hardware in the DC and the DRC**

A detailed list of all Assets in the DC and DRC are provided in the ANNEXURE A tentative list of Asset

Assets those are marked as to be removed are to be considered for Buy Back items.

Assets those are marked as to be retained are to be kept as it is in the 1G network that needs to be connected in the upgraded network in DC.

Assets those are of 10G already are to be enabled for 10G and connected to the 10G Network.

#### **6.3.2 List of Current Hardware to be considered for Buy Back.**

All assets in the above list in ANNEXURE A tentative list of Asset having an Y in the to be replaced are to be considered for replacement. The remaining assets are to be retained in the DC and the DRC. The Assets that are to be replaced are to be considered for the buy back. A detailed list of actionable is given in this section 6.7.8 below. A Final list is to be prepared for the list of assets to be taken back as a part of this upgrade project after secure disposal of important WBSEDCL data and configurations. A buy Back price is to be offered during the bidding process itself, based on the Asset List. The final offer price post deduction of this price will be considered in the Price bid.

#### **6.3.3 List of Current Applications running**

Applications are running in two platforms in WBSEDCL DC and DRC. A detailed list is given below separately for the x86 Platform and the RISC platforms.

### 6.3.3.1 Applications running in the x86 Platform.

ANNEXURE B list all the existing applications running. Marked in it are applications that would be migrated to the Virtualized On Premises Cloud Platform.

### 6.3.3.2 List of Applications running in RISC server.

Annexure C lists all the existing application running in the RISC platform. The selected DB and the CI instance running in the Power8 and Power7 Platform are to be migrated to the newly procured RISC/EPIC server and the rest of the instances are to be migrated to the current Power 8 server. A feasibility study is to be conducted by the IA for the same and any hardware, software required to make that happen is to be supplied by the IA.

### 6.3.4 Proposed Minimum Supply Requirement for upgrade.

Noted herein are the list of minimum hardware and Software assets that needs to be supplied to the DC and the DR. The Bidder must add any further hardware that would be required to ensure proper functioning of the DC and DRC. All devices supplied must be Rack Enabled. The number of assets is to be in line with the Price Schedule.

The quantity of numbers of any quoted item as incorporated in the RFP are provisional, which may vary up to +/- 25% of the ordered quantity during course of execution of the contract as per actual requirement. WBSEDCL shall communicate such variations of quantity to the successful Bidder in writing. The unit price to be quoted by the Bidder and incorporated in the order would remain valid for such variation of quantity. The variation in quantity shall be communicated by WBSEDCL to the successful Bidder prior to Go Live.

	Head	UoM	DC	DR
<b>Network</b>	Spine Switch	Nos.	2	
	Boarder Switch	Nos.	2	
	Fibre Leaf Switch	Nos.	7	
	Copper Leaf Switch	Nos.	3	
	DMZ Switch	Nos.	2	
	Core Router	Nos.	2	2
	SDN Fabric Manager	Nos	1	
	Network Authentication Controller	Nos.	1	1
	Management Switch	Nos.	1	1
	Security Tools	Lot	1	
	Network and Fibre Optic Cables, as required to build the new network and keep existing Network.	Lot	1	1
<b>x86 Server</b>	48 Core or Higher CPU , 800GB Memory, 4X 10/25 Network Port, 4X16/32 GBps FC port	Nos.	10	6
<b>Virtualization</b>	Virtualization / Hyper Converged Interface plus Replication and Disaster Recovery Management License from 768 Cores, with support for three years	Nos.	480	288
<b>RISC Server</b>	12 x 12 Core RISC Processor, (80 Cores Active for DC and 95 Cores Active for DR), (10.04L SAPS X2 for DC and 12.5L SAPS for DR)	Nos.	2	1
<b>Storage</b>	Usable Storage, NVMe Flash, 1M IOPS, in TB	TB	550	450



	SAN Switch with enough ports to connect all servers to both Disk and Tape Storage	Nos.	2	2
	FO cables, patch Panels, FO Patch Cords required to build the SAN and Connect the Tape Systems and Servers	Lot	1	1
<b>Backup</b>	Tape Autoloader	Nos.	1	1
	Backup Solution including required Cartridges for 3 years	Lumpsum	1	1
<b>RACK</b>	Intelligent 42U Rack having Dual Power Supply from two sources, Extendable power supply. Capability, Top Cooling Fan, Lock and Key facility.	Nos.	2	

### 6.3.3.1 Private cloud Setup

In all cases below both DC and DRC is to be considered. Requirements with respect to sizes are mentioned separately in the table below.

Device	Specification	Details	Compliance
Virtual Compute	Cloud Management	Offered private cloud shall allow WBSEDCL to build their self-service cloud on demand and deliver virtual machines across hybrid cloud. Offered Private cloud solution shall also allow creation of VM from Public cloud provider directly from the Private cloud console and shall be able to import the images and instance type while provisioning the VM	
		Dashboard shall clearly show the overall number of Virtual machines being managed from Private cloud.	
		Dashboard shall also provide the information about number of VMs and Systems, which are more than 95% full w.r.t capacity	
		Dashboard shall also the output of configuration check of overall installed system and shall clearly highlight the issues, if any, by clicking on them	
		Dashboard shall also show the performance and latency of top VMs and recently provisioned VMs.	
		Offered Private cloud shall list down the current version of offered system (Hardware, Management module, Hypervisor, Service Pack, Storage layer) and shall also provide the update path of next version from the GUI itself	
		Offered Private cloud shall allow the migration of the data from one datastore of a given cluster on a given system to another datastore on a different system.	
		Offered Private cloud shall allow the functionality to reset the virtual machines like Power Reset / Shutdown / Reboot / Power-off etc	
		Offered Private cloud shall allow the functionality to migrate the virtual machine from one cluster to another cluster and one datastore of one system to another datastore of another system.	
		Offered Private cloud shall allow the importing of virtual machines from System which are not actively managed by the Private cloud console.	
		Offered private cloud shall allow to create the single on premise VM provisioning policy for selecting De-duplication, encryption and quality of service. Solution shall ensure that VM provisioning	

		service shall be available either for unified file format that is compatible across all virtualization products in the market.		
		Offered private cloud shall allow creation of VM directly from the cloud console and shall be able select OS template from Content Library, VM provisioning policy for Storage operations like De-duplication, Encryption, Quality of service and Backup protection policy from a single wizard.		
Hyper Convergence Infrastructure Solution) or HCI	Platform	Offered Platform shall have complete independence for the scaling of both Compute and Storage platform. Scaling of both components shall be completely independent without any immediate disk re-balancing operation.		
	Hypervisor Support	Offered platform shall provide the simplicity of Hyper-converge from market leading Hypervisors along with required licenses as per below specifications and requirements.		
	Server Node		The proposed HCI solution should support scalability of nodes in a single cluster. Each server node should have dedicated redundant hot swap power supplies & cooling fans.	
			Offered Platform shall be supplied with at-least 10 number of Server Nodes in DC and 6 in DRC.	
			Each Server engine shall have flexibility to see and consume the entire capacity of storage layer.	
			Each Server node / engine shall be supplied with at-least: 480 Core CPU in DC and 288 CPU in DRC, 8TB or More Memory of memory in DC and 5 TB or More in DRC, 4X 10/25 Network Port or more in DC and 4 X 1/10G Network Port or more in DRC, 4X16/32 GBps FC port in DC and DRC.	
			2 x Intel Xeon-Gold 5318Y 2.1GHz or higher 48 or higher Intel-core or equivalent or Higher Processor. Each compute engine shall have at-least two number of 960 GB SSD drives for boot configured in RAID1. Offered compute node shall also support 25Gbps & 100Gbps IP ports.	
			Offered platform shall also be supplied with additional dedicated 256GB L3 cache / memory for read and write operations on each node of storage layer.	
			The HCI solution should be configured with minimum of 550 TB usable storage capacity excluding cache capacity for each of DC and 450 TB in DRC. The capacity to be configured with minimum data protection of replication factor 2 or equivalent or higher. The capacity should be absolute capacity without considering any data efficiency techniques as Data Deduplication and compression. Any other capacity required for meta data, host maintenance mode, component rebuilds etc. should be factored over and above the capacity	
		The solution should support All Flash configuration with support for 2U form factor with the addition of the latest Intel 2.1 Ghz or higher Processors or higher and 64 GB or higher DIMM capacity		
Management		Complete platform shall be managed directly from offered hypervisor management layer and shall not require multiple management tools for day-to-day operations.		
		Each compute engine shall have additional network port for remote management. Remote management shall have own dedicated flash memory.		
		Each compute engine shall have immutable silicon root of trust for ensuring that under any situation – firmware is completely tamper-proof and at any stage shall not be compromised.		

	Data Protection	Offered platform shall use all NVMe flash drives only for storage layer. All offered NVMe Flash drives on storage layer shall be configured with Hardware RAID 1 for asked usable capacity.	
		Failure of any compute engine shall not reduce the overall number of offered drives. In case vendor is not supporting this capability, then additional one node of the same configuration in terms of compute and storage shall be provided.	
	Performance	Offered platform shall have flexibility to utilize all offered drives on storage layer for a given virtual machines for both read and write operations and shall not be limited to local node allocation.	
		There shall be no performance de-gradation during critical support activities like Firmware upgrade, patch upgrade etc.	
		Offered Platform shall provide 1M IOPs and sub-millisecond Latency with 80:20 Read: write ratio and 8K Block size.	
	No Single Point of Failure	Offered platform shall be configured in no single point of failure-environment. Vendor shall design in such a way that storage layer shall provide at-least 6 nines data availability and VM availability is being maintained through the offered hypervisor clustering.	
		There shall be no performance de-gradation on storage layer due to a single component or storage node failure. Vendor shall provide the documentary proof for same.	
	CPU and Drives support	Offered platform shall have the capability to support x86 CPU various NVMe flash capacities drive within the same cluster.	
	Investment Protection	Offered platform shall non-disruptively scalable to higher generation platform within the given family without any forklift upgrade. There shall be no downtime, no data re-balancing while upgrading to next generation model.	
	Storage Integration	Offered platform shall be tightly integrated with Hypervisor and shall be certified for VOL. The platform should not need any helper software of any kind to work properly with storage volumes and shall support: a. Platform Shall support both compression and de-duplication for virtual Volumes of Storage. b. Platform Shall support Scheduled snapshot and quality of service for Storage Volumes. c. Platform shall support encryption of Storage Volumes assigned to Virtual Servers	
	Quality of service	Offered platform shall support and supplied with Quality of Services (QoS) for controlling the IOPS and MB/sec for a given datastore selectively.	
		Offered platform shall automatically do QoS in order to prevent a single workload from taking over the overall storage layer performance.	
	Thin Provisioning and Space optimization	Offered platform shall support critical global data efficiency features - inline de-duplication, inline compression, and thin provisioning without any performance degradation	
		All above data efficiency features shall be truly global and shall have capability to compare chunks across all VMs and datastores enabled / created into the platform.	
		Offered platform shall support both non-duplicated datastores as well as duplicated datastores at the same time within the platform.	
Offered Platform shall support both non-compressed as well as compressed datastores at the same time within the platform.			
Snapshot /	Offered platform shall support more than 1000 Snapshots for a		

	Point in time copy / Zero Copy Clone / Thin Clone	given datastore. Vendor shall use efficient performance technology like re-direct on write or better.	
		All created snapshots shall support global de-duplication and compression.	
		Offered platform must support multiple Snapshots or Clones or Replications sessions without any impact to performance.	
	Data Integrity and Encryption	Offered platform shall offer checksums that go beyond the T10-PI standard. The checksums will automatically detect and prevent errors resulting from lost/misplaced reads or writes that T10-PI and equivalent check summing systems cannot remediate	
		Offered platform shall be supplied with certified encryption at Granular datastore level even without using encrypted NVMe flash drives.	
	Remote Replication	Offered platform shall support Stretch cluster across locations while ensuring that dual write is being maintained at each location. Replication across locations shall be native inside the platform.	
		Offered Platform shall have ability to replicate only incremental changes between two sites (DC and DRC).	
		Offered platform shall support FAN out asynchronous replication from primary location to at-least two secondary locations for a given volume. It shall provide the flexibility to define the separate schedule for each replication relationship	
	Licenses	Vendor shall provide the license for all critical functionalities like capacity expansion, Snapshot, Thin Clone, Replication and QOS etc. for the maximum supported capacity of platform. There shall be no additional software license requirement for future capacity upgrade. Any additional license required for meeting the RFP specification shall also be offered upfront.	
	Storage Architecture	General Requirements	The HCI storage should be a scale-out distributed storage
The HCI software should pool all NVMe from all the nodes in the cluster to present a single storage resource pool to all server nodes in the cluster. There should not be any dependence on data locality			
The HCI software should pool all NVMe from all the nodes in the cluster to present a single storage cache pool across the HCI nodes.			
The HCI should support IO striping across all NVMe in the cluster for individual virtual machines to extract maximum throughput and performance from the cluster.			
The HCI solution should support scaling storage capacity and performance linearly by addition of nodes. VMs on existing nodes should get the storage performance & capacity that was scaled by the addition of new HCI nodes.			
The HCI solution should be able to present cluster wide storage performance to any single large Virtual machine.			
Present scale-out storage to compute only nodes for Seamless failover of compute-only nodes for a fully high available design of HCI			
The HCI should support connecting to external 3rd party SAN (FC, ISCSI) and NFS storage into the HCI cluster for capacity expansion and ease of migration from existng environment to HCI			
The HCI solution should support various data replication methods (RF=2 & RF=3) or equivalent for data protection. Any software license required to enable RF=2 & RF=3 should be quoted on day			

		1.	
		The HCI solution should support Inline Deduplication across all storage tiers.	
		The HCI solution should support for 1 nodes failure in entire solution	
		The Solution should support Instant space optimized point-in-time Snapshots. Should allow for taking snapshots of individual Virtual Machines to be able to revert back to an older state, if required. Any additional software and license should be provided on day 1.	
		The Solution should allow for taking clones of individual Virtual Machines for faster provisioning. Any additional software or license required should be provided on day 1.	
		The HCI storage should have integrated wizard to schedule snapshot for hourly/weekly/monthly snapshot policies. Any additional software or license should be provided on day 1.	
		The HCI solution should be able to boot bare-metal servers from iSCSI LUNs hosted onto the HCI solution	
		The HCI storage should have integrated wizard for batch clones of virtual machines and customization. Any additional software or license should be provided on day 1.	
		The proposed HCI solution must support file-level end-to-end data encryption to provide confidentiality of data at the HCI software level and without adding any overhead to the hypervisor or guest VMs. Encryption should be FIPS 140-2 compliant and should support 256-bit AES inline encryption. It should allow the coexistence of encrypted and unencrypted Virtual data stores in the same cluster. Necessary key management solution must be included in the proposal. If the proposed solution does not feature native encryption and key management solution, then the Implementation Agency can propose a proven and popular 3rd party solution for encryption and key management. Necessary licenses to support the full capacity/VMs/CPU's must be included in the proposal.	
		The proposed solution must support synchronous replication between DC and Near DC (whenever WBSEDCL decides to deploy an Active-Active disaster avoidance solution for mission-critical workloads requiring high uptime (near zero Recovery Time Objective) and no data loss (zero Recovery Point Objective). Necessary licenses required to achieve this solution must be included in the proposal to support full capacity/VMs/CPU's.	
		The solution should automatically rebalance data to maintain balanced utilization of storage across the HCI nodes. When storage capacity is scaled up or scaled out, the HCI nodes must automatically redistribute data equally across all nodes equally without migrating VMs.	
		The same storage must be OS agnostic and must be able to accommodate storage pools from Windows or Unix pool. Unix may be of any flavor available in the market.	

**6.3.3.2 Network**

Functional Specification of the Network devices upgrade.

- The IA shall provision different Network devices (Router, Firewall, Web Application firewall, Core Switch, Distribution Switches and Access Switch) for the required network infrastructure.

- The IA should provision devices compatible to support 10G or higher network.
- The IA must link the upgraded 10G network with the remaining portion of 1G network seamlessly.
- The Network should be designed with Spine-Leaf architecture.
- The IA shall without fail submit the technical compliance sheet as per the table mentioned below.
- The IA shall ensure that all the supplied hardware /software and spares/upgrades for the solution shall have a OEM support up to next 5 years from the date of commissioning of the entire Setup after Go Live.
- The IA shall ensure from the OEM that they supply the latest set of hardware and Software, and the OEM will support them for the next seven years, at least, post Go Live.
- The devices proposed should have Zero touch serviceability and should be available from day one.
- All Active Network devices must support OPENFLOW protocol.
- The devices provided at the locations shall be new and Implementation Agency shall provide and install software Updates/Patches/Versions during all the Stages up to five years post Go Live for all software components including operating systems (that of Network Equipment's), firmware, management software, security software, or any other software, which would be part of the supplies.
- Implementation Agency is required to design, supply, implement, maintain, and manage hub network devices commissioned and provide warranty, AMC and ATS services for the mentioned equipment(s) and associated management software during the tenure of contract.

A Security Tool having below features are to be added to the list supply materials. It must be duly installed, configured and handed over to WBSEDCL with adequate training to utilize its proper benefits.

Vulnerability scanning tools are software applications designed to identify and assess security vulnerabilities within networks, systems, applications, and devices. These tools automate the process of discovering potential weaknesses that could be exploited by attackers. Some common features and capabilities of vulnerability scanning tools include:

1. **Network Scanning:** Identifying devices, servers, and endpoints connected to the network and scanning them for known vulnerabilities.
2. **Port Scanning:** Detecting open ports and services on networked devices, which can help identify potential entry points for attackers.
3. **Vulnerability Assessment:** Analyzing systems and applications for known security vulnerabilities, misconfigurations, and weak security settings.
4. **Patch Management Integration:** Integrating with patch management solutions to identify missing patches and updates that could address known vulnerabilities.
5. **Compliance Checks:** Assessing systems against security standards and compliance frameworks to ensure they meet regulatory requirements.
6. **Web Application Scanning:** Identifying vulnerabilities within web applications, such as SQL injection, cross-site scripting (XSS), and insecure server configurations.

7. **Credential Scanning:** Authenticating with devices using provided credentials to perform deeper scans and identify vulnerabilities that require elevated privileges to detect.

### Hardware Specification

Device	Specification	Details	Compliance
Core Router	General Requirements	The Router should support chassis or fixed form-factor, multi-core Processor, internal redundant field replaceable power supply (from Day1). The Router Should have capabilities of seamless field upgrade/replacement (without interrupting running processes and services ).	
		Router should have a physical separation between control and data planes processor. Router should support inline hardware accelerated encryption for high-throughput IPsec	
	Hardware and Interface Requirement	Router should have minimum 8 x 1G SFP base and minimum 48 port 1G ethernet module LAN / WAN and 4 x 10G LAN / WAN Interface loaded with 2* long range module and 2* short range module	
		Router should have minimum 16GB of on-board/inbuilt DRAM/RAM for data plane + control plane processes and 32 GB storage from Day 1.	
	Performance Requirement	Router should have minimum IP forwarding throughput of 38 Gbps	
		Router should support minimum 4M IPv4 & IPv6 routes	
		No. of Firewall session: 2M	
		The router must support IKEv1, L2TP, IKEv2, GRE and IPSEC from day 1. The proposed solution should serve the GRE encryption for traffic from any location to other location on demand and also should able to create GRE tunnel.	
		The router should support 19 Gbps of IPSEC Bandwidth	
		Implementation Agency should ensure necessary encryption 8.5 Gbps throughput (IMIX, EMIX) supported by proposed device at site from day 1: (IPSEC case of SD-WAN)	
		Router should be scalable to support up to 4000 tunnels (non-SDWAN) / 8000 SD_WAN tunnel (SD-WAN)	
		Router should support VRF level segmentation with min support for 8000 VRF segments	
		Router should support IGMP v1/v2/v3 and PIM multicast routing	
Layer3 Features & Security	Router should support static Routes, OSPFv2, OSPFv3, BGP4, MBGP, BFD, Policy based		

		routing, IPv4 and IPv6 tunneling from Day 1		
		The Router should support Zone Based Firewall feature or an external appliance for the same functionality can be provided.		
		Router should Support Traffic Optimization feature built in the router operating system or an external appliance for the same functionality can be provided.		
		Shall have 802.1p class of service and marking, classification, policing and shaping.		
		Should support advanced encryption algorithms like AES-256 and AES-GCM		
		The router should be able to support Hierarchical QoS. QoS should be supported both at Physical and sub-interface level		
		Router should be able to do deep packet inspection and identify applications at layer-7 and we should be able to define QoS and access control based on application. It should be possible to identify at least 1000 common applications by Device.		
		Manageability	Router should support SSHv2, SNMPv2c, SNMPv3 and NTP	
			Routers should support AAA using RADIUS and TACACS+	
			Should have extensive support for IP SLA or equivalent and best path selection for metrics like delay, latency, jitter, packet loss to assure business-critical IP applications from Day1.	
			Router should support monitoring of network traffic with application level insight with deep packet visibility into web traffic, RTP-Based VoIP traffic.	
			Router shall conform to UL 60950 or IEC 60950 or CSA 60950 or EN 60950 Standards for Safety requirements of Information Technology Equipment.	
			Router shall conform to EN 55022 Class A/B or CISPR22 Class A/B or CE Class A/B or FCC Class A/B Standards for EMC (Electro Magnetic Compatibility) requirements.	
			Router/Router's Operating System should be tested and certified for EAL 3/NDPP or above under Common Criteria Certification	
	Router should be IPv6 Certified/IPv6 logo ready			
Network Authentication Controller	General Specifications	The Solution should provide a highly powerful and flexible attribute-based access control solution that combines authentication, authorization, and accounting (AAA); posture; profiling; and guest management services on a single platform.		
		It should allow enterprises to authenticate and authorize users and endpoints via wired, wireless, and VPN with consistent policy		



		throughout the enterprise	
		Provides complete guest lifecycle management by empowering sponsors to on-board guests.	
		Solution should be scalable enough to support at least 25000 endpoints in the network.	
		Solution should be scalable enough to support 200 Network devices.	
		Delivers customizable self service portals as well as the ability to host custom web pages to ease device and guest on-boarding, automate endpoint secure access and service provisioning, and enhance the overall end-user experience inside business-defined workflows	
		The solution should support guest users onboarding through social media login to simplify the registration process	
		The solution should support sponsor approval for guest users connecting into the network and the approval request should have control from multiple sponsor to avoid single point of failure	
		The solution should support flexible guest account approval even in absence of sponsor	
		The Solution should support complete guest lifecycle where Sponsor should be able to Extend,Suspend and reinstate guest accounts with reasons.	
		Offers comprehensive visibility of the network by automatically discovering, classifying, and controlling endpoints connected to the network to enable the appropriate services per endpoint	
		Enforces security policies by blocking, isolating, and repairing noncompliant machines in a quarantine area without requiring administrator attention	
		Offers a built-in monitoring, reporting, and troubleshooting console to assist helpdesk operators and administrators streamline operations	
		Allows you to get finer granularity while identifying devices on your network with Active Endpoint Scanning	
		The NAC solution should be able to block unauthenticated/rogue machine without giving any access to the network.	
		Augments network-based profiling by targeting specific endpoints (based on policy) for specific attribute device scans, resulting in higher accuracy and comprehensive visibility of what is on your network	
		The NAC solution should be able to control the user even before IP address is assigned. It	

		should act as a pre-admission solution	
		The NAC solution should be able to integrate with APT, NBAD and SIEM solution	
		The solution should provide full TACACS+ capability including enable password, configuration present for different NAD types, TACACS+ proxy etc.	
		Manages endpoint access to the network with the Endpoint Protection Service, which enables administrators to specify an endpoint and select an action - for example, move to a new VLAN, return to the original VLAN, or isolate the endpoint from the network entirely - all in a simple interface	
		Utilizes standard RADIUS protocol for authentication, authorization, and accounting (AAA).	
		Supports a wide range of authentication protocols, including PAP, MS-CHAP, Extensible Authentication Protocol (EAP)-MD5, Protected EAP (PEAP), EAP-Flexible Authentication via Secure Tunneling (FAST), and EAP-Transport Layer Security (TLS).	
		Offers a rules-based, attribute-driven policy model for creating flexible and business-relevant access control policies. Provides the ability to create fine-grained policies by pulling attributes from predefined dictionaries that include information about user and endpoint identity, posture validation, authentication protocols, profiling identity, or other external attribute sources. Attributes can also be created dynamically and saved for later use	
		Provides a wide range of access control mechanisms, including downloadable access control lists (dACLs), VLAN assignments, URL redirect, and Security Group Access (SGA) tagging.	
		Should have predefined device templates for a wide range of endpoints, such as IP phones, printers, IP cameras, smartphones, and tablets.	
		It should allow Administrators to create their own device templates. These templates can be used to automatically detect, classify, and associate administrative-defined identities when endpoints connect to the network. Administrators can also associate endpoint-specific authorization policies based on device type.	
		Solution must allow administrator to add exception for certain device properties in the device templates/ device profiles available in the solution to filter unintentionally picked parameters of endpoints.	

		The Solution should have capability to collect endpoint attribute data via passive network telemetry, querying the actual endpoints, or alternatively from the infrastructure via device sensors on switches.	
		The Solution should have capability to see endpoints attribute data via passive network telemetry or alternatively from the infrastructure via device sensors on switches at Core, Distribution and Access Layer.	
		Solution should allow end users to interact with a self-service portal for device on-boarding, providing a registration vehicle for all types of devices as well as automatic supplicant provisioning and certificate enrollment for standard PC and mobile computing platforms.	
		Solution should have capability to grant authenticated users with access to specific segments of the network, or specific applications and services, or both, based on authentication results.	
		Solution should have capability which allows users to add a device on a portal, where the device goes through a registration process for network access. Should allow users to mark as lost any device that you have registered in the network, and blacklist the device on the network, which prevents others from unauthorized network access when using the blacklisted device. Should have capability to reinstate a blacklisted device to its previous status in Device Portal, and regain network access without having to register the device again in the Devices Portal. Should also support removing any device in the enterprise network temporarily, then register the device for network access again later.	
		Solution should support automatic provisioning of NAC agents	
		The NAC solution should support any SAML v2 compliant solution.	
		Solution should support periodic reassessment for clients that are already successfully postured for compliance.	
		Solution should support the following endpoint checks for compliance for windows endpoints:	
		- Check operating system/service packs/hotfixes	
		- Check process, registry, file & application	
		- Check for Antivirus installation/Version/Antivirus Definition Date	
		- Check for Antispyware installation/Version/Antispyware Definition Date	

		- Check for windows update running & configuration	
		Solution should support following remediation options for windows endpoints:	
		Should support native supplicant profiles to enable users to bring their own devices into network. When the user logs in, based on the profile that you associate with that user's authorization requirements, solution should provide the necessary supplicant provisioning wizard needed to set up the user's personal device to access the network. This should be supported over Microsoft windows, Apple Mac and iOS and Android devices.	
		Must be able to differentiate policy based on device type + authentication	
		The solution should support BYOD workflow for Partner/Contractor or Employees for BYOD scenario by automatically provisioning the supplicant such that Owner & the device are authenticated based on certificate.	
		The NAC solution should be standard RADIUS server with built-in certificate authority	
		The CA server should be able to provision certificate for multiple use cases like BYOD, EAP authentication and Third Party Client and Server side authentication.	
		The solution must have internal CA server functionality with flexibility to create certificate template to be used by other network services	
		Should support authenticating IP phones and users connected behind IP phones on the same physical port.	
		Solution should have profiling capabilities integrated into the solution in order to detect headless host. The profiling features leverage the existing infrastructure for device discovery. Should support the use of attributes from the following sources or sensors:	
		* Profiling using MAC OUIs	
		* Profiling using DHCP information	
		* Profiling using RADIUS information	
		* Profiling using HTTP information	
		* Profiling using DNS information	
		* Profiling using NetFlow information	
		* Profiling using SPAN/Mirrored traffic	
		Solution should support troubleshooting authentication issues by triggering session reauthentication to follow up with an attempt to reauthenticate again.	
		The NAC solution should integrate with vulnerability scanner like Rapid7, Tenable etc. Should be a listed vendor and officially supported integration and should allow use of	

		threat intelligence to build authorization permissions based on the vulnerability scores received from these tools to enforce permissions.	
		Should support session termination with port shutdown option to block an infected host that sends a lot of traffic over the network.	
		Should support the functionality to force endpoint to reacquire IP address that do not support a supplicant or client to generate a DHCP request after a vlan change.	
		Troubleshooting & Monitoring Tools	
		Should support evaluation of the configuration of the device with the standard configuration.	
		Should support TCP dump utility & also support saving a TCP dump file.	
		Solution should support schedule reports to run and re-run at specific time or time intervals & send and receive email notifications once the reports are generated.	
		The solution must have internal CA server functionality to provision certificate for multiple use cases like BYOD, Contractor, Employee Asset etc.	
		The Solution should support complete guest lifecycle where Sponsor should be able to Extend, Suspend and reinstate guest accounts with reasons.	
		The solution should support centralized and distributed deployment options with clustering of nodes or cross-site failover for disaster recovery scenarios	
		Solution should support integration with leading helpdesk ticketing system. It should support self remediation through end user self support and automatic remediation including guided remediation, quarantine, manual remediation etc.	
		Any third party product required to achieve the functionality should be provided with the necessary enterprise version license of software/appliance and necessary hardware, database and other relevant software or hardware etc should be provided with the solution	
		Solutions must support agent, agentless and dissolvable agent method for performing endpoint profiling, base-lining, health check and prevention	
		Solution should be able to enforce Layer 4 controls right from Access to distribution to core to edge to data center to servers without the need of mirroring the traffic and maintaining end to end segmentation even when two endpoints are in same broadcast	

		domain.	
		Solution should consume license only based on active devices on the network where Devices include user endpoints (such as laptops, tablets and smartphones), non-user devices (such as printers, IP phones, security equipment, medical devices, manufacturing equipment), virtual machines, Network infrastructure devices (such as switches, routers and access points) should not consume license and If so vendor should consider these licenses exclusively and should be counted along with User/Endpoints.	
		Solution should support detecting Endpoint anomaly behavior for example - a device MAC address earlier seen on Wired Network next moment or later seen on Wireless network etc.	
		Open seating environments where the MAC addresses is not persistence, solution should be to authorize managed endpoint	
		The solution should be able to detect the IOT devices using MUD for identifying the device type and its capabilities. Manufacturer Usage Description (MUD) is an embedded software standard defined by the IETF that allows IoT Device makers to advertise device specifications, including the intended communication patterns for their device when it connects to the network.	
Spine Switch	General Requirement	The Switch should support non-blocking architecture, all proposed ports must provide wire speed line rate performance	
		Switch should support the complete STACK of IPV4 and IPV6 services.	
		All relevant licenses for all the features and scale should be quoted along with switch and all these licenses and features should be available from Day 1.	
		The Switch and Transceivers should be from the same OEM	
	Hardware and Interface Requirement	Min of 32 non-blocking interfaces populated with multimode 40/100G Transceivers from day 1	
		Switch should have console port for local management & Out of band management interface for remote management	
		Switch should have adequate power supplies for the complete system usage and for providing N+1 power supply redundancy	
		All Transceivers/ Cables should be added as per the BOQ from Day 1	
	Performance Requirement	Switch should support minimum 1000 VRF instances with route leaking functionality	
The switch should support minimum 400K			

		IPv4 Longest Prefix Match routes	
		The switch should support 30k multicast routes	
		Switch should support a minimum of 12 TBps Bandwidth	
		Device should be based on simple and intelligent shared-memory buffered architecture that simplifies the system buffer management and queuing implementation. Both the SAN switch and the Spine/Leaf switches should be from the same OEM	
		The switch proposed should have minimum 64 MB Packet Buffer	
		The switch should have capability to support 400G without any additional software or module from day 1	
	Network Virtualization Features	Switch should support VXLAN to achieve Network Virtualisation.	
		Switch should support VXLAN and EVPN symmetric IRB for supporting Spine - Leaf architecture to optimise the east - west traffic flow inside the Data Centre.	
	Layer2 Features	Switch should support minimum 90K no. of MAC addresses	
		Spanning Tree Protocol (IEEE 802.1D, 802.1W, 802.1S)	
		Switch should support VLAN Trunking (802.1q)	
		Switch should support layer 2 extension over VXLAN across all Data Centres to enable VM mobility & availability	
		Switch should support IEEE Link Aggregation and Ethernet Bonding functionality (IEEE 802.3ad) to group multiple ports for redundancy	
		The switch should support BGP EVPN Route Type 2, Type 4 and Route Type 5 for the overlay control plane	
	Layer3 Features	Switch should support static and dynamic routing	
		Switch should support segment routing and VRF route leaking functionality from day 1	
		Switch should provide multicast traffic reachable using PIM-SM, PIM-SSM and Multicast Source Discovery Protocol (MSDP)	
Switch should support Multicast routing			
Quality of Service	Switch should support 802.1P classification and marking of packet using CoS (Class of Service) and DSCP (Differentiated Services Code Point)		
	Switch should support different type of QoS features for real time traffic differential treatment using Weighted Random Early		

		Detection and Strict Priority Queuing.	
		Switch should support to trust the QoS marking and priority settings of the end points as per the defined policy	
	Security	Switch should support control plane Protection from unnecessary or DoS traffic by control plane protection policy	
		Switch should support external database for AAA using TACACS+ and RADIUS	
		Switch should support for Role Based access control (RBAC) for restricting host level network access as per policy defined	
	Manageability	Switch should support for sending logs to multiple centralized syslog servers for log monitoring and audit trail.	
		Switch should provide remote login for administration using SSHv2	
		Should support hardware telemetry without impacting performance of the switch and without adding overload on the resources like CPU and Memory.	
		<ul style="list-style-type: none"> <li>• Flow path trace (ingress to egress switch)</li> <li>• Per Flow Hop by Hop packet drop with reason of drop</li> <li>• Per Flow latency (per switch and end to end)</li> </ul>	
		Should support software telemetry -	
		>Utilization of MAC table, Route table	
		Hardware resources like interface utilization, BW utilization	
		>Switch environment like CPU, memory, FAN and Power Supply unit	
	> Interface statistics like CRC errors etc.		
Switch should support monitoring using different type of Industry standard NMS tools using SNMP v3.			
Switch should provide different privilege for login into the system for monitoring and management			
All relevant licenses for all the features and scale should be quoted along with switch and all these licenses and features should be available from Day 1			
Software Defined Network Fabric Manager	Fabric Definition	Proposed fabric must be the Clos network topology architecture defined using Spine, Leaf switches with VXLAN overlay	
		Fabric should have following functionalities to be achieved:	
		Flexibility: Should allow workload mobility anywhere in the DC, across the Data Centre sites	
		Resiliency: The proposed fabric should be able to sustain multiple link and device (Leaf & Spine), Controller failures	



		Performance: The proposed fabric should be able to use full cross-sectional bandwidth (any-to-any) across all provisioned uplink ports using equal cost multi-pathing.	
		Solution should provide latency and drop analysis between end points connected to fabric with reason of drop.	
		fabric architecture:	
		Mult-Data Center design: The proposed architecture should provide a single pane for provisioning, monitoring, and management to deploy stretched policies across multiple Data centres. It should have federated (Manager of managers) management plane to push consistent policies across all the sites	
		All relevant licenses for all the features and scale should be quoted along with switch and all these licenses and features should be available from Day 1.	
	Hardware and Interface Requirement	Leaf switches to Spine connectivity should be through uplink port using line rate 100G only	
		In the fabric, the leaf and spine switches quoted should be non-oversubscribed and perform at line rate	
		All switches including Spine and leafs should be of line rate including access ports and uplink ports. All the interfaces should be non-blocking.	
		All switches & proposed Fabric must support minimum 1000 VRFs/Private networks without any additional component upgrade or design change	
		Fabric should support scale up and scale out without any service disruption.	
		Fabric must support minimum of 02 leaf switches	
		Fabric must support minimum of 02 spine switches and scale up to 06 spine switches without any design change.	
		Fabric must support a minimum 1000 tenants without any additional component upgrade or design change.	
	Fabric General Features	Fabric must support various Hypervisor encapsulation including VXLAN 802.1ad and VLAN 802.1q natively without any additional hardware/software or design change.	
		The fabric architecture must be based on hardware VXLAN overlays to provide logical topologies that are abstracted from the physical infrastructure with no performance degradation. Fabric must support VXLAN Switching/Bridging and VXLAN Routing.	
		Fabric must support Role Based Access Control in order to support Multi - Tenant environment.	

		<p>Fabric must integrate with different Hypervisor Managers viz. Vmware vCenter, Microsoft Hyper-V with System Center, Kubernetes, Redhat Openshift and manage virtualise networking from the single pane of Glass - Fabric Controller/SDN Controller for visibility of VM/Container at the controller level</p>	
		<p>Fabric must integrate with all proposed L4 - L7 Physical and virtual appliances using single pane of glass i.e. Fabric Controller or SDN Controller</p>	
		<p>Solution should provide L2 &amp; L3 extension across multiple sites/ Data Centres</p>	
		<p>Fabric must act as single distributed layer 2 switch, Layer 3 router and Stateless distributed firewall.</p>	
	<p>Fabric Security Features</p>	<p>Fabric must have zero trust policy model for directly connected systems or hosts in order to protect against any kind of attacks like Unauthorized Access, Man - in - the - middle – attack, Replay Attack, Denial of Service and to protect against Data exfiltration. The solution should support enforcement of application whitelist policies on external security devices including SDN, Load balances and Firewalls.</p> <p>Fabric must provide RBAC policies and support AAA using Local User authentication, External RADIUS, External TACACS+, External LDAP and</p> <p>The solution must integrate with orchestration tools to ingest workload tags and annotations &amp; enrich application context of the workloads dynamically. The solution should provide capability to create customer Forensic rules to identify process behavior deviations and provide alerts and notifications.</p> <p>Fabric /SDN controller should support micro-segmentation rules and policies for workloads connected to DC fabric for east-west traffic. It must also support micro-segmentation based on VM attributes like hostname, OS, VM Tags, FQDN, Microsoft AD based classification. The solution must also provide micro segmentation capability on application end host at remote location sites in offline mode (once policy is applied from the DC to workloads on remote sites, in case the sites are dis-connected, the enforcement policy is retained). Mentioned feature/capability should be achieved using same OEM products for a seamless integration, without using any external/3rd party solution.</p> <p>The solution must capture and analyze flow and process telemetry from all workloads</p>	

		<p>across all DCs, in real time and store in a time-series for long data retention of minimum 3 months. It should automatically generate per application whitelist policy and enforce the auto generated whitelist policy allowing only the required traffic, blocking everything else.</p> <p>Fabric must support Micro Segmentation for the Virtualized and Non - Virtualized environment (Bare metal and Container).</p> <p>Fabric must act as a State-less distributed firewall with the logging capability.</p> <p>The solution should provide capability to identify process behavior anomalies and deviations including MITRE attack pattern and provide alerts and notifications.</p> <p>Multi DC fabric solution should provide encryption between sites using 256-bits AES. The solution must also provide full audit logging of all system access and changes applied.</p> <p>Fabric must be capable of inserting physical and virtual L4 - L7 (FW, LB, IPS) services dynamically between multiple segments using policy-based traffic redirect.</p> <p>The solution must detect, remediate, and notify of any brute force override of the segmentation policy implementation.</p>	
	Cloud Ready (Hybrid/Multi Cloud)	<ul style="list-style-type: none"> <li>Fabric architecture must support seamless network and security extension to multiple cloud as well. Centralized controller is able to provide seamless connectivity within cloud, across clouds and onpremise to cloud.</li> <li>Centralized controller must provide complete visibility into Cloud Environment.</li> </ul>	
	Fabric management	<p>Fabric must provide Centralised Management Appliance or SDN Controller - Single pane of glass for managing, monitoring and provisioning the entire Fabric within Data Centre &amp; across all Data</p>	
		Centres	
		Fabric must Auto discover all the Spine and Leaf switches and auto	
		provision them based on the Fabric policy using Centralized Management appliance or SDN Controller.	
		Centralized management appliance or SDN Controller should not participate in Data plane and control plane traffic path of the fabric.	
		The proposed solution should provide an option to drill down directly from any problematic transaction to:	
		i) the server instance which was executing that	

		<p>transaction and provide visibility into health of the server and other transactions getting executed in that node</p> <ul style="list-style-type: none"> <li>ii) related DB instance in-context with the queries that are being executed</li> <li>iii) in-context OS level metrics</li> <li>iv) correlated application logs from available log files</li> </ul>	
		<p>The solution must capture and analyze flow and process telemetry from all workloads across all DCs, in real time and store in a time-series for long data retention of minimum 3 months.</p>	
		<p>The solution must provide capability to edit and modify the discovered policies to define and include more absolute InfoSec protection policies. It must export the policy to Network fabric, security devices etc.</p>	
		<p>The solution must provide application dependency map. As part of the application dependency map it must provide detailed and accurate application to application and service relations and inter-dependencies.</p>	
		<p>The solution must integrate with external systems such as vCenter, Kubernetes, IPAM or CMDB to bring in additional context for each application workload.</p>	
		<p>The proposed solution should have a robust analytics engine that can ingest application performance, custom and business data from multiple sources such as:</p> <ul style="list-style-type: none"> <li>i) Application transactions</li> <li>ii) End user browser requests and sessions</li> <li>iii) End user mobile requests and sessions</li> <li>iv) Application logs</li> </ul> <p>This analytics module should have a provision to query the ingested data through UI and also a full fledged query language to perform advanced analytics to provide insights into application performance impact on a process flow through business journey mapping, impact analysis of an issue over a period of time on users, regions and functionalities, release analytics, conversion of business KPIs to trackable metric, experience level management etc.</p>	
		<p>The proposed solution must provide comprehensive coverage for container based microservices monitoring along with container orchestration layer monitoring support. The solution should be able to monitor the container images and the services running on those images. There should be no requirement to change the container images to enable monitoring in case of applications based on technologies like Java. The solution should</p>	

		also be capable of pulling information from the orchestration layers like kubernetes/openshift and present relevant metrics like pod metrics, node metrics, deployment metrics, endpoint metrics etc.	
		Centralised management appliance or SDN Controller must communicate to south bound devices using open standard protocols i.e.	
		OPFLEX, OPENFLOW, OVSDB etc. or using Device APIs.	
		Centralised management appliance or SDN Controller must run in "N +1" redundancy to provide availability as well as to function during a split-brain scenario.	
		In the event of failure of all Centralised management appliances or SDN Controllers, the fabric must function with the current configuration and	
		without any performance degradation.	
		Centralized management appliance or SDN Controller must provide real-time device inventory and network topology of the fabric. It must	
		also validate the cabling connectivity and generate alarms in case of wrong or faulty connectivity.	
		All the infrastructure including hardware and licenses required by fabric	
		controllers to support the listed features and scale, should be provided by the Implementation Agency.	
		All the features mentioned in this document shall be available from Day 1. Hardware, Solution Software and licenses should be supplied from Day 1 to support these features.	
		Solution should be able to store historical data to provide anomalies and trending information of each resource (environment, configuration & operational) and graphical representation of parameters to help debug.	
		Solution should provide an automated mechanism to find configuration deviations, security risks & non-compliances against segmentation rules by assessing current configuration, network security policies and generate alert for any deviation to provide assurance.	
		Solution should provide network visibility and historical analysis between any two timeframes to identify any issues and changes including user information	
		The solution should provide pre-change analysis of the configuration to highlight any challenges and issues before pushing the	

		configuration within the fabric to reduce the risk of network failures and human errors for a robust change management.	
		Solution should provide instant visibility into any relevant and applicable bugs, security advisories and field notices for running hardware and configuration	
		Solution should support bug, PSIRT etc visibility	
Leaf Switch	Solution Requirement	The Switch should support non-blocking Layer 2 switching and Layer 3 routing	
		Switch should support the complete STACK of IPv4 and IPv6 services.	
		The Switch should have the capability to function in line rate for all ports	
	Hardware and Interface Requirement	Switch should have the following interfaces:	
		Minimum 48 ports support 1/10/25 Gbps SFP ports for host connectivity and 6*100G ports for Fabric/Spine connectivity. The proposed switch should support native 25G and should be populated with 48*10G Multimode fiber transceivers for downlink connectivity & 6*100G ports with multimode 100G Trancievers, for uplink connectivity . All the transceivers should be from the same OEM as the switch.	
		All SFPs should be considered as per BOQ from Day 1	
		Switch should have console port for local management & Out of band management interface for remote management	
		Switch should be 1 RU fixed form factor	
		Switch should be rack mountable and support side rails, if required.	
		Switch should be provided with redundant power supply units	
	Performance Requirement	Switch should support dedicated process for each routing protocol	
		Switch should re-converge all dynamic routing protocols at the time of routing update changes i.e. Graceful restart for fast re-convergence of routing protocols like OSPF, IS-IS, BGP.	
		Switch should support minimum 1000 VRF instances with route leaking functionality	
		The switch should support min 800k IPv4 LPM routes	
The switch should have MAC Address table size of 500k			
The switch should support 100K multicast routes			
Switch should support 4000 VLANs			
Switch should support minimum 64 ECMP			

		paths	
		Switch should support minimum 3.6 Tbps of switching throughput	
		Device should be based on simple and intelligent shared-memory egress buffered architecture that simplifies the system buffer management and queuing implementation.	
		The Switch should support intelligent buffer management with a minimum buffer of 36 MB.	
Network Features	Virtualization	Switch should support VXLAN to achieve Network Virtualisation.	
		Switch should support VXLAN and EVPN symmetric IRB for supporting Spine	
		Switch must provide the capability to be integrated with different Hypervisor Managers viz. Vmware vCenter, Microsoft Hyper-V with System Center, Kubernetes, Redhat Openshift and manage virtualise networking from the single pane of glass	
Layer2 Features		Spanning Tree Protocol (IEEE 802.1D, 802.1W, 802.1S)	
		Switch should support VLAN Trunking (802.1q)	
		Switch should support minimum 90k of MAC addresses	
		Switch should support VLAN tagging (IEEE 802.1q)	
		Switch should support IEEE Link Aggregation and Ethernet Bonding functionality (IEEE 802.3ad) to group multiple ports for redundancy	
		Switch should support Link Layer Discovery Protocol as per IEEE 802.1AB for finding media level failures	
		Switch should support layer 2 extension over VXLAN across all Data Centers	
		to enable VM mobility & availability	
		The Switch should support DC Bridging i.e. IEEE 802.1Qbb Priority Flow Control (PFC), Data Center Bridging Exchange (DCBX), IEEE 802.1Qaz Enhanced Transmission Selection (ETS), Explicit Congestion Notification (ECN).	
		The switch should support Minimum 48 number of port channels	
		A port channel should support up to 32 no. of ports	
		The switch should support BGP EVPN Route Type 2, Type 4 and Route Type 5 for the overlay control plane	
	Layer3 Features		Switch should support static and dynamic routing
		Switch should support segment routing and VRF route leaking functionality from day 1	
		Switch should support VRF, VRF Edge, Virtual	

		Router to achieve multi instance routing	
		Switch should provide multicast traffic reachable using PIM-SM, PIM-SSM and Multicast Source Discovery Protocol (MSDP), IGMP v1, v2 and v3	
	Quality of Service	Switch should support 802.1P classification and marking of packet using CoS (Class of Service) and DSCP (Differentiated Services Code Point)	
		Switch should support different type of QoS features for real time traffic differential treatment using Weighted Random Early Detection and Strict Priority Queuing	
		Switch should support Rate Limiting - Policing and/or Shaping	
		Switch should support to trust the QoS marking/priority settings of the end points as per the defined policy	
	<b>Security</b>	Switch should support control plane Protection from unnecessary or DoS traffic by control plane protection policy. Switch must provide the capability of micro-segmentation rules and policies for the Virtualized and Non - Virtualized environment (Bare metal and Container) workloads connected to DC fabric for east-west traffic. It must also support micro-segmentation based on VM attributes like hostname, OS, VM Tags, FQDN, Microsoft AD based classification. The solution must also provide micro segmentation capability on application end host at remote location sites in offline mode (once policy is applied from the DC to workloads on remote sites, in case the sites are dis-connected, the enforcement policy is retained). Mentioned feature/capability should be achieved using same OEM products for a seamless integration, without using any external/3rd party solution.	
		Switch should support external database for AAA using TACACS+ and RADIUS. Switch must provide the capability of inserting physical and virtual L4 - L7 (FW, LB, IPS) services dynamically between multiple segment using policy-based traffic redirect.	
		Switch should support to restrict end hosts in the network in order to	
		secure the port by limiting the number of learned MAC addresses to avoid MAC address flooding. Switch must support the capability to be used in the network fabric to act as a State-less distributed firewall with the logging capability	



		Switch platform should support encryption of traffic i.e. MAC Sec Encryption (802.1AE) in hardware	
		VXLAN and other tunnel encapsulation/decapsulation should be performed in single pass in Hardware	
		Switch should support Role Based access control (RBAC) for restricting host level network access as per policy defined	
		Switch should support DHCP Snooping	
		Switch should support Dynamic ARP Inspection	
		Switch should support IP Source Guard	
		Switch should support unicast and multicast blocking on a switch port to suppress the flooding of frames destined for an unknown unicast or	
		multicast MAC address out of that port.	
		Switch support broadcast, multicast and unknown unicast storm control to	
		prevent degradation of switch performance from storm due to network attacks and vulnerabilities. Both the SAN switch and the Spine/Leaf switches should be from the same OEM	
		The Switch should support LLDP.	
		Switch should support Spanning tree BPDU protection	
	Manageability	Switch should support for sending logs to multiple centralized syslog server for monitoring and audit trail	
		Switch should provide remote login for administration using SSHv2	
		Switch should support for capturing packets for identifying application performance using local and remote port mirroring for packet captures	
		Switch must have Switched Port Analyzer (SPAN) with minimum 4 active session and ERSPAN on physical, Port channel, VLAN interfaces	
		Switch should support monitoring status using different type of Industry standard NMS using SNMP v3.	
		Switch should provide different privileges for login in to the system for monitoring and management	
		Should have Open APIs to manage the switch through remote-procedure calls (JavaScript Object Notation [JSON] or XML) over HTTPS after secure	
		authentication for management and automation purpose.	
		The Switch Should support monitor events and	

		take corrective action like a script when the monitored events occur.	
		Should support hardware telemetry without impacting performance of the switch and without adding overload on the resources like CPU and Memory. • Flow path trace (ingress to egress switch) • Per Flow Hop by Hop packet drop with reason of drop • Per Flow latency (per switch and end to end)	
		Should support software telemetry >Utilization of MAC table, Route table Hardware resources like interface utilization, BW utilization >Switch environment like CPU, memory, FAN and Power Supply unit > Interface statistics like CRC errors etc.	
	Availability	Switch should have provision for connecting to 1:1/N+1 power supply for usage and redundancy	
		Switch should provide gateway level of redundancy IPV4 and IPV6 using HSRP/VRRP	
		Switch should support for BFD For Fast Failure Detection	
	Miscellaneous Points	Console cable and power cable (As per Indian standards) as per customer requirement to be provided. All Cables shall be factory-terminated.	
		All Functionalities of Switch shall be IPv6 compliant, and it should work on IPv6 Platform without any additional hardware/ software.	
		Switches and Transceivers should be from same OEM.	
		All relevant licenses for all the features and scale should be quoted along with switch	
SAN Switch	General Requirement	The proposed director or chassis-based solution must have complete redundancy in case of failure including hot swappable control plane module/supervisor, fabric modules, fan modules, power supplies, software modules on the OS	
		The switch (or director platform) must be able to provide minimum 196 - 16/32-Gbps FC and should have integrated/external FCIP module with minimum 8 FC port of 8/16-Gbps and 8 ports of 1/10 Gbps with all supported licenses from day one. Switch should support Fiber Channel, FCIP and FICON.	
		The switch should be able to support (or in future) 32G FC speeds on all 196 ports at line rate. Providing an aggregate bandwidth of 24Tbps.	
		The switch must have non-blocking architecture and be capable of dropping bad /	

		corrupt frames at the ingress of the switch by checking the ingress/egress packet against CRC.	
		The switch must support the following modules types in the same chassis: <ul style="list-style-type: none"> <li>• 4/8/16/32-Gbps FC Module</li> <li>• 8/16/32-Gbps FC Module</li> <li>• minimum 8 nos of 1/10 Gigabit Ethernet FCIP ports</li> </ul>	
		All FC ports for device connectivity should be 16/32 Gbps auto-sensing Fiber Channel ports.	
		The switch must be able to support non-disruptive software upgrade.	
		The switch must be able to support stateful process restart.	
		The switch must support port aggregation of up to 16 physical ports. The aggregated ports must NOT be consecutive ports on a line card and should support distributed model. The port channel should support trunk/port channel members from different ASICs / modules ports into a single aggregated link to ensure that the bundle can remain active in the event of a port, Application-Specific Integrated Circuit (ASIC), or module failure.	
		The switch should be completely programmable. Should support REST framework and be able to handle various industry standard formats. It should have the ability to reply to outside/3rd party management station requests in JSON/XML format.	
		It should natively support power-on auto provisioning (POAP) to automate software image upgrades and configuration file installation on newly deployed switches.	
		Switch/director should support FC and FCIP cards in the same chassis. The FCIP card should deliver min of 40G of FCIP with a single line card.	
		The switch should support Virtual SAN and inter VSAN routing for sharing resources across VSAN. Switch should be able to deliver line-rate routing between any ports in a system or fabric without the need for external routing appliances.	
		Switch should provide end-to-end visibility, from the virtual machine to the storage resource with resource allocation and performance measurements.	
		Switch should provide comprehensive tool set for analyzing, troubleshooting, and debugging storage networks. Features like POST diagnostics, Online diagnostics, SPAN and RSPAN, Fibre Channel traceroute, Fibre	

		Channel ping, Fibre Channel debug, Fabric Analyzer, Syslog, Online system health, Port-level statistics, Real-Time Protocol (RTP) debug etc should be supported	
		SAN Switch should provide end to end visibility of fibre channel SAN traffic. It should inspect I/O flow to bring out a unified view of the infrastructure irrespective of the architecture or vendor of storage arrays, servers or operating systems.	
		Switch should have capability to monitors ITL/ITN flows between the compute and storage layers, including the read and the write transactions between a host and the backend storage. All these metrics should be used to generate health reports. These reports should reveal the health of the overall storage infrastructure and applications.	
		Analytics solution must support minimum 100,000 ITL/ITN flows for deep SAN Visibility. Export metrics should be at 30-sec granularity. We should be able to export 1000 flows. We should get per flow performance metrics, latency metrics, error metrics for every ITL/ITN	
		The analytics and telemetry capabilities should not impact production traffic and should be built into the hardware platform. The complete analytics calculations should be done real time.	
		The telemetry data extracted from the inspection of the frame headers should be calculated on board (within the switch hardware) and, using an industry-leading open format, can be streamed to any analytics-visualization platform.	
		There should be common Operating System family for Data Center Ethernet switching and SAN Switching for simplified Software Management across Data Center.	
		There should be common OEM Provided Fabric Management and monitoring software for Managing Data Center Ethernet switching and SAN Switching for ease of operations.	
		Chassis must support Virtual Output Queue (VOQ) to ensure line-rate performance on each port, independent of traffic pattern, by eliminating head-of-line blocking.	
		The switches should have 80 Plus Platinum certified power supplies and should provide GRID level redundancy.	
		Switch shall be able to support FCIP with any generation of OEM switches without any compatibilitiy issues.	
		SFPs proposed alongwith switches should be compatible with any generation of SAN	

		switches for investment protection.	
		Switch must support anticounterfeit security with secure boot to avoid any tampering and additional security	
Management Switch	General Specifications	Switch should be rack mountable in standard 19" rack.	
		Switch should support internal field replaceable unit redundant power supply from day 1.	
		Switch should have minimum 2 GB RAM and 2 GB Flash.	
		Switch should have dedicated slot for modular stacking, in addition to asked uplink ports. Should support for minimum 48 Gbps of stacking throughput with 8 switch in single stack.	
	Performance	Switch shall have minimum 128 Gbps of switching fabric and 95.23 Mpps of forwarding rate.*	
		Switch shall have minimum 16K MAC Addresses and 250 active VLAN.	
		Should support minimum 11K IPv4 routes or more	
		Switch shall have 1K or more multicast routes.	
		Switch should support atleast 16K flow entries	
		Switch should support 128 or more STP Instances.	
		Switch should have 6MB or more packet buffer.	
	Functionality:	Switch should support IEEE Standards of Ethernet: IEEE 802.1D, 802.1s, 802.1w, 802.1x, 802.3ad, 802.3x, 802.1p, 802.1Q, 802.3, 802.3u, 802.3ab, 802.3z.	
		Switch must have functionality like static routing, RIP, PIM, OSPF, VRRP, PBR and QoS features from Day1	
		Switch should support network segmentation that overcomes the limitation of VLANs using VXLAN and VRFs.	
		Switch shall have 802.1p class of service, marking, classification, policing and shaping and eight egress queues.	
		Switch should support management features like SSHv2, SNMPv2c, SNMPv3, NTP, RADIUS and TACACS+ .	
		Switch should support IPv6 Binding	

		Integrity Guard, IPv6 Snooping, IPv6 RA Guard, IPv6 DHCP Guard, IPv6 Neighbor Discovery Inspection and IPv6 Source Guard.	
		Switch should support 802.1x authentication and accounting, IPv4 and IPv6 ACLs and Dynamic VLAN assignment and MACSec-128 on hardware for all ports.	
		Switch must have the capabilities to enable automatic configuration of switch ports as devices connect to the switch for the device type.	
		During system boots, the system's software signatures should be checked for integrity. System should be capable to understand that system OS are authentic and unmodified, it should have cryptographically signed images to provide assurance that the firmware & BIOS are authentic.	
	Interfaces	Switch shall have 24 nos. 10/100/1000 Base-T ports and additional 4 nos. of SFP+ uplinks ports.	
	Certification:	Switch shall conform to UL 60950 or IEC 60950 or CSA 60950 or EN 60950 Standards for Safety requirements of Information Technology Equipment.	
		Switch shall conform to EN 55022 Class A/B or CISPR22 Class A/B or CE Class A/B or FCC Class A/B Standards for EMC (Electro Magnetic Compatibility) requirements.	
		Switch / Switch's Operating System should be tested for EAL 2/NDPP or above under Common Criteria Certification.	
	DMZ Switch	Same as Leaf Switch	

### 6.3.3.3 Backup Solution

Backup Solution must be built up separately in the DC and the DRC. The solution must use the Disk to Tape schema.

Device	Specification	Details	Compliance
Tape Library	Capacity	Offered tape Library shall support Native Data Capacity of 3PB (uncompressed) expandable to 4PB using LTO-9 technology	
		Shall be offered with minimum of 3 (Three) numbers of LTO-9 tape drive. Drives shall support encryption in each location.	
		Shall be offered with at least 40 Cartridge slots and Scalable up to 280 slots	

		Shall be offered with a minimum number of cartridges that will be necessary and sufficient for taking a copy of the entire current backup in cartridge, in addition to 30 new cartridges and 2 Cleaning Cartridges.	
	Tape Drive Architecture	Offered LTO-9 drive in the library shall conform to the Data Rate Matching Technique for higher reliability.	
		Tape Drive Architecture in the Library shall conform to the INCITS T10 standard ADI Protocol or newer Benchmarks.	
	Scalability	Tape Library shall be scalable to a minimum of 20 number of drives and 250 Cartridge slots when fully populated.	
	Speed	Offered LTO-9 Drive shall support 300MBPS in Native Mode	
	Connectivity	Offered Tape Library shall provide native 8GPPS FC connectivity to SAN switches	
	Partitioning	Offered Tape Library shall have flexibility to configure each offered drive into a separate partition. Offered tape Library shall support minimum of 20 drives when fully populated.	
	Encryption Device	Offered Library shall be provided with a hardware device like USB key, a separate device etc. to keep all the encrypted keys in a redundant fashion.	
	Management	Tape Library shall provide web based remote management	
	Barcode Reader and Mail Slots	Tape Library shall support Barcode Reader and mail Slot	
		Tape Library shall be offered with 5 mail slots and shall be scalable to 20 slots when fully populated.	
	Other Features	Tape Library shall have GUI Panel	
		Shall be Rack mountable	
		Shall have option for redundant Power Supply	
		Tape Library shall be supplied With software which can predict and prevent failures through early warning and shall also suggest the required service action.	
		Offered Drives in the Tape Library shall optionally support both data path and control path failover.	
Backup Appliance with Backup Software	Appliance	Offered Disk to disk backup device shall be of modular design to allow configuration and addition of capacity increase performance.	
		Offered appliance shall be certified to work with at least 3 leading Backup Application vendor ISV like Zerto, Veeam, Commvault, Spectrum Protect, etc.	
	Capacity and Scalability	Offered device shall be capable of using the existing Disk system at WBSDEDCL.	
		The Offered device shall have a minimum of 400TB of usable backup space including WBSDEDCL existing disk space	
		Offered device shall also be scalable to at least 800TB of usable space in Native Mode (without deduplication and compression).	
	General Features	The backup Solution must use the D2D2T technology for backup within the Data Center. Blocks backed up for 30 days are to be backed up in disks and backups more than 30 days must automatically move to Tape Library.	
		Backed up blocks in the Tape Library must be retrievable to disk based backup as a part of the backup solution.	
		Backup solution should be image level backup solution specifically designed for VMware and Hyper-V Virtual Environments. Proc License.	
		Backup solution should be totally agent less but should support application aware backup processing. Solution should be Agentless and should not require license, deploy, manage or monitor on hosts or VMs	
		Backup solution should be Hardware Agnostic Solution and it should support any type of storage for storing the Backups.	
Backup solution should store a backup recovery point as a single file.			

		Backup solution should provide the RTO equal to High Availability and be able to boot the Virtual Machines directly from the Backup to reduce the downtime	
		Backup solution should provide Recovery of Application Items, File, Folder and Complete VM recovery capabilities from the image level backup within 15Mins RTO.	
		Solution shall have native feature for Automated Backup Verification. Automated restore should happen to an isolated sandbox environment to allow for non-disruptive testing of backups according to user-defined schedules. This ensures that backups are 100 % recoverable.	
		Recovery verification should automatically boot the server from backup and verify the recoverability of VM image, Guest OS, and Application Consistency	
		Solution should provide Backup and Replication capabilities in one console.	
		The Solution should support varieties of backup mechanisms like Full, Incremental, Differential etc. at different frequencies i.e., yearly, monthly, weekly, daily, hourly etc. as per defined policy. It should also have calendar-based backup scheduling. The restoration should also be supported accordingly.	
		Replication should include failover and failback capabilities and automated re IP and Networks mapping with Replica Seeding. In Normal stage, VMs are replicating from primary location to DR site. But in the time of DR Drill, corresponding application should replicate from DR to primary site.	
		The proposed solution should run on minimal licenses and cost effective thus reducing total cost of the solution. License should consider the case :- In Normal stage, VMs are replicating from primary location to DR site. But in the time of DR Drill, corresponding application should replicate from DR to primary site.	
		Solution should support 24x7 real-time monitoring, with at-a glance and drill-down views of health, performance, and workload of the virtual hosts.	
		The proposed Backup solution must Support Seamless Integration with Point-in-time SAN snapshots with Major OEM SAN Storages to perform faster LAN Free Backup without any overhead to Hypervisor Compute Layer.	
		The Solution should be Network-efficient, Secure backup data replication with variable-length encryption at the source, along with compression and encryption to ensure that backups are optimized for WAN transmission. This should be ensured without need of any other 3rd party WAN Accelerator requirements.	
		Vendor shall not use any additional staging device between Disk based backup and tape Library. ....	
		Offered Solution must be able to integrate with the existing solution such that the existing backups are copied into the new backup solution	
		Offered device shall have deduplication licenses, low bandwidth replication license so that, only unique non duplicated blocks only get transferred to DRC or other remote locations.	
		Offered device shall have intelligence to understand both sources based and target-based deduplication and shall be integrated with all well-known backup ISVs mentioned above.	
		Offered device shall support receiving non duplicated data from remote locations directly from the Application Server / Client Servers in low bandwidth mode without using any backup or replication-based device	



		at remote location.	
		Offered disk-based backup device shall also support secure erase feature for protecting against unauthorized recovery of deleted data.	
		Offered Disk based backup appliance shall support VLAN tagging. Offered IP ports of same type shall also support Port bonding in Adaptive Load balancing as well as Active Backup Mode.	
Data Protection		Offered Device shall be protected with Hardware RAID6 from the factory so that, no RAID configuration is required in field for data drives.	
Protocol		Offered device shall support emulation of both VTL and NAS target like NFS and CIFS	
		Offered device shall have capability to do complete copy of data sets from On Premise disk backup storage to tape storage instead of data Tiering.	
VTL Features		Offered device shall have the ability to configure at least 128 Tape Libraries and NAS targets along with 1,000,000 or more cartridge slots in a single appliance.	
		Offered device shall have capability to deliver selective restore from Disk Library itself.	
Front end Ports		Offered device shall have a minimum of 4 X 25GBps SFP IP ports and 4 X 40GBps QSFP28 ports. Licenses and SFP ports must be configured	
		Offered Appliance fiber channel ports shall support connectivity of servers either directly or via SAN switches while supporting both source and target-based deduplication.	
Encryption		Offered disk-based backup device shall also support encryption functionality.	
Throughput		Offered device shall support rated write performance of at least 25TB per hour	
Backup Software License		The backup Solution should be proposed with licenses necessary and sufficient for all the current VMs plus 25% more from Day 1 and additional licenses must be available for purchase within the service period of 8 years, for a cost not more than 5% year on year of the original cost of purchase.	
Brand & Model		Bidders are required to disclose if the proposed model release date	
Array Architecture		a) The proposed array should be an enterprise-class, employing NVMe-based all-flash storage with a tightly integrated scale-up and scale-out architecture. It should allow for independent scaling of compute controllers and media enclosures.	
		b) The proposed array should feature an end-to-end NVMe multi-controller architecture, delivering comprehensive NVMe performance.	
		c) The Proposed storage should be a pure block storage system mandatorily supporting FC & iSCSI Protocols	
Controller		a) The proposed array must include a minimum of 2 controllers, with scalable upgrades to 4 or more for future expansion.	
		b) The array should offer high resiliency with either an active-active or active-active controller pair configuration.	
		c) Automatic failover between active controllers must occur in the event of controller failure, ensuring uninterrupted performance at full workload capacity.	
Cache/Memory Management		a) The proposed array should feature a minimum of 1.5 TB Global/Controller DRAM Cache, expandable to 6 TB or more, where SSD/Flash drives are not considered part of the cache.	
		b) The storage solution should include mechanisms to safeguard cache data during power outages by securely transferring it to non-volatile disk storage.	
Capacity Management		a) The array should be configured with at least 300 TiB of usable capacity. Out of 300TiB, 165 TiB should be from NVMe SSD/NVMe Flash drives and rest using NLSAS with no more than 8TB drives, after implementing industry-standard RAID-6 or equivalent, without utilizing data reduction technologies such as compression or deduplication.	

		b) One global hot spare or similar technology for spare should be supplied for every 24 data disks.	
NVMe Flash Drives		a) The proposed array must support the latest dual-ported industry-standard NVMe SSDs / Flash drives with sizes of 7.68 TB, 15.36 TB, or higher.	
		b) A minimum of 96 NVMe SSD/NVMe Flash Drive should be supported by the proposed array for scalability purposes.	
		c) The proposed array should be configured with drive sizes of not more than 20TB for 8(a).	
Performance		a) Offered storage should be configured to deliver at least 100K IOPS with workload characteristics of 64KB block size, with 90% write.	
		b) The vendor must furnish proof/certificate/benchmarking documents from the OEM to demonstrate that the proposed array meets the required IOPS.	
Front-End and Backend connectivity		a) The proposed array should be equipped with at least 16x32Gbps FC adapter and 8x10Gb Ethernet ports for Host connectivity and separate port for the management.	
		b) The storage should have sufficient dedicated back-end ports for connecting disk enclosures & controllers, ensuring no data/disk loss in case of controller failure.	
No Single point of Failure		a) The proposed array must eliminate single points of failure (SPOF), ensuring all components are redundant and hot-swappable, including power supply, fan, and battery modules.	
		b) Replacement of failed hardware components, firmware upgrades, and hardware upgrades should not disrupt operations.	
Operating System & Clustering Support		a) The array should support multiple operating systems such as Windows, Unix, Linux, Solaris, AIX, HP-UX etc.	
		b) The storage should be compatible with clustering solutions such as Microsoft Cluster, MS SQL Cluster, Sun Solaris Cluster, Linux Cluster, etc.	
		c) Integration with major databases like Oracle, MS-SQL, MySQL, MongoDB, DB2, etc., should be available.	
Virtualized Environment Support		The proposed array must support virtualized server environments like VMware vSphere, Microsoft Hyper-V, and should seamlessly integrate with vSphere Virtual Volumes (VVOL), VAAI, and VASA.	
Quality of service		a) The required software/tool should offer unlimited storage capacity and enable rapid troubleshooting in case of performance issues.	
		b) The storage should provide Quality of Service (QoS) to allocate bandwidth to desired servers or ports, with the ability to restrict IOs or throughput to LUNs or Volumes.	
		c) The proposed array must support partitioning of resources at logical and/or physical levels, covering front-end ports and logical volumes.	
High Availability Solution		a) The proposed arrays should facilitate active-active replication at a metro distance, enabling logical volumes to be presented in RW mode simultaneously across two sites for disaster recovery and workload balancing.	
		b) The solution should support RPO=0 and RTO=0 solution for supported OS & applications.	
		c) The metro-cluster should not be suspended or failover due to failure of the arbitration mechanism between local and metro-distant sites, with native capability of the storage array.	
Remote Three-Site Replication		a) The remote replication solution should support three-way replication in both Concurrent and Cascaded configurations, ensuring no data loss. Concurrent replication should employ synchronous and asynchronous modes, while Cascaded replication should synchronize data from the Primary site to the Near site in synchronous mode and from the Near site to the DR site in asynchronous mode.	
		b) The proposed arrays should support 10GbE or 25GbE connectivity for remote replication over IP.	
		c) The remote replication solution should allow switching between synchronous and asynchronous modes for the same volumes.	
		d) The replication solution should safeguard remaining sites in case of a single-site failure and support incremental updates between the remaining two sites.	
		e) Replication licenses must be provided for delivered capacity from Day 1.	
Storage Array		a) The proposed storage array must support management via CLI, GUI, and	

Configuration & Management Software	RESTful API, including compatibility with the CSI driver for Kubernetes and automation capabilities with Ansible and vRO.	
	b) The storage solution should provide a unified GUI interface for centralized management of all arrays across the three sites, while offering the flexibility of a local GUI interface for individual array management at each site.	
	c) The storage management software should seamlessly integrate with Active Directory/LDAP for user authentication.	
	d) The proposed array should be equipped with an On-Premise performance monitoring and reporting tool, delivering comprehensive utilization reports for storage, including metrics such as space utilization, throughput, IOPS, read/write response time, and read/write ratio. It should support historical performance reporting, trending, and storage utilization reports.	
	e) The storage management software should include advanced features like generating end-to-end topology visualization and offer multi-pathing software solution with failover and load balancing functionality.	
	f) The storage system should provide a multi-pathing software solution equipped with failover and load balancing functionalities, deployable across an unlimited number of hosts.	
	g) The system should facilitate immediate recovery of files, databases, and complete volumes from snapshot copies.	
	h) The proposed storage should ensure a minimum of 256 point-in-time application consistent snapshots per volume/LUN, ensuring snapshots do not occupy additional space upon creation, with the license for the entire usable capacity included.	
	i) The proposed storage system should support software tailored for fast, space-efficient, application-consistent, disk-based backups and clone management, enhancing recovery point objectives (RPOs) and recovery time objectives (RTOs) for protected applications.	
	j) The proposed system should include licenses/software simplifying backup, restore, and clone management by permitting mountable snapshots and clones without disrupting production operations.	
	k) The storage system should offer capabilities for creating backup copies across multiple sites and enabling data replication across backup targets, providing any necessary licenses.	
	l) The proposed array should support instantaneous restoration of the source volume from point-in-time copies, making it immediately available to the host for production processing while the restore process operates in the background.	
	m) The proposed array should support manual creation of snapshots or snapshots through snapshot policies for a single source volume, enabling granular recovery. Additionally, it should offer scheduling options for snapshot creation, deletion, and expiration.	
	Data Reduction Technology /Storage Efficiency	a) The proposed array should support both in-line and post-process efficiency features such as Compression, De-Duplication, and Compaction.
	b) The proposed array should support inline compression and deduplication of application data for improved space efficiency. It should offer the flexibility to enable or disable the data reduction feature on an application storage group (single LUN or multiple LUNs) as needed.	
Security and Encryption	a) The proposed storage array should support AES-XTS 256 data-at-rest encryption, adhering to FIPS 140-2 certification requirements. This encryption should be manageable either by an On-board Key Manager or an External Key Manager using a cryptographic security module.	
	b) The proposed array must offer an audit service to record activities, including host-initiated actions, physical component changes, and blocked attempts by security control. The audit log should remain secure and tamper-proof.	
	c) The storage system should provide capabilities for visibility, detection, and remediation of ransomware attacks.	
	d) The proposed array must have the ability to create multiple secure and immutable snapshots of the source volume to safeguard against intentional or accidental deletion. Users should not possess the capability to delete, expire, or modify the contents of these secure snapshots.	

	Support Backup Software vendor	The proposed Storage Systems should support and integrate with Backup Software Solutions like Commvault & Veeam. All features, including parameters mentioned in this document, supported by the proposed storage array, should be included in a bundled license provided from the first day of deployment for the required usable capacity.	
	Licenses	a) The proposed arrays should be accompanied by their own Storage Rack/Cabinet with PDU and Power Cables.	
	Implementation &	a) The implementation of the proposed storage system should be executed by the OEM Professional Service Team, ensuring a comprehensive approach encompassing planning, design, configuration, implementation, and meticulous documentation.	
	Data Migration	b) The proposed Storage System should be capable of non-disruptive data migration from existing IBM V5K, IBM V7K, IBM DS8K storage systems for 340TiB usable capacity.	
	Service	c) Data Migration Service should also be conducted by the OEM Professional Service Team as part of the implementation process.	
	BoQ	e) A comprehensive Bill of Quantities (BoQ) of proposed storage systems with hardware, software, and licenses should be submitted.	
	New Features	The bidder should clearly delineate new features/services/devices unique to the offered technology solution other than the mentioned required items. These will undergo technical evaluation and may receive preference.	
Management Servers for Backup		To be provisioned from the Virtualised Cloud Platform. Adequate OS, CPU, Memory, Boot Disk Space, Hypervisor License and support are to be provisioned in the Virtual Server Platform for hosting the backup Management Solution.	

#### 6.3.3.4 RISC Server and Applications.

WBSEDCL wants to retain current 2 No. of IBM Power 8 Servers, deployed in Year 2019. These servers have to be used to host any Prod & Non-Prod Workloads like App, TEST, DEV, Quality, STAGING, PREPROD, HADR etc. These servers can be used to host Prod APP Workloads. These servers cannot be used to host any Prod DB/Failover Workloads as and when required by WBSEDCL.

#### Configuration of 2 No. of existing Servers in DC –

Server 1: 9080-MHE with 91 Cores & 2560 GB RAM with AIX & PHA licenses respectively.

Server 2: 9080-MHE with 127 Cores & 3712 GB RAM with AIX & PHA licenses respectively.

#### Configuration of 1 No. of existing Server at DRC-

9080-MHE with 77 Cores & 2432 GB RAM with AIX licenses respectively.

#### Proposed specification of RISC/EPIC Server(s). RISC/EPIC Server Specification Rack based.

Technical Parameter	Technical Specification Required	Complied (Yes /No)
Proposed Server(s)	<p><b>Data Center, Rajarhat:- 2 nos</b> - Server 1 of DC site Shall be configured with min 6 lakhs SAPS (considering 100% CPU utilization) with 25% vertical scalability in terms of SAPs where each virtual/physical servers should have vertical scalability of 25% of its proposed saps.</p> <p>- Server 2 of DC site Shall be configured with min 6 lakhs SAPS (considering 100% CPU utilization) with 25% vertical scalability in terms of SAPs where each virtual/physical servers should have vertical scalability of 25% of its proposed saps.</p> <p>- Servers proposed should have Free DIMMs slots from Day-1 to scale up to 32 TB.</p>	

	<p><b><u>Disaster Recovery Center, Berhampore:- 1 no.</u></b> - Server of DRC site Shall be configured with min 9 lakhs SAPS (considering 100% CPU utilization) with 10% vertical scalability in terms of SAPs where each virtual/physical servers should have vertical scalability of 10% of its proposed saps.</p> <p>- Servers proposed should have Free DIMMs slots from Day-1 to scale up to 32 TB.</p> <p>Servers shall be allocated with all resources based on SAPs sizing table. Higher ratings are acceptable.</p> <p>Proposed hardware should be aligned with the application product roadmap in next 7 years. Implementation Agency needs to provide necessary supportive documents regarding the same.</p> <p>In view of limited space, power (limited up to total 30KW for two 42U racks including equipment at DC) &amp; cooling infrastructure available in the Data Centre, new hardware infrastructure proposed by the Implementation Agency should not exceed these constituents.</p> <p>All servers shall be capable of being partitioned, each partition should have its own operating system instance, host name and IP address.</p> <p>Detailed power consumption at peak load &amp; cooling requirement (in BTU/hr) to be mentioned for each physical server.</p> <p>Redundant, hot swappable, power/cooling units. Each power supply to have its independent power cord.</p> <p>Servers should be HANA compatible &amp; certified to run multiple Production HANA DB instances</p> <p>Latest Datasheets for all the Physical servers &amp; software associated with it should be offered.</p>	
Processor (CPU)	<p>All the UNIX servers at each site shall be of the same make and model and have the same type of RISC/EPIC based 64-bit processors/cores. (Note: - Processor should be of latest generation from OEM)</p> <p>CPU must be of the latest generation available with the OEM at the time of bidding for that particular model being quoted</p> <p>OEMs shall not quote any Pre – release CPU or model w.r.t. the date of bidding.</p> <p>CPU of the mentioned servers shall provide proposed saps under 100% utilization.</p>	
No. of Processor	<p>Proposed server(s) should be configured with minimum 8 core per processor which will be able to cater vertical upgradation requirement of each logical/physical servers along with minimum 25% additional scalability options in terms of saps count for DC &amp; 10% additional scalability options in terms of saps count for DR. Implementation Agency needs to provide necessary documents to support the same.</p>	
SAPS Benchmarking	<p>The Implementation Agency needs to submit SAP published SD 2 tier / SD 3 tier benchmark certificate or OEM's SAP competency center certificate for server model being offered, meeting the required processing capacity. SAPS/CORE should be minimum 3000 SAPs/Core.</p>	
Processor Speed	<p>The offered processor should be the latest offering and must have at least 3 GHz or better clock speed.</p>	
Cache memory	<p>Minimum Cache memory should be available to meet the requirement as per scope of work.</p>	
Memory (RAM)	<p>Proposed RAM should meet with the requirement. DDR4 RAM to be provided 5 TB each for DC &amp; 6 TB for DR with scalability to increase RAM upto 32 TB with current compute proposed. Servers proposed should have Free DIMMs slots from Day-1 to scale upto 32 TB.</p> <p>Independent SWAP space on internal disk or external disk for each partition/server should be configured with minimum equivalent or 2 times the size of RAM allocated</p>	

	for that partition/server.	
Reliability Availability & Serviceability Features	The system should be able to detect and bypass a failed component and automatically recover upon reboot	
	Error correction and parity checking for improved data integrity	
	Selective dynamic firmware updates	
	Advanced Remote Management features	
	Processors should be capable of dynamic CPU allocation / de-allocation.	
	Certified for standard safety measures.	
	Each of the offered physical server(s) inside the rack should have redundant (at least two) service processors.	
	The offered servers should support continuous error checking of the system which is to be monitored by the Service processors.	
	Chipkill protection for x4 DDIMMs, with DRAM sparing	
	Pre failure Alert capabilities should be available.	
	All the mentioned components should be hot pluggable components – Disks, Power Supplies, Fans etc.	
	PCI buses should have error handling mechanism.	
	Indicators to identify failed components.	
	Media bays	Min one Media Bays per System
Maximum Internal Disk Support	To meet WBSIEDCL's present and future requirement as mentioned above.	
	Disks shall be mirrored. HDDs can be local or in the SAN.	
Bus technology	PCIe Gen4, also compatible to PCIe Gen5	
I/O Slots	Sufficient numbers of PCIe Gen3/4 slots are required. Implementation Agencies to provide dedicated ports with redundancy for production environment as per requirement.	
	Ethernet Adapters should be provided for each server/partition in automatic Fail-over / Redundant / trunking / Link aggregation and auto switching mode. Relevant S/W, licenses shall be provided. Server proposed should have at least 40 Ports of 10G SR Optics+ for Network Connectivity	
	All required Fibre Channel Host Bus Adapters (minimum 32 Gbps) with multi-path I/O trunking and automatic load balancing should be provided for each server/partition. The vendor must offer this capability either through the OS or software provided by the storage solution (minimal impact on performance). All the compatible required hardware and software for this need to be provided. Server proposed should have at least 40 Ports of 32G Fiber for SAN Connectivity	
	Database VMs & their Failovers should be configured with Dedicated IO adapters or Shared IO adapters with dedicated IO Ports.	
	All partitions/servers should have local, shared or remote media access to a DVD & LTO drive	
	USB/Serial Ports shall be supplied as per the standard availability in the model offered.	
	DVD Drive	DVD-RAM Drive
Power supply	Redundant Hot Swappable power supply and Cooling fan/subsystems	
Partitions(in case of virtualization scenario)	Each instance should run in an independent partition having its own operating system, host name & IP address.	
	Enterprise Edition of Virtualization software should be provided by OEM.	
	Each UNIX partition shall be able to run same or different versions of OS Kernel, patch levels independently.	
	Any configuration change in one UNIX partition should not affect any other UNIX partition unless desired.	
	The O/S, of each UNIX partition shall be upgradeable independently without affecting the other UNIX partitions.	

	An error/fault in one UNIX partition should not bring the entire system or other UNIX partitions down.	
	All UNIX partitions on physical servers shall support display of performance characteristics through SAP CCMS.	
	Each UNIX partition shall have the capability to start-up and shut-down independently without affecting any other UNIX partition on the same server.	
	It should be possible to assign processors and memory logically to any partition or switch processors and memory between partitions without reboot of source or target partitions.	
	Each Partition shall have its own dedicated adapters/controllers for production environment only.	
	Partition is allowed for unix server up to CPU core/sub-core level depending on the technology availability of the OEM.	
	There shall be adequate security features to protect one partition from other partition on the same server.	
Clustering	The partitions/servers specified in cluster shall be in high availability cluster. Dedicated partition on separate physical server for fail-over is mandatory.	
	Redundant Heart beat paths to be provided; paths to be physically isolated from each other.	
	Dedicated cluster/heartbeats ports (using dedicated single or dual port cards) shall be provided.	
	Cluster solution shall be OEM/SAP certified solution.	
	The cluster solution must be able to provide fail-over to the other system for any failure arising in one of the system due to: SAP process in any of the two systems Database Operating System Partition Failure Server hardware failure Any other failure which causes the server/partition to fail.	
	The High Availability cluster shall be with adequate redundancy and with equal performance and configuration and will have access to the same database and storage.	
	Each partition/server shall have the minimum resources allocated as per the sizing specified. At any point of time resources of partitions should not run with lesser resources for production servers as mentioned above..	
	The solution shall provide for all the necessary hardware and software components. Requisite no. of licenses required for high availability and clustering needs to be provided.	
	Once the failed system comes up, it should revert back to the original configuration automatically. Option for reverting back manually should also be available.	
	No committed transactions in SAP should be lost in case of failure of clustered server/partition.	
	The proposed solution of implementing the fail-over must be explained in detail in the technical proposal along with logical diagrams. The documentation should identify the failure scenarios (for ex. Failure of a partition, failure of a server with multiple partitions, failure of SAN switches, failure of storage) with detailed expected behaviour, interruptions if any to the end user etc. for both fail-over and fail back. The purchaser reserves the right to include one or more of these scenarios as part of the commissioning.	
	Necessary software and scripts for automatic cluster fail-over to be supplied. It should be seamless fail-over without manual intervention.	
	There should not be any single point of failure in the offered solution. Each cluster should have multiple interconnect through different Ethernet & fibre switches.	
Operating System	There should not be any single point of failure in the offered solution. Each cluster should have multiple interconnect through different Ethernet & fibre switches.	
	OS should be capable for integration and migration of the system.	

	Any migration from existing Operating System/Platform to target Operating System/Platform proposed should be owned by OEM.	
	Operating System Features should be as follows:- Logical Volume Management. Workload Management Software should be offered. Journalled File System. Mirroring Software should be offered. Shall be capable of running 64-bit SAP.	
	The Unix Operating Systems shall be licensed to support unlimited users.	
	Partition management software having dynamic configuration feature with GUI/ Web interface. Management Consoles for the same to be provided.	
	All the OS should be delivered on latest patch level.	
	Software and licenses to be provided for resource allocation/de-allocation to SAP instances	
Management Software	Shall provide health status, alerts and monitors of system resources.	
	Shall Notifies, downloads and installs updates for systems.	
	Shall be able to perform actions based on system events.	
	Shall be able to Create, edit, relocate and delete virtual resources.	
	Shall provide a remote console, a command line and file transfer features to target systems.	
Virtualization (If required)	Proposed UNIX server(s) should be virtualized to meet the requirement as specified in the SAP sizing table.	
Form factor/Node Type	42 U or as per OEM, Rack Mountable with required rail kit (to be provided)	
Warranty	3 years on site with full labour, parts & replacement from OEM with (24 X 7) support. Minimum end of Support (EoS) and End of Life (EoL) from OEM after Supply -7 Years (supporting document from OEM should be provided).	

***Instead of Internal Disk, San Boot is also allowed and for that case vendor has to provide all the required necessary accessories like Storage, Controller, network equipment, fiber connectivity etc. in redundant configuration.***

#### 6.3.3.4 Disk Storage

Over and above the specifications of the storage to be a part of the Hyper Converged Interface, here are the specifications of the Disk storage that are to be used as Primary Storage i.e., Data and Secondary Storage, for Backup.

Parameter		Compliance
Brand & Model	Bidders are required to disclose the proposed model release date	
Array Architecture	a) The proposed array should be enterprise-class, employing NVMe-based all-flash storage with a tightly integrated scale-up and scale-out architecture. It should allow for independent scaling of compute controllers and media enclosures. b) The proposed array should feature an end-to-end NVMe multi-controller architecture, delivering comprehensive NVMe performance. c) The Proposed storage should be a pure block storage system mandatorily supporting FC & iSCSI Protocols	
Controller	a) The proposed array must include a minimum of 2 controllers in redundancy, with scalable upgrades to 4 or more for future expansion. b) The array should offer high resiliency with either an active-active or active-active controller pair configuration. c) Automatic failover between active controllers must occur in the event of controller failure, ensuring uninterrupted performance at full workload	



	capacity.	
Cache/Memory Management	a) The proposed array should feature a minimum of 2 TB Global/Controller DRAM Cache, expandable to 6 TB or more, where SSD/Flash drives are not considered part of the cache.	
	b) The storage solution should include mechanisms to safeguard cache data during power outages by securely transferring it to non-volatile disk storage.	
Capacity Management	a) The array should be configured with at least 500 TB of usable capacity in DC and 400 TB usable capacity in DRC using the latest NVMe SSDs/NVMe Flash Drives, after implementing industry-standard RAID-6 or equivalent, without utilizing data reduction technologies such as compression or deduplication. Additional space for snapshot/point-in-time copy/clone/journal capacity for Async Replication must be provided by the storage provider, amounting to at least 10% of the total usable capacity for the proposed array.	
	b) One global hot spare or similar technology for spare should be supplied for every 24 data disks.	
NVMe Flash Drives	a) The proposed array must support the latest dual-ported industry-standard NVMe SSDs / Flash drives with sizes of 7.68 TB, 15.36 TB, or higher.	
	b) A minimum of 96 NVMe SSD/NVMe Flash Drive should be supported by the proposed array for scalability purposes.	
	c) The proposed array should be configured with drive sizes of not more than 20TB for 8(a).	
Performance	a) Offered storage should be configured to deliver at least 500K IOPS with workload characteristics of 8KB block size, 70:30 Read-to-Write (R:W) ratio, and response time (RT) of less than 1ms.	
	b) The vendor must furnish proof/certificate/benchmarking documents from the OEM to demonstrate that the proposed array meets the required IOPS.	
Front-End and Backend connectivity	a) The proposed array should be equipped with at least 32x32Gbps FC adapters for Host connectivity and separate port for the management.	
	b) The storage should have sufficient dedicated back-end ports for connecting disk enclosures & controllers, ensuring no data/disk loss in case of controller failure.	
No Single point of Failure	a) The proposed array must eliminate single points of failure (SPOF), ensuring all components are redundant and hot-swappable, including power supply, fan, and battery modules.	
	b) Replacement of failed hardware components, firmware upgrades, and hardware upgrades should not disrupt operations.	
Operating System & Clustering Support	a) The array should support multiple operating systems such as Windows, Unix, Linux, Solaris, AIX, HP-UX etc.	
	b) The storage should be compatible with clustering solutions such as Microsoft Cluster, MS SQL Cluster, Sun Solaris Cluster, Linux Cluster, etc.	
	c) Integration with major databases like Oracle, MS-SQL, MySQL, MongoDB, DB2, etc., should be available.	
Virtualized Environment Support	The proposed array must support virtualized server environments like VMware vSphere, Microsoft Hyper-V, and should seamlessly integrate with vSphere Virtual Volumes (VVOL), VAAI, and VASA.	
Quality of service	a) The required software/tool should offer unlimited storage capacity and enable rapid troubleshooting in case of performance issues.	

	b) The storage should provide Quality of Service (QoS) to allocate bandwidth to desired servers or ports, with the ability to restrict IOs or throughput to LUNs or Volumes.	
	c) The proposed array must support partitioning of resources at logical and/or physical levels, covering front-end ports and logical volumes.	
High Availability Solution	a) The proposed arrays should facilitate active-active replication at a metro distance, enabling logical volumes to be presented in RW mode simultaneously across two sites for disaster recovery and workload balancing.	
	b) The solution should support RPO=0 and RTO=0 solution for supported OS & applications.	
	c) The metro-cluster should not be suspended or failover due to failure of the arbitration mechanism between local and metro-distant sites, with native capability of the storage array.	
Remote Three-Site Replication	a) The remote replication solution should support three-way replication in both Concurrent and Cascaded configurations, ensuring no data loss. Concurrent replication should employ synchronous and asynchronous modes, while Cascaded replication should synchronize data from the Primary site to the Near site in synchronous mode and from the Near site to the DR site in asynchronous mode.	
	b) The proposed arrays should support 10GbE or 25GbE connectivity for remote replication over IP.	
	c) The remote replication solution should allow switching between synchronous and asynchronous modes for the same volumes.	
	d) The replication solution should safeguard remaining sites in case of a single-site failure and support incremental updates between the remaining two sites.	
	e) Replication licenses must be provided for delivered capacity from Day 1.	
Storage Array Configuration & Management Software	a) The proposed storage array must support management via CLI, GUI, and RESTful API, including compatibility with the CSI driver for Kubernetes and automation capabilities with Ansible and vRO.	
	b) The storage solution should provide a unified GUI interface for centralized management of all arrays across the three sites, while offering the flexibility of a local GUI interface for individual array management at each site.	
	c) The storage management software should seamlessly integrate with Active Directory/LDAP for user authentication.	
	d) The proposed array should be equipped with an On-Premise performance monitoring and reporting tool, delivering comprehensive utilization reports for storage, including metrics such as space utilization, throughput, IOPS, read/write response time, and read/write ratio. It should support historical performance reporting, trending, and storage utilization reports.	
	e) The storage management software should include advanced features like generating end-to-end topology visualization and offer multi-pathing software solution with failover and load balancing functionality.	
	f) The storage system should provide a multi-pathing software solution equipped with failover and load balancing functionalities, deployable across an unlimited number of hosts.	
	g) The system should facilitate immediate recovery of files, databases, and complete volumes from snapshot copies.	
	h) The proposed storage should ensure a minimum of 256 point-in-time application consistent snapshots per volume/LUN, ensuring snapshots	

	do not occupy additional space upon creation, with the license for the entire usable capacity included.	
	i) The proposed storage system should support software tailored for fast, space-efficient, application-consistent, disk-based backups and clone management, enhancing recovery point objectives (RPOs) and recovery time objectives (RTOs) for protected applications.	
	j) The proposed system should include licenses/software simplifying backup, restore, and clone management by permitting mountable snapshots and clones without disrupting production operations.	
	k) The storage system should offer capabilities for creating backup copies across multiple sites and enabling data replication across backup targets, providing any necessary licenses.	
	l) The proposed array should support instantaneous restoration of the source volume from point-in-time copies, making it immediately available to the host for production processing while the restore process operates in the background.	
	m) The proposed array should support manual creation of snapshots or snapshots through snapshot policies for a single source volume, enabling granular recovery. Additionally, it should offer scheduling options for snapshot creation, deletion, and expiration.	
Data Reduction Technology /Storage Efficiency	a) The proposed array should support both in-line and post-process efficiency features such as Compression, De-Duplication, and Compaction.	
	b) The proposed array should support inline compression and deduplication of application data for improved space efficiency. It should offer the flexibility to enable or disable the data reduction feature on an application storage group (single LUN or multiple LUNs) as needed.	
Security and Encryption	a) The proposed storage array should support AES-XTS 256 data-at-rest encryption, adhering to FIPS 140-2 certification requirements. This encryption should be manageable either by an On-board Key Manager or an External Key Manager using a cryptographic security module.	
	b) The proposed array must offer an audit service to record activities, including host-initiated actions, physical component changes, and blocked attempts by security control. The audit log should remain secure and tamper-proof.	
	c) The storage system should provide capabilities for visibility, detection, and remediation of ransomware attacks.	
	d) The proposed array must have the ability to create multiple secure and immutable snapshots of the source volume to safeguard against intentional or accidental deletion. Users should not possess the capability to delete, expire, or modify the contents of these secure snapshots.	
Support Backup Software vendor	The proposed Storage Systems should support and integrate with Backup Software Solutions like Commvault & Veeam. All features, including parameters mentioned in this document, supported by the proposed storage array, should be included in a bundled license provided from the first day of deployment for the required usable capacity.	
Licenses	a) The proposed arrays should be accompanied by their own Storage Rack/Cabinet with PDU and Power Cables.	

Implementation	a) The implementation of the proposed storage system should be executed by the OEM Professional Service Team, ensuring a comprehensive approach encompassing planning, design, configuration, implementation, and meticulous documentation.	
Data Migration	b) The proposed Storage System should be capable of non-disruptive data migration from existing IBM V5K, IBM V7K, IBM DS8K storage systems for 340TiB usable capacity.	
Service	c) Data Migration Service should also be conducted by the OEM Professional Service Team as part of the implementation process.	
BoQ	e) A comprehensive Bill of Quantities (BoQ) of proposed storage systems with hardware, software, and licenses should be submitted.	
New Features	The bidder should clearly delineate new features/services/devices unique to the offered technology solution other than the mentioned required items. These will undergo technical evaluation and may receive preference.	

In addition to the above Storage Array for Data, another storage is to be proposed by the IA for back

## 6.4 Installation and Commissioning

The Implementation Agency should prepare a detailed Implementation and Upgradation plan for installation of the device at the DC- DRC location.

- The Implementation Agency should access the existing IT landscape at the DC DRC location and prepare the plan for the upgrade and implementation. Access as required, will be approved by WBSEDCL personnel as per IT Security Guideline.
- The Implementation Agency should submit details report on the list of the network equipment that have not reached EoL and EoS. Also, should prepare plan to reuse the existing Network equipment as per the feasibility.
- The Implementation Agency should supply with the network appliance best fit for the defined IT landscape in the RFP and equipment should be scalable for future expansion.
- The implementation Agency must arrange in its own capability, to extend UPS power to the racks for all the new devices, in DC and DRC, from the Power Source provided by WBSEDCL. Cables and Industrial connectors and sockets to that effect must be arranged by the IA.
- The Implementation Agency should arrange all the required FO cables, patch Panels, FO Patch Cords required to build the SAN and Connect the Tape Systems and Servers for the newly created IT environment as well as any requirement for old IT set up at DC & DRC.
- Any Power augmentation required for the existing racks to accommodate the new devices are also to be arranged by the IA. All necessary supply and Services are to be supplied by the IA.
- The Implementation Agency should propose the method to take the existing equipment configuration backup and perform the successful implementation in the existing IT environment.
- The Implementation Agency should prepare proper documentation of the existing configuration, migration processes, access controls, custom configurations, and handover the document to the WBSEDCL stakeholders for future reference.
- The Implementation Agency should perform the POC with the proposed network equipment to showcase the required performance of the equipment.
- The Implementation Agency should implement the new features available with the devices as applicable for the existing environment.
- The Implementation Agency should ensure to perform the upgrade with minimum downtime.
- The Implementation Agency should complete the upgradation within the proposed timeframe.
- The Implementation Agency should have the roll back plan incase anything goes wrong.

- The Implementation Agency should have the contingency plan prepared for the entire migration process.
- The Implementation Agency should conduct thorough post-implementation testing to validate the new device performance.
- Implementation Agency should document all the processes involved in upgrade of the devices.
- The Implementation Agency should conduct training for the WBSEDCL stakeholders to make them aware of the functioning of the devices.
- The Implementation Agency should set up monitoring tools to track the performance of the devices.
- The Implementation Agency should evaluate existing security protocols and identify areas for improvement.
- The Implementation Agency should ensure OEM support availability during the upgradation activity for seamless migration of the network devices.
- The Implementation Agency should optimize Quality of service (QoS) for efficient performance of the devices.
- The Implementation Agency should involve end-users in testing critical applications to ensure seamless operation.

#### **6.4.1 Functional Requirements for a Software Defined Network with Spine Leaf Architecture Upgrade from 1G to 10G at DC and Conventional 1G Network setup at DRC.**

Upgrading a network from 1Gbps (Gigabit per second) to 10Gbps is a significant enhancement that necessitates careful planning and consideration of various functional requirements. This upgrade aims to increase bandwidth, reduce latency, and improve overall network performance to support current and future demands. Below are key functional requirements for a network upgrade from 1G to 10G. WBSEDCL will upgrade their DC to SDN and 10G or higher and will continue to keep their DRC in the Conventional network over 1G. The below functional requirements are to be complied with.

##### **6.4.1.1 For 1G to 10G**

##### **Hardware Compatibility and Upgrade**

- **Switches and Routers:** Ensure switches and routers support 10Gbps Ethernet/Fiber Optic This may involve upgrading existing hardware to models that can handle higher throughput and provide the necessary ports.
- **Network Interface Cards (NICs):** NICs in servers, storage devices, and workstations to 10Gbps-capable versions to fully utilize the increased bandwidth.
- **Cabling:** Any new or modification of cabling should be the responsibility of IA for successful implementation of the proposed IT/network solution without any additional cost to WBSEDCL. Verify or upgrade cabling to support 10Gbps speeds for new hardware and 1Gbps speeds for existing hardware, considering fiber optics for all new cabling and Cat6a or Cat7 cables for copper solutions if it is not supported with fiber optic cables.

##### **Linking with the existing 1G Network**

- The Upgraded 10G Spine Leaf Network must be linked to the existing 1G network seamlessly, in DC.
- Devices running in 1G network must be functioning in the current or higher speed.

##### **Network Infrastructure Enhancements**

- **Redundancy and Failover:** Implement or enhance redundancy and failover mechanisms to ensure network reliability and availability, especially critical given the increased reliance on network performance.
- **Power Over Ethernet (PoE):** If applicable, ensure that new switches support PoE+ or higher standards for devices requiring power, such as VoIP phones and wireless access points, without compromising the bandwidth.

### Performance and Capacity Planning

- **Bandwidth Management:** Tools and policies for bandwidth management to prioritize critical applications and ensure fair usage.
- **Traffic Analysis:** Upgrade monitoring tools to analyze traffic patterns and identify bottlenecks or unnecessary traffic that could be optimized or rerouted.

### Security Enhancements

- **Firewall and IDS/IPS:** Ensure firewalls and intrusion detection/prevention systems (IDS/IPS) are capable of handling 10Gbps traffic without becoming bottlenecks.
- **Secure Configuration:** Update security policies and configurations to handle increased traffic and potential new threats.

### Quality of Service (QoS)

- **Prioritization:** Implement or refine QoS policies to prioritize critical business applications and services, ensuring they receive the bandwidth and low latency they require.

### Scalability and Future-proofing

- **Modular Hardware:** Choose hardware that allows for expansion, such as modular switches with empty slots for additional 10Gbps or higher modules.
- **Virtualization Support:** Ensure network infrastructure supports virtualization technologies adequately for efficient resource utilization and network segmentation.

### Compatibility and Interoperability

- **Legacy Systems:** Consider how to integrate or phase out legacy systems that may not support 10Gbps, including potential use of media converters or dual-speed network devices.
- **Vendor Compatibility:** Ensure new hardware and software are compatible with existing equipment and software from various vendors to avoid interoperability issues.

### Training and Documentation

- **Staff Training:** Provide training for IT staff on managing and troubleshooting a 10Gbps network, including the use of any new tools or technologies introduced.
- **Documentation:** Update network documentation, including diagrams, configurations, and policies, to reflect the upgraded network infrastructure.

### Environmental Considerations

- **Cooling and Power:** Assess and upgrade data center or network closet cooling and power infrastructure to accommodate the potentially higher power consumption and heat output from 10Gbps equipment.

## Testing and Validation

- **Performance Testing:** Conduct thorough testing to validate the performance improvements, including latency measurements, throughput testing, and stress testing under peak load conditions.

### 6.4.1.2 Centralized Network Control for the Software Defined Network

- **Control Plane Decoupling:** Ability to separate the control plane (decision making) from the data plane (traffic handling), allowing for centralized management.
- **Network Programmability:** Support for programmable network controllers that can dynamically adjust network behavior based on application requirements.

## Abstraction

- **Infrastructure Abstraction:** Provide an abstracted view of the network to administrators and applications, hiding the complexity of underlying physical infrastructure.
- **Virtualization Support:** Enable network virtualization to support multiple virtual networks over a single physical infrastructure.

## Automation and Orchestration

- **Automated Configuration:** Support for automated network configuration and management, reducing manual intervention and the potential for human error.
- **Policy-based Management:** Enable the definition and enforcement of network policies that automatically configure and manage network behavior.

## Scalability

- **Dynamic Scaling:** The system should support scaling network resources up or down based on demand, without service interruption.
- **Future Proofing:** The network must be able to assimilate into a SDWAN that will be developed in future, without replacement of any hardware that are being replaced now. Any such replacement will have to be supplied by the Implementation agency of this project.
- **High Performance:** Maintain high performance levels even as the network scales, ensuring that control messages are processed efficiently and data plane performance is not compromised.

## Interoperability and Open Standards

- **Open APIs:** Support for open APIs (Application Programming Interfaces) such as OpenFlow, allowing for integration with a variety of network devices and software solutions.
- **Multi-Vendor Support:** Ensure compatibility with network devices and software from multiple vendors, preventing vendor lock-in and promoting a heterogeneous network environment.

## Security

- **Segmentation and Isolation:** Ability to create secure, isolated network segments for different users, devices, or applications, even within a shared infrastructure.
- **Encryption and Protection:** Implement encryption for data in transit and provide robust mechanisms for network monitoring and threat detection.

## Reliability and High Availability

- **Fault Tolerance:** Design the network to automatically reroute traffic in case of device or link failure, minimizing downtime.
- **Consistent Policy Enforcement:** Ensure that network policies are consistently applied and maintained across the entire network, regardless of underlying hardware changes or failures.

### Quality of Service (QoS) and Traffic Management

- **Traffic Shaping and Prioritization:** Support for advanced QoS features, enabling prioritization of critical network traffic and ensuring bandwidth allocation aligns with business priorities.
- **Congestion Management:** Implement mechanisms to detect and mitigate network congestion, ensuring optimal performance for all network applications.

### Monitoring and Analytics

- **Real-time Visibility:** Provide real-time visibility into network performance, traffic flows, and device status, enabling proactive management and troubleshooting.
- **Analytics and Reporting:** Offer detailed analytics and reporting tools to help administrators understand network usage patterns, optimize performance, and plan for future capacity needs.

### User and Device Management

- **Access Control:** Robust access control mechanisms to manage and authenticate user and device access to the network.
- **Device Flexibility:** Support for a wide range of devices, including IoT (Internet of Things) devices, ensuring they can be efficiently managed and secured.

### 6.4.1.3 Spine Leaf Architecture

#### Scalability

- **Easy Expansion:** Ability to easily add more spine or leaf switches as network demand increases without major reconfiguration, supporting both horizontal and vertical scaling strategies.
- **High Port Density:** Leaf switches should support high port density to accommodate a large number of connections from servers, storage, or other leaf switches.
- **Non-blocking Fabric:** The architecture should support a non-blocking or minimal blocking fabric to ensure that increases in traffic do not lead to congestion or performance degradation.

#### Performance

- **Low Latency:** The architecture must provide low-latency communication between any two points in the network, crucial for performance-sensitive applications.
- **High Throughput:** Support for high data throughput rates to meet the demands of data-intensive applications, such as big data analytics and high-performance computing.

#### Reliability and High Availability

- **Redundancy:** Implementation of redundant paths between any two points in the network to ensure continued operation in the event of a link or device failure.
- **Load Balancing:** Efficient load balancing across spine switches to optimize network utilization and prevent any single point of congestion.



- **Fast Failover:** Capability to quickly reroute traffic in case of failure to minimize downtime.

### Manageability

- **Simplified Management:** Centralized or simplified management tools that provide visibility and control over the entire spine-leaf fabric, making it easier to configure, monitor, and troubleshoot.
- **Automation:** Support for automation tools and APIs to streamline the deployment, configuration, and ongoing management of the network, reducing the potential for human error.

### Security

- **Segmentation and Isolation:** Support for network segmentation (e.g., VLANs, VXLAN) to isolate workloads and traffic for security and compliance purposes.
- **Access Control:** Robust access control policies and mechanisms to manage who can access the network and what resources they can use.
- **Threat Detection and Response:** Integration with security platforms for real-time threat detection and response to protect the network against malicious activities and vulnerabilities.

### Flexibility and Compatibility

- **Protocol Support:** Support for a range of networking protocols to ensure compatibility with existing network infrastructure and services, including IPv4/IPv6, MPLS, and BGP.
- **Multi-Vendor Environment:** Ability to operate in a multi-vendor environment, allowing for the integration of spine and leaf switches from different manufacturers.

### Quality of Service (QoS)

- **Traffic Prioritization:** Capabilities to prioritize traffic based on business needs, ensuring critical applications receive the bandwidth and resources they require.
- **Congestion Management:** Tools and protocols to manage and alleviate congestion within the network, ensuring stable and predictable network performance.

#### 6.4.1.4 Revamping of passive Cabling at the Data Center

Although passive cabling exists within the Data Center, yet any revamping of the same, as required, and necessary, is inherently included to ensure a complete infrastructure setup.

All incidental tasks related to revamping of passive cabling within the Data Center, including but not limited to cable management, patching, and infrastructure setup, shall be considered part of the Scope of Work (SOW).

Ensure that any revamping of passive cabling activities necessary for the functioning and organization of the Data Center environment are included in the project without any extra cost.

#### 6.4.1.5 Network readiness at Disaster Recovery Center:

The newly procured network equipment i.e. core routers, access control system should be installed and configured at DRC. The old running network equipment at DC may be taken at DRC for replacing the old unsupported critical network equipment. Any modification or configuration changes required during the installation of network at DRC, IA (Implementation Agency) will be the full responsible for the activity. Any new cabling or modification of cabling and proper tagging/marketing of cable for successful implementation of the Network is the responsibility of IA.

## 6.4.2 Functional Requirements of a Virtualized Server and Storage Setup

The newly built Server and storage system must be built in completely virtual setup enabling efficient resource utilization, simplified management, and enhanced flexibility. The x86 servers and storage listed in the table above are mostly EoS and are to be moved out of the DC and the DRC and new Virtual Servers and storage are to be used to replace them. All the current applications running in the x86 servers are to be implemented in the respective virtual servers as per the hardware specifications mentioned above and must have the functional requirements for server and storage virtualization platforms as the following key areas:

### Resource Abstraction and Pooling

- **Server Virtualization:** Ability to abstract physical server resources (CPU, RAM, and network interfaces) into multiple virtual machines (VMs), allowing for the running of multiple operating systems and applications on a single physical server.
- **Storage Virtualization:** Capability to pool storage resources from multiple network storage devices into a single storage device that is managed from a central console, enabling more efficient storage allocation and management.

### High Availability and Disaster Recovery

- **Automated Failover:** Systems should automatically transfer operations to standby servers or storage systems in the event of a failure to minimize downtime.
- **Data Protection:** Features for backup and recovery of virtual machines and data, including point-in-time snapshots, replication, and backup scheduling.

### Scalability

- **Dynamic Resource Allocation:** Ability to dynamically allocate or reallocate resources among virtual machines based on demand without disrupting operations.
- **Scale-Out and Scale-Up:** Support for both horizontal (adding more VMs or storage units) and vertical (adding more resources to existing VMs or storage pools) scaling.

### Performance Monitoring and Management

- **Monitoring Tools:** Comprehensive tools for monitoring the performance, capacity, and health of virtual machines and storage systems.
- **Resource Management:** Features for managing and optimizing the use of CPU, memory, storage, and network resources among virtualized workloads.

### Security and Compliance

- **Isolation:** Ensuring that virtual machines and storage volumes are completely isolated from one another to prevent unauthorized access or data leakage.
- **Access Control:** Robust access control mechanisms to manage user access to virtual resources, including role-based access controls.
- **Data Encryption:** Encryption of data at rest and in transit to protect sensitive information.

### Networking

- **Virtual Networks:** Capability to create and manage virtual networks, including virtual switches, routers, and firewalls, to support the communication needs of virtual machines.
- **Network Services:** Integration with network services like DHCP, DNS, and VPN to ensure virtual machines can efficiently connect to and communicate over the network.

#### **Compatibility and Interoperability**

- **Hypervisor Compatibility:** Support for popular hypervisors such as VMware ESXi, Microsoft Hyper-V, and KVM, ensuring broad compatibility with existing virtualization environments.
- **Storage Protocols Support:** Support for key storage protocols, including iSCSI, Fibre Channel, and NFS, ensuring compatibility with a wide range of network storage solutions.

#### **Management and Automation**

- **Centralized Management Console:** A unified management interface for configuring, managing, and monitoring virtual machines and storage systems.
- **Automation and Orchestration:** Tools and APIs for automating routine tasks, such as VM provisioning, storage allocation, and application deployment, and for orchestrating complex workflows across the virtual environment.

#### **Migration and Portability**

- **Live Migration:** Ability to move running virtual machines or storage volumes between physical servers or storage systems without downtime.
- **Portability:** Support for moving virtual machines and data between different virtualization platforms or cloud environments with minimal effort.

### **6.4.3 Functional Requirements of Backup Upgrade**

#### **Hardware Implementation:**

- Existing backed up data must be migrated to new solution, readable by the new system.
- A copy of the current system must be backed up before upgrading servers and storage.
- All current Back Policies must be implemented in the new backup solution.

#### **DISK to DISK to TAPE**

- Backup solution must use the D2D2T for backing up System and Data.
- The retention period of the disk backup will be ascertained by the OEM in discussion with WBSEDCL.
- A complete backup policy is to be finalized with WBSEDCL before implementing.

#### **Secure Backup & Fast Recovery**

- Fast, application-aware, image-based backups for Virtualised environment, NAS, Windows and Linux
- Native backup and recovery for On Premises Cloud
- Ransomware protection with immutable backups functionality.

## Recovery Orchestration

- **sub-minute RPO** and fail over to the latest state instantly.
- Immediate recovery and production data access for VMs, entire NAS shares and SQL/Oracle databases with immediate recovery.
- 1-click site recovery and DR testing with the solution.

## Proactive Monitoring & Analytics

- Unified monitoring and reporting across on premises, cloud and remote agents.
- Built in intelligence to identify and help resolve common misconfigurations and backup problems.
- Effective capacity planning and forecasting to keep your IT needs in check.

## Early Threat Detection

There must be built-in Malware Detection Engine performs low-impact, real-time data and file extensions analysis during backup for immediate malware detection.

## Protecting Reinfection

Pinpoint identified ransomware strains and prevent reintroduction of malware into your environment using YARA content analysis.

## Automate Clean Recovery

Perform orchestrated recovery of an entire environment using malware-free restore points.

## Recover With Precision

Roll back to the moment before the infection hits, ensuring minimal data loss

## Verify Security and Compliance

Boost recovery success with automated scans, which utilizing infrastructure hardening and data protection best practices.

## 6.4.4 Functional Requirements of RISC/EPIC Server Upgrade.

Installation and activity details along with resource allocation of virtual servers in the Existing 2 Nos RISC/EPIC servers at DC and 1 Nos. RISC/EPIC Servers at DRC is as follows: -

New Server - 1 in HA mode						
#	Partition Description	SAPS	Cores	RAM GB	OS	DB
	VIO x 2		2.0	48		
1	ERP DB	95342	12.2	763	Compatible OS	DB2
2	ERP BI CI	23836	3.1	191	Compatible OS	DB2
3	ECC SAP ISU DB	460606	59.1	3685	Compatible OS	DB2
	SUM	579784				
	<b>Summary Required</b>		<b>76.3</b>	<b>4686</b>		
	<b>Summary Configured</b>		<b>80.0</b>	<b>5120</b>		
12 x 12 Core RISC/EPIC Processor, (80 Cores or more Active), 5 TB RAM, 6 x 4P 32G FC, 8 x 2 port 10G SR Optics+, 4 x 6 Slot Expansion, 4 x 800G NVMe Disk						
New Server - 2 in HA mode						
#	Partition Description	SAPS	Cores	RAM GB	OS	DB
	VIO x 2		2.0	48		

1	ERP CI	95342	12.2	763	Compatible OS	DB2
2	ERP BI DB	23836	3.1	191	Compatible OS	DB2
3	ECC SAP ISU CI	460606	59.1	3685	Compatible OS	DB2
	SUM	579784				
	<b>Summary Required</b>		<b>76.3</b>	<b>4686</b>		
	<b>Summary Configured</b>		<b>80.0</b>	<b>5120</b>		
12 x 12 Core RISC/EPIC Processor, (80 Cores or more Active), 5 TB RAM, 6 x 4P 32G FC, 8 x 2 port 10G SR Optics+, 4 x 6 Slot Expansion, 4 x 800G NVMe Disk						

Server - 1 in DRC						
#	Lpar Name	SAPS	Cores	RAM GB	OS	DB
	VIO x 2		2.0	48		
1	DC_REP_DB_CI	95342	12	763	Compatible OS	DB2
2	PSBIWCI1_DB	23836	3	191	Compatible OS	DB2
3	NEW_ECC_DB_PR_DR	460606	59	3685	Compatible OS	DB2
4	SAP_ECC_APP1	33499	2	70	Compatible OS	DB2
5	SAP_ECC_APP3	33499	2	70	Compatible OS	DB2
6	SAP_ECC_APP5	33499	2	70	Compatible OS	DB2
7	SAP_ECC_APP8	33499	2	70	Compatible OS	DB2
8	NEW_SAPECC_APP12	33499	2	70	Compatible OS	DB2
9	NEW_SAPECC_APP11	33499	2	70	Compatible OS	DB2
10	ECCAPP10	33499	2	70	Compatible OS	DB2
	SUM	814274				
	<b>Summary Required</b>		<b>90.3</b>	<b>5176</b>		
	<b>Summary Configured</b>		<b>96.0</b>	<b>6120</b>		
12 x 12 Core RISC/EPIC Processor, (96 Cores Active), 6 TB RAM, 4 x 6 Slot Expn, 4 x 800G NVMe						

**The logical servers mentioned above, is the proposed configuration in the existing hardware. Implementation Agency shall be responsible for addition /orientation/installation/alteration/integration of logical servers to meet the above requirement.**

- Database, failover and other clustering including Rack to refresh existing setup & cater additional growth.
- DDR4 RAM to be provided, with scalability to increase RAM upto 32 TB with current compute proposed.
- Servers proposed should have Free DIMMs slots from Day-1 to scale upto 32 TB.
- Servers should be HANA compatible & certified to run multiple Production HANA DB instances.
- Clock speed for the proposed server (processor) should be at least 3 GHz
- SAPs delivery for proposed compute should be at least 11 Lakhs SAPS
- SAPS/CORE should be minimum 3000 SAPs/Core.
- This server should be fitted in one 42 U rack.

- Server proposed should with Latest Generation Processor available by OEM.
- Server proposed should have at least 40 Ports of 32G Fiber for SAN Connectivity
- Server proposed should have at least 40 Ports of 10G SR Optics+ for Network Connectivity
- Database VMs & their Failovers should be configured with Dedicated IO adapters or Shared IO adapters with dedicated IO Ports
- Necessary standard structured cabling and Power Cabling of DC & DRC locations must be arranged to make it suitable for installation of equipment.
- Undertake cabling necessary for system integration and overall solution as per international IT standards.
- The instances of SAP\_ERP, SAP\_ERP-BW which are in Power7 system and SAP\_ISU, which is in the Power8 system, is to be installed and migrated to the in the new RISC/EPIC setup in HA mode from the existing Power Systems.
- All other instances present in the Power5, Power6 and Power7 System is to be migrated to the Power8 system.
- Implementation Agency shall arrange for placement of SAP Technical consultant(s) with 5 Years of domain experience on site starting from Kick-off meeting till completion of post go-live onsite support to carry out all SAP related activity as per scope including migration and testing of SAP instances and resolution of any issues arising out of migration post Go-live at their own price.
- Implementation Agency will ensure configuration of DC-DR replication for all the application instances. One Synchronous HADR Standby database system to be maintained at DR.
- Implementation Agency must request for approval of downtime required for any of the activities mentioned in the scope of work. Implementation Agency has to manage all the activities as per approved downtime period and total downtime to be provided is as per discretion of WBSEDCL.
- Any kind of application performance issue arising out of the bottleneck in the infrastructure components must be owned and resolved by the Implementation Agency. To ensure smooth operation and diagnosis, Implementation Agency must provide system generated performance reports using proper tools on regular basis.
- Additional application servers, staging servers and any other kind of servers can be deployed to the proposed RISC/EPIC servers if any resources available after production deployment and Implementation Agency will be responsible for implementing the required deployment.
- SAP & Application support needs to be owned/validated by IA on new setup.
  - Any application/DB challenges w.r.t existing OS needs to be owned by IA on existing & new setup.
  - Upgrading/Updating SAP application/HANA Database is not in scope for this solution.
  - In case, WBSEDCL/existing FMS partner needs help, LABs Team needs to be involved in the solution. Labs scope must be included within the SCOPE.
  - IA needs to own the solution & ensure the compatibility w.r.t to Application/DB with existing OS and Proposed OS on existing & new setup.
  - Migration to be done by IA or OEM considering that existing servers/landscape/application will support proposed OS on old servers & all application related data that needs to be migrated is hosted on Storage only.

## 6.5 Migration of existing applications and services.

The Migration of existing applications will involve moving each running application and its associated data, OS and workload to the new environment. It provides a way to move apps to the virtualized environment without redesigning the app to suit the new infrastructure or fundamentally changing the workload.

- Implementation Agency will carry out the migration as per the agreed and approved documentation between WBSEDCL, existing FMS vendor of WBSEDCL and themselves.
- Any Operating System or Firmware Level upgradation required to fulfill the overall upgrade and migration of old system to new system must be taken care of by the IA, at no extra cost to WBSEDCL.
- In no case there may be a disruption of ongoing operation during migration. A RACI Matrix is attached herewith for the migration activity. However, this table is likely to be changed during the project.
- Any installation, reinstallation, configuration change, supply of materials to be done for the successful migration of the system must be supplied at no extra cost implication to WBSEDCL.

R: Responsible (Those who do the work to achieve the task).

A: Accountable (The one ultimately answerable for the correct and thorough completion of the task, and the one who delegates the work to those responsible. There should be only one A specified for each task to ensure clear ownership).

C: Consulted (Those whose opinions are sought; typically, subject matter experts).

I: Informed (Those who are kept up to date on progress, often only on completion of the task or deliverables).

Tasks/Activities	WBSEDCL & PMA	IT Operations Team	FMS	Implementation Agency (IA)
Project Planning	C	I		R, A
Define Migration Strategy, Plan	I	C		R, A
Assess and Document Application Inventory	C	C		R, A
Security and Compliance Assessment	I	C		R, A
Setup Migration Environment	C, I	R		R, A
Execute Migration	C	R		R, A
Testing and Quality Assurance	C, I	R		R
User Acceptance Testing (UAT) Coordination	I, R	C		R, A
Post-Migration Support	I	R		R, A
Training and Documentation for New System	C	I		R, A
Project Closure and Documentation	C, I	I		R, A

The first phase of migration must start with the migration of the network from 1G to 10G.

### 6.5.1 Migration of Network

**Benchmarking:** Before fully implementing the upgrade, benchmark the current network performance to have a baseline for comparison.

**Pilot Testing:** Conduct a pilot test of the 10G upgrade in a controlled environment or segment of the new network. at DC. Conduct a pilot test of the upgraded network after replacing and reconfiguring of newly procured/ running DC equipment in a controlled environment or segment of the new network at DRC.

**Performance Monitoring:** Network monitoring tools must be used to continuously monitor the performance after the upgrade.

**Phased Rollout:** It must be a phased approach to rolling out the upgrade.

**Documentation:** Update documentation to reflect changes made during the upgrade, including network diagrams, hardware inventories, and configuration settings.

The existing 1G Network that will be still under use is to be kept running during the migration.

All existing Servers and Storage are to run in new network environment at least their previous speeds during the network migration.

### 6.5.2 Migration of Applications to Virtual Server

**Assess the app and prepare for the move.** Consider how much pre-work needs to occur before the move, like updates and patches, and schedule that work.

**Identify any data or workload bottlenecks.** There must not be any bottlenecks leading to API access restrictions in the data transfer after the move.

**Verify compliance requirements.** Ensure all compliance requirements meet the migration plan and target infrastructure during and after the move.

**Create a migration priority list.** Ensure mission-critical apps migrate first.

**Reduce feature and scope creep.** Define a strategy to slowly integrate features the new environment may have and stick to it throughout the migration. Integrating new features all at once can lead to delays and interruptions.

**Both Systems must run** during the migration process. The old system will be shut down only post Go Live.

### 6.5.3 Migration of Storage Data to New Storage

**Assess Requirements:** The IA to understand the data volume, types, and specific application requirements. This includes performance, availability, and security needs.

**Inventory and Categorization:** The IA to Catalog all data and applications to determine what needs to be migrated and in what order. Prioritize data based on criticality and access frequency.

**Risk Assessment:** The IA to Identify potential risks and challenges associated with the migration, including downtime, data loss, and compatibility issues.



**Migration Strategy:** The IA to Develop a detailed migration strategy that includes phased migration, testing, and rollback procedures. Decide between online migration (no downtime) and offline migration (downtime required).

**Pilot Testing:** The IA to Conduct a pilot migration with a small, non-critical segment of the data. This helps identify potential issues and validate the migration process.

**Tool Selection:** The IA to Choose appropriate migration tools and software that match your specific requirements and infrastructure. Consider tools that offer automation, error checking, and reporting capabilities. The tools must be at no additional cost to WBSUEDCL.

**Schedule Migration:** The IA to Plan the migration during off-peak hours or scheduled maintenance windows to minimize impact on business operations.

**Data Backup:** The IA to Ensure that all data is backed up before starting the migration. This is critical for recovery in case of any issues.

**Implement Migration:** The IA to Execute the migration according to the planned phases, using the selected tools and following the migration strategy closely.

**Monitor and Manage:** The IA to Continuously monitor the migration process for errors or issues. Address any issues immediately.

**Data Integrity Checks:** The IA to Perform thorough data integrity checks to ensure that all data was migrated successfully and without corruption.

**Performance Testing:** The IA to Test the performance of the new storage solution to ensure it meets the expected parameters and supports the required workloads.

**Optimization:** The IA to Optimize storage settings and configurations for optimal performance and efficiency based on the observed performance and operational requirements.

**Update Documentation:** The IA to Document the new storage infrastructure, including architectural diagrams, configurations, and any changes made during the migration process.

#### **6.5.4 Backup Solution Migration and DC and DRC replication**

**Assess Current Setup:** The IA shall Understand the current IBM Spectrum Protect configuration, including data volumes, backup schedules, retention policies, and storage infrastructure.

**Inventory Data:** The IA shall Catalog all data backed up by IBM Spectrum Protect, including prioritization of data based on criticality and sensitivity.

**Compatibility Check:** The IA shall Ensure that the new backup solution is compatible with both the new and existing IT environment, including applications, databases, and storage systems.

**Feature Comparison:** The IA shall Compare the features and capabilities of IBM Spectrum Protect with the new solution, focusing on deduplication, encryption, cloud support, and disaster recovery options.

**Migration Tool Assessment:** The IA shall Investigate if there are any tools or services offered by the new backup vendor or third parties that facilitate data migration from IBM Spectrum

Protect. Such Onetime tool must not be charged to WBSEDCL and be used by IA for migration purpose only.

**Migration Strategy:** The IA shall Develop a detailed migration strategy, considering direct data migration paths or using interim storage as a staging area if a direct migration is not possible.

**POC:** The IA shall Conduct a pilot migration with a small set of data to validate the migration process, including data integrity, backup, and restore operations in the new system.

**Communication:** The IA shall Inform all stakeholders about the migration schedule and any expected impacts on backup and restore operations.

**Data Migration:** The IA shall Execute the migration according to the finalized plan. This may involve gradual migration of data, starting with non-critical systems to minimize risk.

**Policy and Configuration Migration:** The IA shall Migrate backup policies, schedules, and configuration settings from IBM Spectrum Protect to the new system, ensuring equivalent or improved data protection strategies.

**Data Integrity Checks:** The IA shall Perform comprehensive checks to ensure all data has been accurately migrated and is restorable from the new backup system.

**Performance Testing:** The IA shall Verify that the backup and restore performance meets or exceeds previous capabilities, adjusting configurations as needed.

**Update Documentation:** The IA shall Revise internal documentation to reflect the new backup environment, including operational procedures and disaster recovery plans.

**Monitor and Optimize:** The IA shall Continuously monitor the new system for performance, efficiency, and reliability. Optimize configurations based on operational feedback and evolving business needs.

**Safely Decommission IBM Spectrum Protect:** The Implementation Agency may, once confident in the new setup, decommission the IBM Spectrum Protect environment following data sanitization and software removal best practices to ensure no sensitive data is left behind.

#### **6.5.4.1 DC to DRC replication**

**Data Criticality:** IA must Identify critical data and applications that need to be replicated in real-time or near-real-time.

**RPO and RTO:** IA must Establish Recovery Point Objectives (RPO) and Recovery Time Objectives (RTO) to determine how frequently data needs to be replicated and how quickly it should be recoverable.

**Bandwidth and Latency:** IA must Consider the available network bandwidth and latency between the DC and DRC.

**Select Replication Technology:** IA must Under discussion with WBSEDCL and their existing replication strategy select between.

**Encryption:** IA must Ensure that data transmitted between DC and DRC is encrypted to protect it from unauthorized access.

**Access Controls:** IA must Implement proper access controls to restrict who can manage and access replicated data.

**Dedicated Network:** IA must use a dedicated network connection for replication to avoid congestion with regular data traffic.

**Firewall Configuration:** IA must Adjust firewall rules to allow replication traffic between DC and DRC.

**Pilot Replication:** IA must Conduct a pilot replication with a subset of data to ensure the process works as expected. This helps identify and address any issues before full implementation.

**Failover Testing:** IA must Test failover procedures to ensure that, in the event of a disaster, systems can be brought online at the DRC.

**Monitoring Tools:** IA must Implement monitoring tools to track the status of replication, detect issues, and provide alerts.

**Regular Audits:** IA must Conduct regular audits of the replication process to ensure it aligns with business requirements.

**Documentation:** IA must Maintain comprehensive documentation that includes replication procedures, failover steps, and troubleshooting guidelines.

**Data Compliance:** IA must Ensure that data replication processes comply with relevant data protection and privacy regulations.

**Disaster Recovery Plan:** IA must Develop a comprehensive disaster recovery plan that includes failover procedures and communication protocols.

**Regular Drills:** IA must Conduct regular disaster recovery drills to ensure that the DRC is capable of taking over operations in case of a disaster. The Go Live will be accepted only after one such drill.

### **6.5.5 RISC Server Migration to RISC/EPIC Servers.**

The RISC Server migration would be a double migration.

- The Existing Power 8 servers must be used to host any Non-Prod Workloads like TEST, DEV, STAGING, PREPROD, HADR etc. hence Migration from the existing Power 5, Power 6 and Power 7 server must be done. These servers can be used to host Prod APP Workloads. The Power 5, 6 and 7 servers are to be disposed of as Buy Back items.
- DB, CI, and ECC are to migrate to current Upgraded RISC/EPIC server from the existing Power 8 Servers.
- Installation configuration and reconfiguration of the HADR needs to be done post the migration of the RISC server system.

The entire migration is to be planned without any operational downtime.

Indicative Migration plan is provided below. Further changes required during the project is to be done as per WBS/DCL requirement.

**Migrated Landscape DC, Rajarhat.**

New Server - 1						
#	Lpar Name	SAPS	Cores	RAM GB	OS	DB
	VIO x 2		2.0	48		
1	DC_REP_DB	95342	12.2	763	Compatible OS	DB2
2	PSBIWCI1	23836	3.1	191	Compatible OS	DB2
3	NEW_ECC_DB_PR	460606	59.1	3685	Compatible OS	DB2
		579784				
	<i>Summary Required</i>		76.3	4686		
	<i>Summary Configured</i>		80.0	5120		
12 x 12 Core RISC/EPIC Processor, (80 Cores Active), 5 TB RAM, 4 x 6 Slot Expn, 4 x 800G NVMe Disk / SAN Boot						

New Server - 2						
#	Lpar Name	SAPS	Cores	RAM GB	OS	DB
	VIO x 2		2.0	48		
1	DC_REP_CI	95342	12.2	763	Compatible OS	DB2
2	PSBIWDB1	23836	3.1	191	Compatible OS	DB2
3	NEW_ECC_DB_FO	460606	59.1	3685	Compatible OS	DB2
		579784				
	<i>Summary Required</i>		76.3	4686		
	<i>Summary Configured</i>		80.0	5120		
12 x 12 Core RISC/EPIC Processor, (80 Cores Active), 5 TB RAM, 4 x 6 Slot Expn, 4 x 800G NVMe Disk / SAN boot						

Power Server - 3						
#	Lpar Name	SAPS	Cores	RAM GB	OS	DB
1	EHP_TEST	30000	6	200	AIX	DB2
2	ISUDEV_TEST	20000	4	200	AIX	DB2
3	NEW_BI_DB_PR	65000	13	360	AIX	DB2
4	NEW_BI_HADR	35000	7	196	AIX	DB2
5	NEW_BI_PREPROD	10000	2	56	AIX	DB2
6	NEW_GIS_FO	30000	6	168	AIX	DB2
7	NEW_MDAS_HADR	25000	5	140	AIX	DB2
8	NEW_MDAS_PR	30000	6	168	AIX	DB2
9	SAP_ECC_APP1	15000	3	70	AIX	DB2

10	SAP_ECC_APP3	15000	3	70	AIX	DB2
11	SAP_ECC_APP4	15000	3	70	AIX	DB2
12	SAP_ECC_APP5	15000	3	70	AIX	DB2
13	SAP_ECC_APP6	15000	3	70	AIX	DB2
14	SAP_ECC_APP7	15000	3	70	AIX	DB2
15	SAP_ECC_APP8	15000	3	70	AIX	DB2
16	P9_VIOS_1	5000	1	8	AIX	DB2
17	P9_VIOS_2	5000	1	8	AIX	DB2
18	BKP_PR	5000	1	15.38	AIX	DB2
19	ERP_BCS_REPLICA_DB	30453	6.1	268	AIX	DB2
20	ERP_REPLICA_DB	30453	6.1	268	AIX	DB2
21	PSECCAPP1	16252	3.3	143	AIX	DB2
22	PSECCAPP3	16252	3.3	143	AIX	DB2
23	ERP_SOLMGR	10834	2.2	95	AIX	DB2
24	SAP_BW_APP3	15227	3.0	134	AIX	DB2
		484471				
	<i>Summary Required</i>		96.9	3061		
	<i>Summary Configured</i>		127.0	3712.0		
9080-MHE-781FAF8						

Power Server - 4						
#	Lpar Name	SAPS	Cores	RAM GB	OS	DB
1	NEW_BI_DB_FO	65000	13	360	AIX	DB2
3	NEW_ECC_HADR	35000	7	196	AIX	DB2
4	NEW_ECC_PREPROD	10000	2	56	AIX	DB2
5	NEW_GIS_PR	30000	6	168	AIX	DB2
6	NEW_MDAS_FO	30000	6	168	AIX	DB2
7	P8_VIOS_1	5000	1	8	AIX	DB2
8	P8_VIOS_2	5000	1	8	AIX	DB2
7	BKP_FO	8375	2	15.38	AIX	DB2
8	ERP_BCS_REPLICA_CI	30453	6.1	268	AIX	DB2
9	ERP_REPLICA_CI	30453	6.1	268	AIX	DB2
10	PSECCAPP2	16252	3.3	143	AIX	DB2
11	ECC_APP2	30453	6.1	268	AIX	DB2
13	SAP_BW_APP2	15227	3.0	134	AIX	DB2
15	PSECCAPP4	16252	3.3	143	AIX	DB2
16	TSMSEVER	10834	2.2	95	AIX	DB2
17	SAP_BW_APP4	15227	3.0	134	AIX	DB2
		353525				

	<i>Summary Required</i>		71.0	2433		
	<i>Summary Configured</i>		91.0	2560.0		
9080-MHE-781FB18						

### Migrated Landscape DRC, Behrampore,

Server - 1						
#	Lpar Name	SAPS	Cores	RAM GB	OS	DB
	VIO x 2		2.0	48		
1	DC_REP_DB_CI	95342	12	763	Compatible OS	DB2
2	PSBIWCI1_DB	23836	3	191	Compatible OS	DB2
3	NEW_ECC_DB_PR_DR	460606	59	3685	Compatible OS	DB2
4	SAP_ECC_APP1	33499	2	70	Compatible OS	DB2
5	SAP_ECC_APP3	33499	2	70	Compatible OS	DB2
6	SAP_ECC_APP5	33499	2	70	Compatible OS	DB2
7	SAP_ECC_APP8	33499	2	70	Compatible OS	DB2
8	NEW_SAPECC_APP12	33499	2	70	Compatible OS	DB2
9	NEW_SAPECC_APP11	33499	2	70	Compatible OS	DB2
10	ECCAPP10	33499	2	70	Compatible OS	DB2
11		814274				
	<i>Summary Required</i>		90.3	5176		
	<i>Summary Configured</i>		96.0	6120		
12 x 12 Core RISC/EPIC Processor, (96 Cores Active), 6 TB RAM, , 4 x 6 Slot Exprn, 4 x 800G NVMe						

Power Server - 2						
#	Lpar Name	SAPS	Cores	RAM GB	OS	DB
	VIO x 2		2.0	48		
1	WBALDCFTP	8375	2	67	AIX	DB2
2	PSECCAPP5	17877	4	70	AIX	DB2
3	PSECCDEV1	11918	3	95	AIX	DB2
4	SAP_BW_APP5	16749	4	35	AIX	DB2
5	SAP_ECC_APP7	33499	7	70	AIX	DB2
6	NEW_SAPECC_APP9	33499	7	70	AIX	DB2
7	BKP_FO	8375	2	67	AIX	DB2
	ECC_APP2	33499	7	70	AIX	DB2
	SAP_ECC_APP4	33499	7	70	AIX	DB2
	SAP_BW_APP2	16749	4	35	AIX	DB2
11	SAP_ECC_APP6	33499	7	70	AIX	DB2
12	PSECCAPP4	17877	4	70	AIX	DB2
13	SAP_BW_APP4	16749	4	35	AIX	DB2
14	NEW_GIS_PR_DR	50248	5	140	AIX	DB2

15	NEW_MDAS_PR_DR	50248	5	140	AIX	DB2
	NEW_BI_DB_PR_DR	108870	20	280	AIX	DB2
17	BKP_PR	8375	1	16	AIX	DB2
	ERP_BCS_REPLICA_DB_CI	33499	2	50	AIX	DB2
	ERP_REPLICA_DB_CI	33499	2	100	AIX	DB2
	PSECCAPP1	17877	2	65	AIX	DB2
	SAP_BW_APP1	16749	2	35	AIX	DB2
	PSECCAPP3	17877	2	65	AIX	DB2
	ERP_SOLMGR	11918	2	95	AIX	DB2
	SAP_BW_APP3	16749	2	35	AIX	DB2
	PSECCAPP6	17877	2	65	AIX	DB2
	PSECCQA1	5959	1	48	AIX	DB2
	SAP_BW_APP6	16749	2	35	AIX	DB2
	TSMSEVER	11918	2	95	AIX	DB2
	PSECCAPP2	17877	2	65	AIX	DB2
	<i>Summary Required</i>		62.0	2202		
	<i>Summary Configured</i>		77.0	2432.0		
9080-MHE-781FB08   (Add) PHA - 1						

## 6.5.6 Post Migration Check.

### 6.5.6.1 Data integrity checks

Pre-migration and post-migration data sets should be compared for data non-integrity issues. Data integrity checks should check the following data parameters:

- i. Raw data integrity
- ii. Business rules / configuration rules
- iii. Data relations

Data integrity may be checked by using tools or manually by using various techniques like check digits, batch input totals, etc

### 6.5.6.2 Log Analysis for errors and mitigation

The Information Systems auditor should review the migration logs from data upload / transfer tools to check for errors in data migration. The logs should be verified for successful completion of the data migration as well as for any error messages like data sets getting corrupted or omitted, etc. Configuration and user setting logs should be extracted and compared with those of the earlier systems / applications. If any errors had been noticed by the migration team, the auditor should ask for the action taken report to find out whether the errors were rectified, and also check the mitigation steps taken to minimize the impact of such errors.

### 6.5.6.3 Performance review

Post-migration audit should review the performance of the new environment. The performance of the database, servers, applications, operating system, etc should be compared with the migration objectives as well as the premigration environment. Such an analysis assures the management that the migration objectives have been achieved.

For Network a VAPT must be conducted by a third party

All reports must be submitted by the IA to WBSEDCL milestone clearance.

### **6.5.7 User Acceptance Test and Final Acceptance Test**

Acceptance test by WBSEDCL will comprise of accepting each one of the supply criteria, implementation criteria, Migration criteria and training as mentioned in the respective sections.

**UAT team:** The User Acceptance team may comprise of members from WBSEDCL, its IT/OT Service Provider , Consultants and other stakeholders for this project.

**UAT Format:** the UAT format for each separate OEM would be decided during the documentation phase. However, in minimum, it will comprise of the criteria set forth in the Supply, Implementation, and migration phase above.

**UAT and FAT Times:** UAT will be conducted during the declaration of completion of each milestone. FAT will be conducted only once after the successful migration and before the Go Live.

**UAT Environment:** The pilot case, mentioned in each sections above will be first test environment. The next UAT environment will be the full environment before going live.

**UA Test Cases:** The test cases are as mentioned in each sections above.

**UAT Documentation:** IA to submit a clear documentation for the UAT and must comprise of feature, WBSEDCL acceptance criteria, the OEM output and the acceptance remarks of each stakeholder.

**Bug tracking and Resolution:** Implement a robust bug tracking system to capture and prioritize issues found during UAT. Define a process for reporting, tracking, and resolving bugs promptly.

**FAT:** As discussed above, it will be given as a final acceptance before the Go Live of the entire solution.

### **6.5.8 Go Live**

The "Go Live" phase after migrating to the revamped Data center is a critical stage in the project, where the newly migrated systems become operational. A well-defined strategy ensures a smooth transition and minimizes potential disruptions. IA to submit a Go Live strategy during documentation phase which shall comprise of

#### **Validation Testing:**

Before the actual Go Live, IA must conduct thorough validation testing to ensure that all systems, applications, and services function correctly in the new data center environment. This includes functional, performance, and security testing.

#### **Rollback Plan:**



IA must develop a rollback plan in case unexpected issues arise during the Go Live. This plan should detail the steps to revert to the previous state to minimize downtime and disruptions.

**Communication Plan:**

IA must establish a comprehensive communication plan that includes notifying all stakeholders, end-users, and support teams about the upcoming Go Live. They shall provide clear instructions on who to contact in case of issues and how to report them.

**Training and Documentation:**

IA shall ensure that relevant staff and end-users as delegated by WBSEDCL are trained on any changes related to the data center migration. Provide updated documentation and support resources to assist users during the transition.

**User Support and Helpdesk Readiness:**

IA shall train WBSEDCL helpdesk and support teams, ensuring they are well-prepared to handle an increased volume of inquiries during the Go Live. Monitor support channels closely and address issues promptly.

**Monitoring and Alerting:**

IA shall Implement robust monitoring and alerting systems to track the performance of critical systems and applications. Set up alerts for any unusual behavior or potential issues to enable proactive resolution.

**Incremental Go Live:**

IA shall consider a phased or incremental Go Live approach, as documented during the documentation phase.

**Contingency Planning:**

They shall identify potential risks and develop contingency plans for each. This includes power outages, network disruptions, or other unforeseen events.

**Performance Testing:**

IA must conduct performance and Load testing in a production-like environment to ensure that the infrastructure can handle the expected load. Identify and address any performance bottlenecks before the Go Live.

**Post-Go Live Stabilization Period:**

They shall have a dedicated support team available immediately after the Go Live to address any issues reported by end-users or system monitors for a period of two months. This team should be ready to provide quick resolutions and document any recurring issues for further analysis.

**Metrics and Key Performance Indicators (KPIs):**

IA shall define and monitor relevant metrics and KPIs to evaluate the success of the Go Live. This may include system uptime, response times, and user satisfaction surveys.

**Documentation of Changes:**

IA must document all changes made during the migration process. This includes configurations, settings, and any adjustments made to the systems in the new data center.

**Post-Implementation Review (PIR):**

They must conduct a post-implementation review to assess the success of the migration. Document lessons learned, identify areas for improvement, and use this information for future data center migration projects.

**Security Validation:**

IA must validate the security configurations and measures in the new data center. Ensure that firewalls, access controls, and other security mechanisms are functioning as expected.

**6.5.8.1 Go live Criteria Checklist:**

S.NO.	Activity*	Comments	Readiness Status/Score	Potential Impact/Changes
1.	Submission of documentations related to identified Project Deliverables			
2.	Submission of System Hardware and Software documents. Such as – OEM User Manuals, End-User License agreements, Warranty statements, etc.			
3.	Submission of User Documentation and system manuals, Standard Operating Procedure manuals, etc.			
4.	Completion of Supply, including hardware, Software before power ON			
5	IT Infrastructure commissioning and acceptance, after Power ON.			
6.	Completion of Software configurations as per WBSEDCL requirements			
7.	Completion of UAT as per Bid requirement			
7a.	Acceptance of supply and delivery of hardware components as per bid requirements			
7b.	Software (Virtualisation, Backup) solution commissioning and			

S.NO.	Activity*	Comments	Readiness Status/Score	Potential Impact/ Changes
	acceptance			
7c.	Completion of Network Migration			
7d.	Completion of Landscape Migration as per bid requirements			
8.	Submission of UAT Test Report			
9.	Training as per schedule approved by WBSEDCL			
10.	Change Management Process in Place as per WBSEDCL acceptance			
11.	Handover Plan Accepted by the WBSEDCL			
12.	Availability of detailed schedule for Go Live			
13.	Availability of Roll-back Plan			

### **6.6 Maintenance for IT Infrastructure**

Certain minimum deliverables sought from the Implementation Agency about System Maintenance and Management are provided below:

- i. The IA shall be responsible for tasks including but not limited to setting up servers, configuring and apportioning storage space, account management, performing periodic backup of data and automating reporting tasks, and executing hardware and software updates when necessary. It should be noted that the activities performed by the Implementation Agency will be under the supervision of WBSEDCL.
- ii. On an ongoing basis, the Implementation Agency shall be responsible for troubleshooting issues in the IT infrastructure solution to determine the areas where fixes are required and ensuring resolution of the same.
- iii. The Implementation Agency shall be responsible for identification, diagnosis, and resolution of problem areas pertaining to the IT Infrastructure and maintaining the defined SLA levels.
- iv. The Implementation Agency shall implement and maintain standard operating procedures for the maintenance of the IT infrastructure based on the policies formulated in discussion with WBSEDCL and based on the industry best practices/frameworks. The Implementation Agency shall also create and maintain adequate documentation/checklists or the same.
- v. The Implementation Agency should support the upgrade requirement (such as firmware upgrade, version upgrade, patch update, etc.) of the system.
- vi. Implementation Agency shall submit the OEM audit report along with OEM service escalation matrixes on quarterly basis upon submission of invoices.
- vii. In no case shall the maintenance cost of the supplied infrastructure and software must exceed 10% of the cost of supply, including the Hardware and Software.

### 6.6.1 Execution Period / Project Timeline

Project Implementation plan/Schedule is as follows:

Sr. No.	Milestone	Name of the activity	Timeline
1		Resource Mobilization	2 Weeks from LOI/LOA
2		As- Is study and preparation of To-be Documents comprising of HLDD, LLDD, IT Infra Landscape with H/W & N/W architecture and BOQ. IA needs to submit the required “As-Is” & “To-be” reports accordingly.	8 Weeks from LOI/LOA
3A	M1	Supply of Network Hardware/Software.	12 Weeks from LOI/LOA/
3B		Supply of Backup Device/ Software/License	15 Weeks from LOI/LOA/
3C	M2	Supply of Virtualisation Software, Server, Storage hardware.	20 Weeks from LOI/LOA/
4A		Installation Network Hardware/Software	26 Weeks from LOI/LOA
4B		Installation and Implementation of Backup Solution	30 weeks from LOI/LOA
4C	M3	Installation and Implementation of Virtualisation Software, Server, Storage hardware.	38 weeks from LOI/LOA
5	M4	Integration and Migration Services	50 Weeks from LOI/LOA
6	M5	User Acceptance Test and Go Live	52 Weeks from LOI/LOA
7	M6	Stabilisation Period of Two Months	60 Months from LOI/LOA
8		Warranty of the entire revamped Setup	3 years from Go Live

### 6.6.2 SLA during Maintenance Period.

Following is the summary of operations and maintenance services to be provided by the Implementation Agency to be performed under the supervision of WBSEDCL.

- a) Once deployed, the Implementation Agency is completely responsible for managing the entire support model to ensure the SLA uptime.
- b) Implementation Agency shall provide a comprehensive support basis to ensure an uptime % as mentioned below for the IT infrastructure solution in accordance with the Service Level Agreement mentioned as part of this tender.
- c) Implementation Agency shall commit to provide all necessary manpower resources to resolve any issues/incidents and carry out required changes, optimizations, and modifications.

- d) Implementation Agency shall provide comprehensive technical support services for all the hardware and software proposed for the entire period of the contract. The technical support should include all the upgrades, updates, and patches that are released by the respective OEMs during the period of the contract.
- e) At least one L1 resource need to be posted in each of DC and DRC during the entire tenure of warranty period of three years post Go Live. The minimum qualification of the posted resource must as per the details provided in section 6.7.10.
- f) The above L1 resource must be posted 24 X 7 who would monitor the operational parameters of DC Operation and must be responsible to liaison with the onsite FMS team or the OEM as and when required.
- g) SLA is to maintain and measured on a invoicing period basis by the IA and must be back to back with the OEM. Documents in proof of this needs to be presented to WBSEDCL on demand.
- h) SLA report signed by the IA and the WBSEDCL assigned personnel must be attached with the invoice raised for payment.

### 6.6.3 Penalties during Implementation and maintenance.

#### 6.6.3.1 Penalty For Delay in Project Implementation

For any delay in implementation of project (i.e., achieving Go-Live, as per definition of Go-Live as mentioned in the clause for "Execution Period"), a penalty @ 1/2% (Half percent) per week or part thereof plus GST of the "value of leftover un-commissioned/undelivered work and services" shall be levied / recovered.

However, the overall penalty for delay in the project implementation shall be capped at **5% (Plus GST@18%)** of the "value of leftover/undelivered work and services."

#### 6.6.3.2 Penalty during Warranty Period.

S. No	System	Measurement	Minimum Availability (in %)	Actual Availability (in %)	Deduction as % of Quarterly Charge
1	Compute Node	Availability of each Server.	99.995%	≥ 99 &<99.995	2% of Quarterly Charge
				≥ 98.5 &<99	4% of Quarterly Charge
				≥ 98.0 &<98.5	6% of Quarterly Charge
				<98.0	No Payment
2	Networking Components	Availability of Networking Components at DC and DRC	99.995%	≥ 99 &<99.995	2% of Quarterly Charge
				≥ 98.5 &<99	4% of Quarterly Charge
				≥ 98.0 &<98.5	6% of Quarterly Charge
				<98.0	No Payment
3	Storage System	Availability of Storage system at	99.995%	≥ 99 &<99.995	2% of Quarterly Charge
				≥ 98.5 &<99	4% of Quarterly Charge

		DC and DRC		≥ 98.0 &<98.5	6% of Quarterly Charge
				<98.0	No Payment
4	Backup System	Availability of each backup system	99.995%	≥ 99 &<99.995	2% of Quarterly Charge
				≥ 98.5 &<99	4% of Quarterly Charge
				≥ 98.0 &<98.5	6% of Quarterly Charge
				<98.0	No Payment

**Penalty based on response time:**

Service	Severity	Response Time (max)	Recovery Time (max)	Penalty beyond Recovery Time	Resolution Time (Max)	Penalty beyond Resolution Time
Compute Node	Severity 0	15 minutes	2 hours	@Rs.2500/ hr	1 day	@Rs.10000/Day
	Severity 1	2 hours	4 hours	@Rs.1000/ hr	2 days	@Rs.4000/Day
Networking Components	Severity 0	15 minutes	2 hours	@Rs.2500/ hr	1 day	@Rs.10000/Day
	Severity 1	2 hours	4 hours	@Rs.1000/ hr	2 days	@Rs.4000/Day
Storage System	Severity 0	15 minutes	2 hours	@Rs.2500/ hr	1 day	@Rs.10000/Day
	Severity 1	2 hours	4 hours	@Rs.1000/ hr	2 days	@Rs.4000/Day
Backup System	Severity 0	15 minutes	2 hours	@Rs.2500/ hr	1 day	@Rs.10000/Day
	Severity 1	2 hours	4 hours	@Rs.1000/ hr	2 days	@Rs.4000/Day

**Note:** - LD for Severity 0 and Severity 1 cannot be imposed simultaneously.

**Severity 0#:** - Complete specific Service Component is down, not working from secondary as well.

**Severity 1#:** - Service is up on redundant system but primary is down. **OR** Service is up on primary system but secondary is down.

Penalties for multiple parameters of Uptime, Response Time and Resolution Time will be added to arrive at the total penalty for all incidents for the quarter.

## 6.7 Tasks and Deliverables:

### 6.7.1 Assessment and Inventory:

- Conduct a comprehensive assessment of current infrastructure components, and IT Infra landscape (As-Is Study).
- Prepare an inventory report outlining the condition and specifications of existing servers, network devices, and storage systems.

### 6.7.2 Design and Planning:

- Develop a detailed plan, as part of To-Be document, in consultation with OEM for the consolidation and IT Infra upgrade process, including the necessary hardware and software requirements, system architecture, data migration strategy, and testing plan.
- Create architectural designs for the new infrastructure, ensuring modular and scalable features are incorporated.
- Detailed plan shall be approved by WBSEDCL before implementation.

### **6.7.3 Supply and Installation:**

- Supply and delivery the latest generation servers, network devices, and a scalable Storage System based on the approval & dispatch instructions of WBSEDCL, and as per specifications mentioned in this NIT.
- Install and configure the new infrastructure within the Data Center.
- The IT infra shall remain under valid OEM support during the entire period of the contract.

### **6.7.4 Delivery Conditions:**

1. WBSEDCL shall reserve its right for the Post Delivery Inspection of the IT Infra manufactured overseas before final installation. Moreover, the IA shall provide the reports and results of such tests carried out by OEMs as per the standard procedures for these devices, duly signed by the representative of the Implementation Agency & by the OEM, at the time of delivery & commissioning of material for its acceptance by WBSEDCL.
2. It will be the responsibility of the Implementation Agency to deliver the product and develop the IT Infra at Data Center meeting the requisite specifications of the RFP. An affidavit / undertaking declaring the same shall also be provided mentioning that Utility reserves its right to reject any good(s) that does not meet the desired specifications and performance at any point of project execution or its operation and the same shall be replaced by the Implementation Agency with proper products without any additional cost to WBSEDCL.
  - a. In compliance with the Ministry of Power Order No. 12/34/2020-T&R dated 07th Dec'2022 and similar other directives, the following shall also be submitted w.r.t the IT Infra:

*“All IT products procured /supplied shall have a valid Certificate of Common Criteria as per ISO/IEC 15408 issued by signatories of the Common Criteria Recognition Agreement (CCRA) or*

*Import/procurement/supplied from vendors sourcing from prior reference countries, the Certificate for Common Criteria shall be from Government Laboratories in India according to the IC3S scheme operated by Ministry of Electronics and Information Technology, which is a signatory to CCRA.”*

- b. The above shall however be without any prejudice to the rights of WBSEDCL to take any further recourse or remedy available in the matter to make good any loss to WBSEDCL and also in case of any dispute arising out of this matter with the Implementation Agency due to the delivery of any substandard/nonstandard items not confirming to the specifications of RFP under the project and becomes deterrent for the overall performance of the IT system.

### **6.7.5 Data Migration and Testing:**

- Migrate existing data and applications, duly upgraded to latest version, onto the new infrastructure with minimal downtime.
- Conduct rigorous testing to ensure functionality, security, and performance meet the organization's requirements.
- The following framework for the migration of existing data and applications to be followed:

Note: For Backup Management Pertaining to CC&B, GIS, MDAS Applications and similar other application, the Backup Software offered under the SOW shall also be used including DC-DR Drill.

### **6.7.5.1 Pre-Migration Phase: Inventory and Assessment:**

- Conduct a comprehensive inventory of existing data and applications, categorizing them based on criticality and interdependencies.
- Assess compatibility and requirements for migration to the new infrastructure.

### **Backup and Contingency Planning:**

- Perform a full backup of all data and applications to mitigate potential data loss during migration.
- Develop contingency plans to handle unforeseen issues or rollbacks in case of migration failure.

### **Resource Allocation:**

- Allocate necessary resources, including personnel, tools, and equipment, for the migration process.
- Coordinate with stakeholders to ensure their availability and support during migration.

### **6.7.5.2 Migration Execution: Detailed Migration Plan:**

- Develop a detailed step-by-step migration plan outlining specific tasks, timelines, and responsibilities.
- Prioritize migration sequences based on application dependencies and criticality.

### **Testing in a Controlled Environment:**

- Conduct thorough testing in a controlled environment to validate the migration process and identify potential issues.
- Ensure compatibility, functionality, and performance of applications on the new infrastructure.

### **Phased Migration Approach:**

- Implement a phased migration approach, prioritizing less critical applications initially to gauge the process's effectiveness.
- Gradually migrate critical applications, ensuring minimal disruption and verifying functionality at each step.

### **Real-time Monitoring and Validation:**

- Monitor the migration process in real-time to track progress and identify any anomalies or performance issues.
- Validate data integrity and application functionality post-migration.

### **6.7.5.3 Post-Migration:**

#### **Validation and User Acceptance Testing (UAT):**

- Engage stakeholders and end-users to conduct UAT on migrated applications to ensure their functionality and usability meet expectations.
- Address any identified issues or discrepancies promptly.



### **Documentation and Reporting:**

- Document the entire migration process, including challenges faced, solutions implemented, and outcomes achieved.
- Prepare a comprehensive report detailing the success criteria met, downtime incurred, and lessons learned for future reference.

### **Post-Migration Support:**

- Provide post-migration support to address any lingering issues or user queries related to the migrated data and applications.
- Ensure a transition period where support is readily available to resolve any migration-related concerns.

#### **6.7.5.4 Key Considerations:**

**Communication and Coordination:** Maintain clear communication channels among stakeholders, IT teams, and end-users throughout the migration process.

**Risk Mitigation:** Continuously assess risks and implement mitigation strategies to minimize the impact of potential disruptions.

**Rollback Plan:** Develop a rollback plan in case of critical issues, ensuring a swift return to the previous state without significant downtime or data loss.

The above SOP is intended to outline a structured approach for migrating data and applications to the new infrastructure while mitigating downtime. It emphasizes meticulous planning, thorough testing, phased execution, and post-migration support to ensure a smooth and successful transition with minimal disruptions to operations.

#### **6.7.6 Testing and Quality Assurance:**

Conduct thorough testing of the upgraded system to validate its performance, functionality, and integration with other systems. OEM consultation shall be taken during important phases of the project.

- vii. OEM Support features needed for IT as a service during the contract period:
  - i. Assigned Account team for WBSEDCL for personalized experience (relationship management)
  - ii. Account Support Manager (ASM)
  - iii. Technical Account Manager (TAM)
  - iv. Assigned WBSEDCL Engineer (ACE)
  - v. Account Support Plan - The ASM develops an account support plan in conjunction with the WBSEDCL's IT staff and documents the necessary combination of reactive and proactive support, devices, geographic coverage, and any other support aspects such as contact information and escalation procedures etc.
  - vi. Service Planning and Review - The ASM conducts quarterly (or the timeframe agreed in the Account Support Plan) onsite support planning and review sessions during which the WBSEDCL and the

ASM review the support provided by HPE over the previous period, including key topics arising from the support activity report and the outcome of Service activities. These reviews provide an opportunity to discuss trends, any planned changes to the WBSEDCL IT environment and business, and the impact of these changes on the WBSEDCL's support requirements. Any additional support requirements can also be identified and discussed.

vii. Support Activity Review – OEM provides WBSEDCL with a quarterly (or the timeframe agreed in the Account Support Plan) support-activity review report that documents reactive support-call information during that specific period.

viii. Inventory management & Environment profile (personalized experience) once in a year.

ix. Enhanced Incident Management -elevated support (priority access, with environmental awareness), rapid escalation through ASM for P1 incidents.

x. Operational & Technical Advice – IT infra-OEM takes an active role in providing advice and guidance regarding the routine delivery of the WBSEDCL's critical IT services

xi. Server firmware and software analysis – Quarterly (or as agreed in Account Support Plan) perform proactive server firmware gap analysis and provide recommendation in a detailed report, releases firmware updates for servers. These updates may address potential incidents, provide added functionality, or improve performance. Onsite/remote installation for recommended upgrades if WBSEDCL agree to provide necessary access to assigned engineer.

xii. Storage & SAN firmware and software analysis - On a quarterly basis (or the timeframe agreed in the Account Support Plan), OEM proactively analyses for potential storage-related software and firmware updates. The account team provides a recommendation as to applicable software and firmware updates as well as upgrade-planning assistance for the recommendations. OEM will install these updates, if requested by the WBSEDCL, either during standard business hours or outside standard business hours at no additional charge to the WBSEDCL. Storage calculation to be done on baies to run oracle and non oracle applications.

xvi. System Health Check – Yearly once, OEM should use diagnostic tools to assess the computing environment for a single operating system on a single physical server or partition. OEM can be requested to perform a series of diagnostic tests to compare the WBSEDCL's computing environment to accepted system management practices and provides a report that details the findings, highlighting the conditions that require resolution or investigation and recommending a suitable course of action.

## **6.7.7 Training**

The primary objective of the training is to achieve 100% user adoption of the Revamped System through technical and behavioral competencies covering all end users of WBSEDCL. Training shall be provided in English Language. The IA shall propose a training plan (including training curriculum and calendar) so that there is a proper transfer of knowledge about the deployed systems to utility staff and its FMS team. A Comprehensive Training Plan is to be submitted by the Implementation Agency during the documentation phase of the project.

**Audience:** WBSEDCL and its nominated delegates will attend the session. It may consist of WBSEDCL person or personnel outside of the organization.

**Advance Notice:** At least a weeks' notice is to be given for any training to be given by the IA.

**Venue:** All Trainings must be on site in the DC and the DRC. In no case the training may be online. The venue will be finalized by WBSEDCL.

**Trainer:** The trainer must be from the OEM of the supply. They must have hands-on knowledge of the topic covered by them.

**Attendance Sheet:** an attendance sheet must be put forward by the IA, at the time of UAT as a testimony to the trainings conducted.

**Content:** A book containing the materials to be trained by the trainer on the session must be handed over to each of the trainee. At least ten such study materials must be given.

General requirement for training to be imparted is as follows:

- 1) Training shall be conducted by IA personnel who are experienced instructors and speak understandable English language.
- 2) The IA shall provide training to various user groups nominated by WBSEDCL. The SI shall provide the Training Approach in the response.
- 3) All necessary training material shall be provided by the IA. Each trainee shall receive individual copies of documents used for training. Training material shall be organized by functional process that will serve as the training documentation for a functional area.
- 4) Training materials, including the documents provided to the trainees as well as handouts, shall become the property of WBSEDCL. Also, WBSEDCL reserves the right to copy such materials, but for in-house use only.
- 5) For all trainings the travel expenses will be borne by WBSEDCL for their own employees only.
- 6) The schedule, location, detailed contents, for each course shall be finalized during detail engineering. The number of participants in the training program may undergo change. However, the training courses shall preferably be conducted in single batch.
- 7) The training will consist of a curriculum of courses to address the issues of system operation, business-wide application, changed business processes and general use of the new system.
- 8) Representatives from the contractor, WBSEDCL's project management teams will be involved throughout in the development of training strategy, training material design and development, standards and training delivery to ensure that change management issues are incorporated, and that training strategies and materials are aligned to the requirements of the project and as business specific as possible.
- 9) WBSEDCL will have the option to cancel any or all training. In the case of cancellation, the rate quoted against the respective training will not be paid to the Contractor.

IA shall provide training sessions to all employees from lower level to higher level including officers from WBSEDCL on the domains listed in below table.

IA shall be required to organize following training for the WBSEDCL personnel: -

**Professional Training (Implementation team)**

This is the training for the core group of implementation team of WBSEDCL. The Implementation/Core team will comprise of members from /IT/Any Other domain of WBSEDCL. Each member would be trained in the relevant function/module. It is the responsibility of SI to deliver this training which shall include standard curriculum designed and agreed by WBSEDCL - hardware, software, communication infrastructure and network etc. The training should be arranged and conducted preferably by OEM partner or OEM's certified training partner for each group. WBSEDCL will prefer if a portion of the training is conducted on-site.

### **End User Training**

The SI will provide training to all end users of DC and DRC including hardware, software, communication infrastructure and network etc. This is the training for End users, Business users and staff of the WBSEDCL.

These training sessions will be required to be conducted at any of the DC or DRC sites. The recommended training material can be in paper / electronic media with courses on Business Process Automation software fundamentals, business process overview, job activity training, and delivery options being on-line, CBTs, instructor led classrooms, etc.

### **Content Development**

Development of customized, modular training materials based upon user roles and business process, and customized application. The IA will work together with WBSEDCL resources to enable transfer of knowledge. The following materials will be developed:

1. Paper-based classroom participant guides for each identified user group. These guides include hands-on exercises and are based upon 'Day in the Life' scenarios.
2. Paper-based classroom instructor guides including instructor notes with additional background information and points to be highlight during the training.
3. Media-based training simulations for pre-class preparation, in-class practicing and knowledge and skills validation.
4. SI can also be required to provide context sensitive on-line help, which includes all materials provided in the hard copy manuals. Where possible, users should be able to add their own on-line help documentation.

### **6.7.8 Secure Data Disposal for the buyback list of assets and Compliance:**

Secure data disposal is a critical process, especially when dealing with sensitive information associated with assets in a buyback list. This process is essential not only for protecting sensitive information but also for ensuring compliance with various laws and regulations regarding data protection and privacy. Here's a comprehensive approach to secure data disposal for WBSEDCL buyback list of assets:

#### **Understand the Data of WBSEDCL**

- **Inventory Assets:** Before disposal, IA must make a detailed inventory of all the assets. Understand what type of data is stored on each device, including personal, financial, or any sensitive business information.

- **Classification:** IA must classify the data based on its sensitivity and the potential risk its exposure could cause. This will help in determining the level of security needed during the disposal process.

#### **Data Disposal Policy**

- **Develop a Policy:** IA must create a data disposal policy under discussion with WBSEDCL that outlines how different types of data should be securely disposed of. This policy should comply with relevant data protection laws mentioned in Cybersecurity Guidelines mentioned below.
- **Regular Updates:** The policy should be reviewed and updated regularly to adapt to new threats, technologies, and changes in legal requirements.

#### **Methods of Secure Data Disposal**

- **Physical Destruction:** For physical assets like hard drives, CDs, or USBs, physical destruction must be used. This could involve shredding, crushing, or degaussing (for magnetic storage).
- **Data Wiping:** IA must use software tools to securely erase data from storage devices. This should be done in a way that the data cannot be recovered (e.g., using the DoD 5220.22-M standard for data wiping).
- **Encryption:** Encrypt data before deletion. If the encryption keys are securely destroyed, the data, even if recovered, will be unreadable.

#### **Documentation and Verification**

- **Certification of Destruction:** Obtain a certificate of destruction from the service provider if using a third-party service for physical destruction. This serves as proof of compliance with the data disposal policy.
- **Audit Trails:** Maintain detailed records of the disposal process, including what was disposed of, how, when, and by whom. These records are crucial for compliance audits and investigations.

#### **Third-Party Services**

- **Vetting:** If using third-party services for data disposal, ensure they are thoroughly vetted and comply with the necessary standards and regulations.
- **Contracts and Agreements:** Ensure contracts clearly state the expectations, methods of disposal, and compliance requirements to protect your data and meet regulatory obligations.

#### **Compliance Considerations**

Compliance with data protection and privacy laws is non-negotiable. Each jurisdiction may have its own requirements, but here are general principles to follow:

- **Data Minimization:** Keep only what is needed for as long as it is needed.
- **Transparency:** Be transparent about how you collect, use, and dispose of data.
- **Accountability:** Be able to demonstrate compliance with data protection laws and regulations, including secure disposal practices.

Secure data disposal is an ongoing process that requires attention to detail, regular updates to policies and procedures, and a commitment to training and awareness within your organization. By following these steps, you can ensure that your data disposal practices for buyback assets are secure and compliant.

#### **6.7.9 Unspecified Essential Work:**

- Any essential tasks or activities not explicitly mentioned in the SOW but deemed necessary for the successful accomplishment of the project objectives are included by default.

- This provision covers unforeseen but critical requirements that may emerge during the project lifecycle and are essential for meeting the project's goals.
- Allows for flexibility to accommodate unforeseen but critical tasks that may arise during the project execution phase.
- All passive cabling tasks within the Data Center are inherently part of the Scope of Work. Additionally, this provision is to ensure that any essential work not explicitly outlined in the SOW but vital for project success is included, providing flexibility and adaptability to meet unforeseen requirements during the project lifecycle.

### 6.7.10 Specifications of Onsite Resources

Resources of adequate skillset need to be posted onsite during the entire project. Apart from other resources required for successful completion of the project,

- A qualified Project Manager having requisite skillset and experience need to be posted onsite for managing day to day task of the upgrade.
- A Network and Security Subject Matter Expert and
- A Cloud and virtualization expert
- A Server and Storage Expert.

Need to be posted onsite. They must have

**Experience:** Minimum of four years of experience in the relevant skill with total 6 years of experience.

**Qualification:** An engineering graduate in from any recognized university.

**Certification:** Certification from the recognized institutions or from the OEM. (Mandatory).

### 6.7.11 Project Management

Prior to Project Implementation, the IA shall prepare and submit a detailed project implementation plan, in consultation with WBSEDCL, to ensure smooth takeover of existing Utility systems and any ongoing services under the scope of the Project.

**Project Implementation Plan would cover the following:**

- Understanding of WBSEDCL's requirement with respect to Project implementation.
- Overall system architecture;
- Details of proposed methodology;
- Schematic Diagram of Proposed System Configuration;
- Strategy for deployment of server, storage, networking, and other related components at DC and DRC and subsequent migration and Go-Live;
- Detailed bill of quantities for materials and services (including any special equipment) necessary to meet the technical specifications, functional & performance requirements;
- An approach paper documenting the interfaces for integration with existing and future applications based on the information provided by WBSEDCL;
- Project team structure;
- Governance framework;
- Resource planning and estimation;
- Risk planning;

- xii. Quality Assurance/ Quality Control of the Program (including Testing);
- xiii. Data Privacy Approach;
- xiv. Cyber Security Approach;
- xv. Repair and Maintenance Schedule including details on Spares Management;
- xvi. Training schedule;

### **Key Personnel**

The IA shall appoint at least the following personnel dedicated for the Project –

- a) **Project Manager:** She / he shall have the authority to make commitments and decisions that are binding on the IA. WBSEDCL will designate a Nodal officer to coordinate all project activities. All communications between WBSEDCL and the IA shall be coordinated through the project manager and nodal officer. The project manager should be an expert in managing Multivendor IT Services handling. The project managers shall be responsible for all communications between other members of the project staffs including sub-contractors, if any.
- b) **Network and Security Expert:** An expert in network and security covering application software, hardware and network installation, integration design and ability to manage multiple partners with different skill sets in different technology domains.
- c) **Virtualization and Cloud Expert:** An expert in Cloud and virtualization solutions covering hardware, software, and other related applications with experience in managing similar projects in other utility domains.
- d) **Server, Storage, and Migration Expert:** An expert in Server and Storage application hardware and software solutions with experience in lift-and-shift migration in similar projects in other utility domains.

The Project Manager shall be responsible for bringing in the various experts at the appropriate stage in the project as and when required.

### **Progress Report**

A progress report shall be prepared by the IA for each month against the activities listed in the project schedule. The report shall be made available to WBSEDCL on a monthly basis on a mutually agreed schedule, e.g., the 5th day of each month. The progress report shall include all the completed, ongoing and scheduled activities and transmittals issued and received for the month. The progress report will also highlight the risks to the project and plan for risk mitigation.

### **Transmittals**

Every document, letter, progress report, change order, and any other written transmissions exchanged between the IA and the WBSEDCL shall be assigned a unique transmittal number.

The IA shall maintain a correspondence index and assign transmittal numbers consecutively for all IA documents. WBSEDCL will maintain a similar correspondence numbering scheme identifying documents and correspondence that WBSEDCL initiates.

### **Review Meeting**

Progress meetings shall be scheduled by WBSEDCL and attended by the IA each reporting period to review progress of the project. Progress meetings shall be used to review the progress report, written correspondence exchanged since the last meeting, and open action items. The review meeting will also be used to discuss upcoming milestones, support needed from

WBSEDCL, risk identified by the Program team, risk mitigation strategies and to make decisions for path forward.

The IA shall also attend technical meetings as and when required by WBSEDCL to discuss technical aspects of the project and to review WBSEDCL comments on documents. When appropriate, these technical meetings shall be conducted as extensions to the progress meetings.

#### **Document Review and Approval Rights**

To ensure that the proposed systems conform to the specific provisions and general intent of the Specification, the IA shall submit documentation describing the systems to WBSEDCL for review and approval.

WBSEDCL will respond with written comments to the IA within Fifteen (15) calendar days after receipt of the documents. Documents requiring correction must be resubmitted by the IA to WBSEDCL within fifteen (15) calendar days. No Project Implementation Schedule relief is to be implied for documents requiring correction and resubmission to WBSEDCL.

WBSEDCL shall have the right to require the IA to make any necessary documentation changes at no additional cost to the Utility to achieve conformance with the Specification. To help WBSEDCL manage the review and approval of documents during any given period, the IA shall stagger the release of documents over the time allocated in the project schedule. The number and size of documents shall be factored into the document release schedule.

#### **Document Requirements**

List of documents to be provided by the IA to WBSEDCL over the entire Contract period has been provided in the NIT.



## **PART 3**

# **CONDITIONS OF CONTRACT AND CONTRACT FORMS**

## Section - 7 :Conditions of Contract

### Table ofContents

<b>PART 3.....</b>	<b>1</b>
<b>Section - 7 : Conditions of Contract .....</b>	<b>2</b>
General Conditions of Contract .....	6
A. Contract and Interpretation .....	6
<b>1. Definitions.....</b>	<b>6</b>
<b>2. Contract Documents .....</b>	<b>9</b>
<b>3. Interpretation .....</b>	<b>10</b>
<b>4. Communications .....</b>	<b>12</b>
<b>5. Law and Language.....</b>	<b>12</b>
<b>6. Fraud and Corruption.....</b>	<b>12</b>
B. Subject Matter of Contract.....	13
<b>7. Scope of Facilities.....</b>	<b>14</b>
<b>8. Time for Commencement and Completion .....</b>	<b>15</b>
<b>9. Contractor’s Responsibilities.....</b>	<b>15</b>
<b>10. Employer’s Responsibilities .....</b>	<b>17</b>
C. Payment.....	18
<b>11. Contract Price .....</b>	<b>18</b>
<b>12. Terms of Payment .....</b>	<b>19</b>
<b>13. Securities.....</b>	<b>19</b>
<b>14. Taxes and Duties .....</b>	<b>21</b>
D. Intellectual Property.....	21
<b>15. License/Use of Technical Information .....</b>	<b>21</b>
<b>16. Confidential Information .....</b>	<b>22</b>
E. Execution of the Facilities .....	23
<b>17. Representatives .....</b>	<b>23</b>

<b>18. Work Program .....</b>	<b>25</b>
<b>19. Subcontracting .....</b>	<b>27</b>
<b>20. Design and Engineering.....</b>	<b>28</b>
<b>21. Procurement .....</b>	<b>31</b>
<b>22. Installation .....</b>	<b>33</b>
<b>23. Test and Inspection .....</b>	<b>41</b>
<b>24. Precommissioning, Commissioning, Guarantee Tests and Completion of the Facilities .....</b>	<b>43</b>
<b>25. Operational Acceptance .....</b>	<b>49</b>
F. Guarantees and Liabilities.....	50
<b>26. Completion Time Guarantee .....</b>	<b>50</b>
<b>27. Defect Liability .....</b>	<b>51</b>
<b>28. Functional Guarantees .....</b>	<b>54</b>
<b>29. Patent Indemnity.....</b>	<b>56</b>
<b>30. Limitation of Liability .....</b>	<b>57</b>
G. Risk Distribution.....	58
<b>31. Transfer of Ownership .....</b>	<b>58</b>
<b>32. Care of Facilities .....</b>	<b>59</b>
<b>33. Loss of or Damage to Property; Accident or Injury to Workers; Indemnification..</b>	<b>60</b>
<b>34. Insurance .....</b>	<b>61</b>
<b>35. Unforeseen Conditions.....</b>	<b>67</b>
<b>36. Change in Laws and Regulations .....</b>	<b>68</b>
<b>37. Force Majeure .....</b>	<b>69</b>
<b>38. War Risks .....</b>	<b>71</b>
H. Change in Contract Elements.....	72
<b>39. Change in the Facilities .....</b>	<b>73</b>
<b>40. Extension of Time for Completion .....</b>	<b>73</b>
<b>41. Suspension .....</b>	<b>75</b>

<b>42. Termination</b> .....	<b>77</b>
<b>43. Assignment</b> .....	<b>84</b>
I. Claims, Disputes and Arbitration.....	84
<b>44. Contractor’s Claims</b> .....	<b>84</b>
<b>45. Disputes and Arbitration</b> .....	<b>86</b>
J. Additional .....	88
<b>46. Up-front intimation of approved manufacturers and criterion for Fresh Vendor approval</b> .....	<b>88</b>
<b>47. Up-front intimation of Guaranteed Technical Particulars</b> .....	<b>88</b>
<b>48. Turnkey Contractor’s Store at Project site</b> .....	<b>88</b>
<b>49. Handing over of assets</b> .....	<b>89</b>
<b>50. Supply of Materials in lots</b> .....	<b>90</b>
<b>51.Contract Closing</b> .....	<b>90</b>
<b>52. Suspension of business dealings</b> .....	<b>91</b>
Special Conditions of Contract .....	97
<b>Section - 8 : Contract Forms</b> .....	<b>104</b>
2. BID SECURITY FORM.....	105
3a. FORM OF NOTIFICATION BY THE EMPLOYER TO THE BANK.....	108
3b. FORM OF NOTIFICATION BY THE EMPLOYER TO THE BANK.....	109
4. FORM OF ‘NOTIFICATION OF AWARD OF CONTRACT’ .....	110
5. FORM OF CONTRACT AGREEMENT .....	120
[Alternative – a] .....	120
[Alternative – b].....	126
Appendix-1: TERMS AND PROCEDURES OF PAYMENT .....	133
Appendix-2 : PRICE ADJUSTMENT .....	136
Appendix-3 : INSURANCE REQUIREMENTS.....	152
Appendix-4 : TIME SCHEDULE.....	157
Appendix-5 : LIST OF APPROVED SUBCONTRACTORS .....	158
Appendix-6 : SCOPE OF WORKS AND SUPPLY BY THE EMPLOYER .....	159
Appendix-7 : LIST OF DOCUMENTS FOR APPROVAL OR REVIEW .....	160
Appendix-8 : GUARANTEES, LIQUIDATED DAMAGES FOR NON – PERFORMANCE .....	161
6. PERFORMANCE SECURITY FORM .....	162
7. BANK GUARANTEE FORM FOR ADVANCE PAYMENT .....	166
8. FORM OF COMPLETION CERTIFICATE .....	169
9. FORM OF INDEMNITY BOND TO BE EXECUTED BY THE CONTRACTOR FOR THE EQUIPMENT HANDED OVER IN ONE LOT BY WBSOEDCL FOR PERFORMANCE OF ITS CONTRACT .....	170

10. FORM OF INDEMNITY BOND TO BE EXECUTED BY THE CONTRACTOR FOR THE EQUIPMENT HANDED OVER IN INSTALLMENTS BY WBSEDCL FOR PERFORMANCE OF ITS CONTRACT .....	174
11. FORM OF AUTHORISATION LETTER.....	178
12. FORM OF TRUST RECEIPT FOR PLANT, EQUIPMENT AND MATERIALS RECEIVED.....	180
13. FORM OF EXTENSION OF BANK GUARANTEE.....	181
14. FORM OF POWER OF ATTORNEY FOR JOINT VENTURE(JV).....	183
15. FORM OF UNDERTAKING BY THE JOINT VENTURE(JV) PARTNERS .....	185
16. FORMAT FOR EVIDENCE OF ACCESS TO OR AVAILABILITY OF CREDIT/FACILITIES.....	190
17. FORM OF OPERATIONAL ACCEPTANCE.....	192
18. FORM OF SAFETY PLAN TO BE SUBMITTED BY THE CONTRACTOR WITHIN SIXTY DAYS OF AWARD OF CONTRACT .....	193
19. FORM OF JOINT DEED OF UNDERTAKING BY THE SUB-CONTRACTOR ALONGWITH THE CONTRACTOR .....	210
20. FORM OF CERTIFICATE OF FINANCIAL PARAMETERS FOR QR .....	213
21. PROFORMA OF INDEMNITY BOND TO BE EXECUTED BY THE CONTRACTOR FOR THE COVERAGE AGAINST LATENT DEFECT.....	225

## General Conditions of Contract

### A. Contract and Interpretation

#### 1. Definitions

1.1 The following words and expressions shall have the meanings hereby assigned to them:

“Contract” means the Contract Agreement entered into between the Employer and the Contractor in accordance with the mode of contracting as per **SCC**, together with the Contract Documents referred to therein; they shall constitute the Contract, and the term “the Contract” shall in all such documents be construed accordingly.

“Contract Documents” means the documents listed in Article 1.1 (Contract Documents) of the Contract Agreement (including any amendments thereto).

“GCC” means the General Conditions of Contract hereof.

“SCC” means the Special Conditions of Contract.

“day” means calendar day.

“year” means 365 days.

“month” means calendar month.

“Party” means the Employer or the Contractor, as the context requires, and “Parties” means both of them.

“Employer” means the person named as such in the **SCC** and includes the legal successors or permitted assigns of the Employer.

“Project Manager” means the person appointed by the Employer in the manner provided in GCC Sub-Clause 17.1 (Project Manager) hereof and named as such in the **SCC** to perform the duties delegated by the Employer.

“Contractor” means the person(s) whose Bid to perform the Contract has been accepted by the Employer and is named as Contractor in the Contract Agreement, and includes the legal successors or permitted assigns of the Contractor.

“Contractor’s Representative” means any person nominated by the Contractor and approved by the Employer in the manner provided in GCC Sub-Clause 17.2 (Contractor’s Representative and Construction Manager) hereof to perform the duties delegated by the Contractor.

“Construction Manager” means the person appointed by the Contractor’s Representative in the manner provided in GCC Sub-Clause 17.2.4.

“SubContractor,” including manufacturers, means any person to whom execution of any part of the Facilities, including preparation of any design or supply of any Plant, is sub-contracted directly or indirectly by the Contractor, and includes its legal successors or permitted assigns.

“Contract Price” means the sum specified in Article 2.1 (Contract Price) of the Contract Agreement, subject to such additions and adjustments thereto or deductions therefrom, as may be made pursuant to the Contract.

“Facilities” (alternatively referred to as the “Works”) means the Plant to be supplied and installed, as well as all the Installation Services to be carried out by the Contractor under the Contract.

“Plant” means permanent plant, equipment, machinery, apparatus, goods, materials, articles and things of all kinds to be provided and incorporated in the Facilities by the Contractor under the Contract (including the spare parts to be supplied by the Contractor under GCC Sub-Clause 7.3 hereof), but does not include Contractor’s Equipment.

“Installation Services” means all those services ancillary to the supply of the Plant for the Facilities, to be provided by the Contractor under the Contract, such as transportation and provision of marine or other similar insurance, inspection, expediting, site preparation works (including the provision and use of Contractor’s Equipment and the supply of all construction materials required), installation, testing, precommissioning, commissioning, operations, maintenance, the provision of operations and maintenance manuals, training, etc. as the case may require.

“Contractor’s Equipment” means all facilities, equipment, machinery, tools, apparatus, appliances or things of every kind required in or for installation, completion and maintenance of Facilities that are to be provided by the Contractor, but does not include Plant, or other things intended to form or forming part of the Facilities.

“Site” (alternatively referred to as the “ Project Site”) means the land and other places upon which the Facilities are to be installed, and such other land or places as may be specified in the Contract as forming part of the Site.

“Effective Date” means the date of fulfillment of all conditions stated in Article 3 (Effective Date) of the Contract Agreement, from which the Time for Completion shall be counted.

“Time for Completion” means the time within which Completion of the Facilities as a whole (or of a part of the Facilities where a separate Time for Completion of such part has been prescribed) is to be attained, as referred to in GCC Clause 8 and in accordance with the relevant provisions of the Contract.

“Completion” means that the Facilities (or a specific part thereof where specific parts are specified in the Contract) have been completed operationally and structurally and put in a tight and clean condition, that all work in respect of Precommissioning, Guarantee Test, Commissioning and Asset Tagging on the GIS Portal of the Facilities or such specific part thereof has been completed as provided in GCC Clause 24 (Precommissioning, Commissioning, Guarantee Tests and Completion of Facilities) hereof.

“Precommissioning” means the testing, checking and other requirements specified in the Employer’s Requirements that are to be carried out by the Contractor in preparation for Commissioning as provided in GCC Clause 24 (Precommissioning, Commissioning, Guarantee Tests and Completion of Facilities) hereof.

“Commissioning” means operation of the Facilities or any part thereof by the Contractor following Precommissioning, which operation is to be carried out by the Contractor as provided in GCC Clause 24



(Precommissioning, Commissioning, Guarantee Tests and Completion of Facilities) hereof, for the purpose of carrying out Guarantee Test(s).

“Guarantee Test(s)” means the test(s) specified in the Employer’s Requirements to be carried out to ascertain whether the Facilities or a specified part thereof is able to attain the Functional Guarantees specified in the Appendix to the Contract Agreement titled Functional Guarantees, in accordance with the provisions of GCC Clause 24 (Precommissioning, Commissioning, Guarantee Tests and Completion of Facilities) hereof.

“Operational Acceptance” means the acceptance by the Employer of the Facilities (or any part of the Facilities where the Contract provides for acceptance of the Facilities in parts), which certifies the Contractor’s fulfillment of the Contract in respect of Functional Guarantees of the Facilities (or the relevant part thereof) in accordance with the provisions of GCC Clause 28 (Functional Guarantees) hereof and shall include deemed acceptance in accordance with GCC Clause 25 (Operational Acceptance) hereof.

“Defect Liability Period” means the period of validity of the warranties given by the Contractor commencing at Completion of the Facilities or a part thereof, during which the Contractor is responsible for defects with respect to the Facilities (or the relevant part thereof) as provided in GCC Clause 27 (Defect Liability) hereof.

“System Integrator” or “SI”, means the responsible implementation agency named in SCC appointed by Utility for implementing the DC/DRC infrastructure upgradation upon execution of the Contract subsequent to the Letter of Award referred to in SCC;

## **2. Contract Documents**

- 2.1 Subject to Article 1.2 (Order of Precedence) of the Contract Agreement, all documents forming part of the Contract (and all parts thereof) are intended to be correlative, complementary and mutually explanatory. The Contract shall be read as a whole.

### 3. Interpretation

3.1 In the Contract, except where the context requires otherwise:

- (a) words indicating one gender include all genders;
- (b) words indicating the singular also include the plural and words indicating the plural also include the singular;
- (c) provisions including the word “agree,” “agreed,” or “agreement” require the agreement to be recorded in writing;
- (d) the word “tender” is synonymous with “Bid,” “tenderer,” with “Bidder,” and “tender documents” with “Bidding Document,” and
- (e) “written” or “in writing” means hand-written, type-written, printed or electronically made, and resulting in a permanent record.

The marginal words and other headings shall not be taken into consideration in the interpretation of these Conditions.

#### 3.2 Incoterms

Unless inconsistent with any provision of the Contract, the meaning of any trade term and the rights and obligations of Parties thereunder shall be as prescribed by *Incoterms*.

Incoterms means international rules for interpreting trade terms published by the International Chamber of Commerce (latest edition), 38 Cours Albert 1<sup>er</sup>, 75008 Paris, France.

#### 3.3 Entire Agreement

Subject to GCC Sub-Clause 16.4 hereof, the Contract constitutes the entire agreement between the Employer and Contractor with respect to the subject matter of Contract and supersedes all communications, negotiations and agreements (whether written or oral) of Parties with respect thereto made prior to the date of Contract.

#### 3.4 Amendment

No amendment or other variation of the Contract shall be effective unless it is in writing, is dated, expressly refers to the Contract, and is signed.

### 3.5 Independent Contractor

The Contractor shall be an independent Contractor performing the Contract. The Contract does not create any agency, partnership, Joint Venture(JV) or other joint relationship between the Parties hereto. Subject to the provisions of the Contract, the Contractor shall be solely responsible for the manner in which the Contract is performed. All employees, representatives or SubContractors engaged by the Contractor in connection with the performance of the Contract shall be under the complete control of the Contractor and shall not be deemed to be employees of the Employer, and nothing contained in the Contract or in any subcontract awarded by the Contractor shall be construed to create any contractual relationship between any such employees, representatives or SubContractors and the Employer.

### 3.6 Non-Waiver

3.6.1 Subject to GCC Sub-Clause 3.6.2 below, no relaxation, forbearance, delay or indulgence by either Party in enforcing any of the terms and conditions of the Contract or the granting of time by either Party to the other shall prejudice, affect or restrict the rights of that Party under the Contract, nor shall any waiver by either Party of any breach of Contract operate as waiver of any subsequent or continuing breach of Contract.

3.6.2 Any waiver of a Party's rights, powers or remedies under the Contract must be in writing, must be dated and signed by an authorized representative of the Party granting such waiver, and must specify the right and the extent to which it is being waived.

### 3.7 Severability

If any provision or condition of the Contract is prohibited or rendered invalid or unenforceable, such prohibition, invalidity or unenforceability shall not

affect the validity or enforceability of any other provisions and conditions of the Contract.

### 3.8 Country of Origin

“Origin” means the place where the plant and component parts thereof are mined, grown, produced or manufactured, and from which the services are provided. Plant components are produced when, through manufacturing, processing, or substantial or major assembling of components, a commercially recognized product results that is substantially in its basic characteristics or in purpose or utility from its components.

## 4. Communications

4.1 Wherever these Conditions provide for the giving or issuing of approvals, certificates, consents, determinations, notices, requests and discharges, these communications shall be:

- (a) in writing and delivered against receipt; and
- (b) delivered, sent or transmitted to the address for the recipient’s communications as stated in the Contract Agreement.

1.1 When a certificate is issued to a Party, the certifier shall send a copy to the other Party. When a notice is issued to a Party, by the other Party or the Project Manager, a copy shall be sent to the Project Manager or the other Party, as the case may be.

## 5. Law and Language

5.1 The Contract shall be governed by and interpreted in accordance with laws of India including any other instruments having the force of law in India, as they may be issued and in force from time to time.

5.2 The ruling language of the Contract shall be English.

5.3 The language for communications shall be the ruling language unless otherwise stated in the **SCC**.

## 6. Fraud and Corruption

6.1 The Employer requires compliance with the stipulations on Fraud and Corruption, as set forth in the Attachment 1 to the GCC and the Integrity Pact if applicable as per **SCC**.

## **B. Subject Matter of Contract**

## 7. Scope of Facilities

- 7.1 Unless otherwise expressly limited in the Employer's Requirements, the Contractor's obligations cover the provision of all Plant and the performance of all Installation Services required for the design, and the manufacture (including procurement, quality assurance, construction, installation, associated civil works, Precommissioning and delivery) of the Plant, and the installation, completion and Commissioning of the Facilities in accordance with the plans, procedures, specifications, drawings, codes and any other documents as specified in the Section, Employer's Requirements. Such specifications include, but are not limited to, the provision of supervision and engineering services; the supply of labor, materials, equipment, spare parts (as specified in GCC Sub-Clause 7.3 below) and accessories; Contractor's Equipment; construction utilities and supplies; temporary materials, structures and facilities; transportation (including, without limitation, unloading and hauling to, from and at the Site); and storage, except for those supplies, works and services that will be provided or performed by the Employer, as set forth in the Appendix to the Contract Agreement titled Scope of Works and Supply by the Employer.
- 7.2 The Contractor shall, unless specifically excluded in the Contract, perform all such work and/or supply all such items and materials not specifically mentioned in the Contract but that can be reasonably inferred from the Contract as being required for attaining Completion of the Facilities as if such work and/or items and materials were expressly mentioned in the Contract. No extra payment shall be made for these additional accessories or materials required.
- 7.3 In addition to the supply of Mandatory Spare Parts included in the Contract, the Contractor agrees to supply spare parts required for the operation and maintenance of the Facilities for the period specified in the SCC and the provisions, if any, specified in the SCC. However, the identity, specifications and quantities of such spare parts and the terms and conditions relating to the supply thereof are to be agreed between the Employer and the Contractor, and the price of such spare parts shall be that given in Price Schedule No. 4, which shall be added to the

Contract Price. The price of such spare parts shall include the purchase price therefor and other costs and expenses (including the Contractor's fees) relating to the supply of spare parts.

## **8. Time for Commencement and Completion**

8.1 The Contractor shall commence work on the Facilities within the period specified in the SCC and without prejudice to GCC Sub-Clause 26.2 hereof, the Contractor shall thereafter proceed with the Facilities in accordance with the time schedule specified in the Appendix to the Contract Agreement titled Time Schedule.

8.2 The Contractor shall attain Completion of the Facilities or of a part where a separate time for Completion of such part is specified in the Contract, within the time stated in the SCC or within such extended time to which the Contractor shall be entitled under GCC Clause 40 hereof.

## **9. Contractor's Responsibilities**

9.1 The Contractor shall design, manufacture including associated purchases and/or subcontracting, install and complete the Facilities in accordance with the Contract. When completed, the Facilities should be fit for the purposes for which they are intended as defined in the Contract.

9.2 The Contractor confirms that it has entered into this Contract on the basis of a proper examination of the data relating to the Facilities including any data as to boring tests provided by the Employer, and on the basis of information that the Contractor could have obtained from a visual inspection of the Site if access thereto was available and of other data readily available to it relating to the Facilities as of the date twenty-eight (28) days prior to Bid submission. The Contractor acknowledges that any failure to acquaint itself with all such data and information shall not relieve its responsibility for properly estimating the difficulty or cost of successfully performing the Facilities.

9.3 The Contractor shall acquire and pay for all permits, approvals and/or licenses which are not covered under GCC Clause 10.3 Employer's Responsibility from all local, state or national government authorities or public service undertakings in relevant to where the Site is located, which such authorities or undertakings require the Contractor to obtain in

its name and which are necessary for the performance of the Contract, including, without limitation, permits/ certificates if needed for the Contractor's and SubContractor's personnel and entry permits for all Contractor's Equipment.

- 9.4 The Contractor shall comply with all laws in force in India including any instruments having the force of law. The laws will include all local, state, national or other laws that affect the performance of the Contract and bind upon the Contractor. The Contractor shall indemnify and hold harmless the Employer from and against any and all liabilities, damages, claims, fines, penalties and expenses of whatever nature arising or resulting from the violation of such laws by the Contractor or its personnel, including the SubContractors and their personnel, but without prejudice to GCC Sub-Clause 10.1 hereof.
- 9.5 Any Plant and Installation Services that will be incorporated in or be required for the Facilities and other supplies shall have their origin which do not violate the provisions of any Orders/ Circulars or other instruments issued by the Government that are in force. Any subContractors retained/ engaged by the Contractor in accordance with the provisions of the Contract, shall not violate the provisions of any Orders/ Circulars or other instruments issued by the Government that are in force.
- 9.6 If the Contractor is a Joint Venture(JV), or association (JOINT VENTURE(JV)) of two or more persons, all such persons shall be jointly and severally bound to the Employer for the fulfillment of the provisions of the Contract, and shall designate one of such persons to act as a leader with authority to bind the JOINT VENTURE(JV). The composition or the constitution of the Joint Venture(JV) shall not be altered without the prior written consent of the Employer.
- 9.7 Protection of the Environment
- (a) The Contractor shall take all reasonable steps to protect the environment (both on and off the Site) and to limit damage and nuisance to people and property resulting from pollution, noise, and other results of his operations.
- (b) The Contractor shall ensure that emissions, surface discharges, and effluent from the Contractor's



activities shall not exceed the values stated in the Specification or prescribed by applicable Laws.

## **10. Employer's Responsibilities**

- 10.1 All information and/or data to be supplied by the Employer as described in the Appendix to the Contract Agreement titled Scope of Works and Supply by the Employer, shall be deemed to be accurate, except when the Employer expressly states otherwise.
- 10.2 The Employer shall be responsible for acquiring and providing legal and physical possession of the Site and access thereto, and for providing possession of and access to all other areas reasonably required for the proper execution of the Contract, including all requisite rights of way, as specified in the Appendix to the Contract Agreement titled Scope of Works and Supply by the Employer. The Employer shall give full possession of and accord all rights of access thereto on or before the date(s) specified in that Appendix.
- 10.3 The Employer shall acquire and pay for all permits, approvals and/or licenses from all local, state or national government authorities or public service undertakings in the country where the Site is located which (a) such authorities or undertakings require the Employer to obtain in the Employer's name, (b) are necessary for the execution of the Contract, including those required for the performance by both the Contractor and the Employer of their respective obligations under the Contract, and (c) are specified in the Appendix (Scope of Works and Supply by the Employer). Such expenditure incurred by the Employer shall be booked as a part of the project cost, within the overall sanctioned costs under the scheme.
- 10.4 If requested by the Contractor, the Employer shall use its best endeavors to assist the Contractor in obtaining in a timely and expeditious manner all permits, approvals and/or licenses necessary for the execution of the Contract from all local, state or national government authorities or public service undertakings that such authorities or undertakings require the Contractor or SubContractors or the personnel of the Contractor or SubContractors, as the case may be, to obtain.

- 10.5 Unless otherwise specified in the Contract or agreed upon by the Employer and the Contractor, the Employer shall provide sufficient, properly qualified operating and maintenance personnel; shall supply and make available all utilities and facilities; and shall perform all work and services of whatsoever nature, including those required by the Contractor to properly carry out Precommissioning, Commissioning and Guarantee Tests, all in accordance with the provisions of the Appendix to the Contract Agreement titled Scope of Works and Supply by the Employer, at or before the time specified in the program furnished by the Contractor under GCC Sub-Clause 18.2 hereof and in the manner thereupon specified or as otherwise agreed upon by the Employer and the Contractor.
- 10.6 The Employer shall be responsible for the continued operation of the Facilities after issuance of Completion certificate, in accordance with GCC Sub-Clause 24.
- 10.7 All costs and expenses involved in the performance of the obligations under this GCC Clause 10 shall be the responsibility of the Employer, save those to be incurred by the Contractor with respect to the performance of Guarantee Tests and Commissioning, in accordance with GCC Clause 24.
- 10.8 In the event that the Employer shall be in breach of any of his obligations under this Clause, the additional cost/ compensation, if any, payable to the Contractor in consequence be determined by the Project Manager of the respective project office in the district.

## **C. Payment**

### **11. Contract Price**

- 11.1 The Contract Price shall be as specified in Article 2 (Contract Price and Terms of Payment) of the Contract Agreement.
- 11.2 Unless an adjustment clause is provided for in the SCC, the Contract Price shall be a firm not subject to any alteration, except in the event of a Change in the Facilities or as otherwise provided in the Contract.
- 11.3 Subject to GCC Sub-Clauses 9.2, 10.1 and 35 hereof, the Contractor shall be deemed to have satisfied itself as to the correctness and sufficiency of the Contract

Price, which shall, except as otherwise provided for in the Contract, cover all its obligations under the Contract.

## **12. Terms of Payment**

- 12.1 The Contract Price shall be paid as specified in Article 2 (Contract Price and Terms of Payment) of the Contract Agreement and in the Appendix to the Contract Agreement titled Terms and Procedures of Payment, which also outlines the procedures to be followed in making application for and processing payments.
- 12.2 No payment made by the Employer herein shall be deemed to constitute acceptance by the Employer of the Facilities or any part(s) thereof.
- 12.3 In the event that the Employer fails to make any payment by its respective due date or within the period set forth in the Contract, the Employer shall pay to the Contractor interest on the amount of such delayed payment at the rate(s) shown in the Appendix to the Contract Agreement titled Terms and Procedures of Payment, for the period of delay until payment has been made in full, whether before or after judgment or arbitration award.
- 12.4 The currency or currencies in which payments are made to the Contractor under this Contract shall be specified in the Appendix to the Contract Agreement titled Terms and Procedures of Payment, subject to the general principle that payments will be made in the currency or currencies in which the Contract Price has been stated.
- 12.5 Deleted.

## **13. Securities**

### **13.1 Issuance of Securities**

The Contractor/Bidder shall provide the securities specified below in favor of the Employer at the times, and in the amount, manner and form specified below.

### **13.2 Advance Payment Security**

13.2.1 The Contractor/Bidder shall, within twenty-eight (28) days of the notification of contract award, provide a security in an amount equal to 100% of the advance payment calculated in accordance with the Appendix to the Contract

Agreement titled Terms and Procedures of Payment, and in the same currency or currencies.

13.2.2 The security shall be in the form provided in the Bidding documents or in another form acceptable to the Employer. The amount of the security shall be reduced in proportion to the value of the Facilities executed by and paid to the Contractor/Bidder from time to time, and shall automatically become null and void when the full amount of the advance payment has been recovered by the Employer. The security shall be returned to the Contractor/Bidder immediately after its expiration.

### 13.3 Performance Security

13.3.1 The Contractor/Bidder shall, within twenty-eight (28) days of the notification of contract award, provide a security for the due performance of the Contract in the amount specified in the **SCC**.

13.3.2 The Performance Security shall be denominated in the currency or currencies of the Contract, and shall be in the form provided in Section 8, Contract Forms, corresponding to the type of bank guarantee stipulated by the Employer in the **SCC**, or in another form acceptable to the Employer.

13.3.3 Unless otherwise specified in the SCC, the security shall be reduced by half on the date of the Operational Acceptance. The Security shall become null and void, or shall be reduced pro rata to the Contract Price of a part of the Facilities for which a separate Time for Completion is provided, 540 days after Completion of the Facilities or 365 days after Operational Acceptance of the Facilities, whichever occurs first; provided, however, that if the Defect Liability Period has been extended on any part of the Facilities pursuant to GCC Subclause 27.8 hereof, the Contractor shall issue an additional security in an amount proportionate to the Contract Price of that part. The security shall be returned to the Contractor immediately after its expiration, provided, however, that if the Contractor,

pursuant to GCC Subclause 27.10, is liable for an extended defect liability obligation, the performance security shall be extended for the period and up to the amount specified in the SCC.

#### **14. Taxes and Duties**

14.1 Except as otherwise specifically provided in the Contract, the Contractor shall bear and pay all taxes, duties, levies and charges assessed on the Contractor, its SubContractors or their employees by all municipal, state or national government authorities in connection with the Facilities in and outside of the country where the Site is located.

14.2 Notwithstanding GCC Sub-Clause 14.1 above, the Employer shall pay/reimburse to the Contractor, the taxes and duties, if any, specified in SCC.

### **D. Intellectual Property**

#### **15. License/Use of Technical Information**

15.1 For the operation and maintenance of the Plant, including procurement of future spares, the Contractor hereby grants a non-exclusive and non-transferable license (without the right to sub-license) to the Employer under the patents, utility models or other industrial property rights owned by the Contractor or by a third Party from whom the Contractor has received the right to grant licenses thereunder, and shall also grant to the Employer a non-exclusive and non-transferable right (without the right to sub-license) to use the know-how and other technical information disclosed to the Employer under the Contract. Nothing contained herein shall be construed as transferring ownership of any patent, utility model, trademark, design, copyright, know-how or other intellectual property right from the Contractor or any third Party to the Employer.

15.2 The copyright in all drawings, documents and other materials containing data and information furnished to the Employer by the Contractor herein shall remain vested in the Contractor or, if they are furnished to the Employer directly or through the Contractor by any third Party, including suppliers of materials, the copyright in such materials shall remain vested in such third Party. However, this

shall not prejudice the right of the Employer to use these drawings, documents and other materials containing data and information for Employer's own use whatsoever including future procurements basis the same.

## **16. Confidential Information**

- 16.1 The Employer and the Contractor shall keep confidential and shall not, without the written consent of the other Party hereto, divulge to any third Party any documents, data, drawings or other information furnished directly or indirectly by the other Party hereto in connection with the Contract, whether such information has been furnished prior to, during or following termination of the Contract. Notwithstanding the above, the Contractor may furnish to its SubContractor(s) such documents, data and other information it receives from the Employer to the extent required for the SubContractor(s) to perform its work under the Contract, in which event the Contractor shall obtain from such SubContractor(s) an undertaking of confidentiality similar to that imposed on the Contractor under this GCC Clause 16.
- 16.2 The Employer shall not use such documents, data and other information received from the Contractor for any purpose other than the operation and maintenance of the Facilities, including procurement of future spares. Similarly, the Contractor shall not use such documents, data and other information received from the Employer for any purpose other than the design, procurement of Plant, construction or such other work and services as are required for the performance of the Contract.
- 16.3 The obligation of a Party under GCC Sub-Clauses 16.1 and 16.2 above, however, shall not apply to that information which
- (a) now or hereafter enters the public domain through no fault of that Party
  - (b) can be proven to have been possessed by that Party at the time of disclosure and which was not previously obtained, directly or indirectly, from the other Party hereto

(c) otherwise lawfully becomes available to that Party from a third Party that has no obligation of confidentiality.

16.4 The above provisions of this GCC Clause 16 shall not in any way modify any undertaking of confidentiality given by either of the Parties hereto prior to the date of the Contract in respect of the Facilities or any part thereof.

16.5 The provisions of this GCC Clause 16 shall survive termination, for whatever reason, of the Contract.

## **E. Execution of the Facilities**

### **17. Representatives**

#### **17.1 Project Manager**

If the Project Manager is not named in the Contract, then within fourteen (14) days of the Effective Date, the Employer shall appoint and notify the Contractor in writing of the name of the Project Manager. The Employer may from time to time appoint some other person as the Project Manager in place of the person previously so appointed, and shall give a notice of the name of such other person to the Contractor without delay. No such appointment shall be made at such a time or in such a manner as to impede the progress of work on the Facilities. Such appointment shall only take effect upon receipt of such notice by the Contractor. The Project Manager shall represent and act for the Employer at all times during the performance of the Contract. All notices, instructions, orders, certificates, approvals and all other communications under the Contract shall be given by the Project Manager, except as herein otherwise provided.

#### **17.2 Contractor's Representative & Construction Manager**

17.2.1 If the Contractor's Representative is not named in the Contract, then within fourteen (14) days of the Effective Date, the Contractor shall appoint the Contractor's Representative and shall request the Employer in writing to approve the person so appointed. If the Employer makes no

objection to the appointment within fourteen (14) days, the Contractor's Representative shall be deemed to have been approved. If the Employer objects to the appointment within fourteen (14) days giving the reason therefor, then the Contractor shall appoint a replacement within fourteen (14) days of such objection, and the foregoing provisions of this GCC Sub-Clause 17.2.1 shall apply thereto.

17.2.2 The Contractor's Representative shall represent and act for the Contractor at all times during the performance of the Contract and shall give to the Project Manager all the Contractor's notices, instructions, information and all other communications under the Contract.

All notices, instructions, information and all other communications given by the Employer or the Project Manager to the Contractor under the Contract shall be given to the Contractor's Representative or, in its absence, its deputy, except as herein otherwise provided.

The Contractor shall not revoke the appointment of the Contractor's Representative without the Employer's prior written consent, which shall not be unreasonably withheld. If the Employer consents thereto, the Contractor shall appoint some other person as the Contractor's Representative, pursuant to the procedure set out in GCC Sub-Clause 17.2.1.

17.2.3 The Contractor's Representative may, subject to the approval of the Employer which shall not be unreasonably withheld, at any time delegate to any person any of the powers, functions and authorities vested in him or her. Any such delegation may be revoked at any time. Any such delegation or revocation shall be subject to a prior notice signed by the Contractor's Representative, and shall specify the powers, functions and authorities thereby delegated or revoked. No such delegation or revocation shall take effect unless and until a copy thereof has been delivered to the Employer and the Project Manager.

Any act or exercise by any person of powers, functions and authorities so delegated to him or her in accordance with this GCC Sub-Clause 17.2.3



shall be deemed to be an act or exercise by the Contractor's Representative.

17.2.4 From the commencement of installation of the Facilities at the Site until Completion, the Contractor's Representative shall appoint a suitable person as the Construction Manager. The Construction Manager shall supervise all work done at the Site by the Contractor and shall be present at the Site throughout normal working hours except when on leave, sick or absent for reasons connected with the proper performance of the Contract. Whenever the Construction Manager is absent from the Site, a suitable person shall be appointed to act as the Construction Manager's deputy.

17.2.5 The Employer may by notice to the Contractor object to any representative or person employed by the Contractor in the execution of the Contract who, in the reasonable opinion of the Employer, may behave inappropriately, may be incompetent or negligent, or may commit a serious breach of the Site regulations provided under GCC Sub-Clause 22.4. The Employer shall provide evidence of the same, whereupon the Contractor shall remove such person from the Facilities.

17.2.6 If any representative or person employed by the Contractor is removed in accordance with GCC Sub-Clause 17.2.5, the Contractor shall, where required, promptly appoint a replacement at his own cost.

## **18. Work Program**

### **18.1 Contractor's Organization**

The Contractor shall supply to the Employer and the Project Manager a chart showing the proposed organization to be established by the Contractor for carrying out work on the Facilities within twenty-one (21) days of the Effective Date. The chart shall include the identities of the key personnel and the curricula vitae of such key personnel to be employed shall be supplied together with the chart. The Contractor shall promptly inform the Employer and the Project Manager in writing of any revision or alteration of such an organization chart.

### **18.2 Program of Performance**

Within twenty-eight (28) days after the Effective Date, the Contractor shall submit to the Project

Manager a detailed program of performance of the Contract, made in a form acceptable to the Project Manager and showing the sequence in which it proposes to design, manufacture, transport, assemble, install and precommission the Facilities, as well as the date by which the Contractor reasonably requires that the Employer shall have fulfilled its obligations under the Contract so as to enable the Contractor to execute the Contract in accordance with the program and to achieve Completion including Commissioning and Acceptance of the Facilities in accordance with the Contract. The program so submitted by the Contractor shall accord with the Time Schedule included in the Appendix to the Contract Agreement titled Time Schedule, and any other dates and periods specified in the Contract. The Contractor shall update and revise the program as and when appropriate or when required by the Project Manager, but without modification in the Times for Completion specified in the SCC pursuant to Sub-Clause 8.2 and any extension granted in accordance with GCC Clause 40, and shall submit all such revisions to the Project Manager.

### 18.3 Progress Report

The Contractor shall monitor progress of all the activities specified in the program referred to in GCC Sub-Clause 18.2 above, and supply a progress report to the Project Manager every month.

The progress report shall be in a form acceptable to the Project Manager and shall indicate: (a) percentage completion achieved compared with the planned percentage completion for each activity; and (b) where any activity is behind the program, giving comments and likely consequences and stating the corrective action being taken.

### 18.4 Progress of Performance

If at any time the Contractor's actual progress falls behind the program referred to in GCC Sub-Clause 18.2, or it becomes apparent that it will so fall behind, the Contractor shall, at the request of the Employer or the Project Manager, prepare and submit to the Project Manager a revised program, taking into account the prevailing circumstances, and shall notify the Project Manager of the steps being taken to expedite progress so as to attain

Completion of the Facilities within the Time for Completion under GCC Sub-Clause 8.2, any extension thereof entitled under GCC Sub-Clause 40.1, or any extended period as may otherwise be agreed upon between the Employer and the Contractor.

#### 18.5 Procedures

The Contract shall be executed in accordance with the Contract Documents including the procedures given in the Forms and Procedures of the Employer's Requirements.

The Contractor may execute the Contract in accordance with its own standard project execution plans and procedures to the extent that they do not conflict with the provisions contained in the Contract.

### **19. Subcontracting**

- 19.1 The Appendix to the Contract Agreement titled List of Major Items of Plant and Installation Services and List of Approved SubContractors, specifies major items of supply or services and a list of approved SubContractors against each item, including manufacturers. Insofar as no SubContractors are listed against any such item, the Contractor shall prepare a list of SubContractors for such item for inclusion in such list. The Contractor may from time to time propose any addition to or deletion from any such list. The Contractor shall submit any such list or any modification thereto to the Employer for its approval in sufficient time so as not to impede the progress of work on the Facilities. Such approval by the Employer for any of the SubContractors shall not relieve the Contractor from any of its obligations, duties or responsibilities under the Contract.
- 19.2 The Contractor shall select and employ its SubContractors for such major items from those listed in the lists referred to in GCC Sub-Clause 19.1.
- 19.3 For items or parts of the Facilities not specified in the Appendix to the Contract Agreement titled List of Major Items of Plant and Installation Services and List of Approved SubContractors, except when otherwise required as per the provisions of the Contract or instructions in writing by the Project

Manager including the provisions if any specified in SCC, the Contractor may employ such SubContractors as it may select, at its discretion.

- 19.4 Each sub-contract shall include provisions which would entitle the Employer to require the sub-contract to be assigned to the Employer under GCC 19.5 (if and when applicable), or in event of termination by the Employer under GCC 42.2.
- 19.5 If a subContractor's obligations extend beyond the expiry date of the relevant Defects Liability Period and the Project Manager, prior to that date, instructs the Contractor to assign the benefits of such obligations to the Employer, then the Contractor shall do so.

## **20. Design and Engineering**

### 20.1 Specifications and Drawings

- 20.1.1 The contractor shall execute the basic and detailed design and the engineering work in compliance with the provisions of the contract, or where not so specified, in accordance with good engineering practice.

The Contractor shall be responsible for any discrepancies, errors or omissions in the specifications, drawings and other technical documents that it has prepared, whether such specifications, drawings and other documents have been approved by the Project Manager or not, provided that such discrepancies, errors or omissions are not because of inaccurate information furnished in writing to the Contractor by or on behalf of the Employer.

- 20.1.2 The Contractor shall be entitled to disclaim responsibility for any design, data, drawing, specification or other document, or any modification thereof provided or designated by or on behalf of the Employer, by giving a notice of such disclaimer to the Project Manager.

### 20.2 Codes and Standards

Wherever references are made in the Contract to codes and standards in accordance with which the Contract shall be executed, the edition or the revised version of such codes and standards current at the date twenty-eight (28) days prior to date of Bid submission shall apply unless otherwise specified. During Contract execution, any changes in such codes and standards shall be applied subject to

approval by the Employer and shall be treated in accordance with GCC Clause 39.

### 20.3 Approval/Review of Technical Documents by Project Manager

20.3.1 The Contractor shall prepare or cause its SubContractors to prepare, and furnish to the Project Manager the documents listed in the Appendix to the Contract Agreement titled List of Documents for Approval or Review, or elsewhere in the Contract, for its approval or review as specified and in accordance with the requirements of GCC Sub-Clause 18.2 (Program of Performance).

Any part of the Facilities covered by or related to the documents to be approved by the Project Manager shall be executed only after the Project Manager's approval thereof.

GCC Sub-Clauses 20.3.2 through 20.3.7 shall apply to those documents requiring the Project Manager's approval, but not to those furnished to the Project Manager for its review only.

20.3.2 Within fourteen (14) days after receipt by the Project Manager of any document requiring the Project Manager's approval in accordance with GCC Sub-Clause 20.3.1, the Project Manager shall either return one copy thereof to the Contractor with its approval endorsed thereon or shall notify the Contractor in writing of its disapproval thereof and the reasons therefor and the modifications that the Project Manager proposes.

20.3.3 The Project Manager shall not disapprove any document, except on the grounds that the document does not comply with the Contract or that it is contrary to good engineering practice.

20.3.4 If the Project Manager disapproves the document, the Contractor shall modify the document and resubmit it for the Project Manager's approval in accordance with GCC Sub-Clause 20.3.2. If the Project Manager approves the document subject to

modification(s), the Contractor shall make the required modification(s), whereupon the document shall be deemed to have been approved.

20.3.5 If any dispute or difference occurs between the Employer and the Contractor in connection with or arising out of the disapproval by the Project Manager of any document and/or any modification(s) thereto that cannot be settled between the Parties within a reasonable period, then such dispute or difference may be referred for dispute resolution in accordance with GCC 46 hereof. If such dispute or difference is referred for dispute resolution in accordance with GCC 46, the Project Manager shall give instructions as to whether and if so, how, performance of the Contract is to proceed. The Contractor shall proceed with the Contract in accordance with the Project Manager's instructions, provided that if the Contractor's view on the dispute has been upheld, then the Contractor shall be reimbursed by the Employer for any additional costs incurred by reason of such instructions and shall be relieved of such responsibility or liability in connection with the dispute and the execution of the instructions as may be decided under the applicable dispute resolution forum, and the Time for Completion shall be extended accordingly.

20.3.6 The Project Manager's approval, with or without modification of the document furnished by the Contractor, shall not relieve the Contractor of any responsibility or liability imposed upon it by any provisions of the Contract except to the extent that any subsequent failure results from modifications required by the Project Manager.

20.3.7 The Contractor shall not depart from any approved document unless the Contractor has first submitted to the Project Manager an amended document and obtained the Project Manager's approval thereof, pursuant to the provisions of this GCC Sub-Clause 20.3.

## **21. Procurement**

### 21.1 Plant

The Contractor shall procure and transport all Plant in an expeditious and orderly manner to the Site.

### 21.2 Employer-Supplied Plant

If the Appendix to the Contract Agreement titled Scope of Works and Supply by the Employer, provides that the Employer shall furnish any specific items to the Contractor, the following provisions shall apply:

21.2.1 The Employer shall, at its own risk and expense, transport each item to the place on or near the Site as agreed upon by the Parties and make such item available to the Contractor at the time specified in the program furnished by the Contractor, pursuant to GCC Sub-Clause 18.2, unless otherwise mutually agreed.

21.2.2 Upon receipt of such item, the Contractor shall inspect the same visually and notify the Project Manager of any detected shortage, defect or default. The Employer shall immediately remedy any shortage, defect or default, or the Contractor shall, if practicable and possible, at the request of the Employer, remedy such shortage, defect or default at the Employer's cost and expense. After inspection, such item shall fall under the care, custody and control of the Contractor. The provision of this GCC Sub-Clause 21.2.2 shall apply to any item supplied to remedy any such shortage or default or to substitute for any defective item, or shall apply to defective items that have been repaired.

21.2.3 The foregoing responsibilities of the Contractor and its obligations of care, custody and control shall not relieve the Employer of liability for any undetected shortage, defect or default, nor place the Contractor under any liability for any such shortage, defect or default whether under GCC Clause 27 or under any other provision of Contract.

### 21.3 Transportation

21.3.1 The Contractor shall at its own risk and expense transport all the materials and the Contractor's Equipment to the Site by the mode of transport that the Contractor judges most suitable under all the circumstances.

21.3.2 Unless otherwise provided in the Contract, the Contractor shall be entitled to select any safe mode of transport operated by any person to carry the materials and the Contractor's Equipment.

21.3.3 Upon dispatch of each shipment of materials and the Contractor's Equipment, the Contractor shall notify the Employer by telex, cable, facsimile or electronic means, of the description of the materials and of the Contractor's Equipment, the point and means of dispatch, and the estimated time and point of arrival at the Site. The Contractor shall furnish the Employer with relevant documents to be agreed upon between the Parties.

21.3.4 The Contractor shall be responsible for obtaining, if necessary, approvals from the authorities for transportation of the materials and the Contractor's Equipment to the Site. The Employer shall use its best endeavors in a timely and expeditious manner to assist the Contractor in obtaining such approvals, if requested by the Contractor. The Contractor shall indemnify and hold harmless the Employer from and against any claim for damage to roads, bridges or any other traffic facilities that may be caused by the transport of the materials and the Contractor's Equipment to the Site.

#### 21.4 Customs Clearance

The Contractor shall, at its own expense, handle and be responsible and liable for all imported materials and Contractor's Equipment including Customs clearance and shall handle any formalities for the same, provided that if applicable laws or regulations require any application or act to be made by or in the name of the Employer, the Employer if considered fit and appropriate, may take such steps to comply with such requirement as the Employer may consider



necessary, without bearing any responsibility or liability for the same.

## **22. Installation**

### **22.1 Setting Out/Supervision**

22.1.1 Bench Mark: The Contractor shall be responsible for the true and proper setting-out of the Facilities in relation to bench marks, reference marks and lines provided to it in writing by or on behalf of the Employer.

If, at any time during the progress of installation of the Facilities, any error shall appear in the position, level or alignment of the Facilities, the Contractor shall forthwith notify the Project Manager of such error and, at its own expense, immediately rectify such error to the reasonable satisfaction of the Project Manager. If such error is based on incorrect data provided in writing by or on behalf of the Employer, the expense of rectifying the same shall be borne by the Employer.

22.1.2 Contractor's Supervision: The Contractor shall give or provide all necessary superintendence during the installation of the Facilities, and the Construction Manager or its deputy shall be constantly on the Site to provide full-time superintendence of the installation. The Contractor shall provide and employ only technical personnel who are skilled and experienced in their respective callings and supervisory staff who are competent to adequately supervise the work at hand.

### **22.2 Labor:**

#### **22.2.1 Engagement of Staff and Labor**

Except as otherwise stated in the Specification, the Contractor shall make arrangements for the engagement of all staff and labor, local or otherwise, and for their payment, housing, feeding and transport.

The Contractor shall provide and employ on the Site in the installation of the Facilities such skilled, semi-skilled and unskilled labor as is necessary for the proper and timely

execution of the Contract. The Contractor is encouraged to use local labor that has the necessary skills.

The Contractor shall be responsible for obtaining all necessary permit(s) and/or permissions(s) from the appropriate authorities for the entry of all labor and personnel to be employed on the Site. The Employer will, if requested by the Contractor, use his best endeavors in a timely and expeditious manner to assist the Contractor in obtaining any local, state, national or government permission required for bringing in the Contractor's personnel.

The Contractor shall at its own expense provide the means of repatriation to all of its and its SubContractor's personnel employed on the Contract at the Site to the place where they were recruited or to their domicile. It shall also provide suitable temporary maintenance of all such persons from the cessation of their employment on the Contract to the date programmed for their departure. In the event that the Contractor defaults in providing such means of transportation and temporary maintenance, the Employer may provide the same to such personnel and recover the cost of doing so from the Contractor.

#### 22.2.2 Persons in the Service of Employer

The Contractor shall not recruit, or attempt to recruit, staff and labor from amongst the Employer's Personnel.

#### 22.2.3 Labor Laws

The Contractor shall comply with all the relevant labor Laws applicable to the Contractor's Personnel, including Laws relating to their employment, health, safety, welfare, immigration and emigration, and shall allow them all their legal rights.

The Contractor shall at all times during the progress of the Contract use its best endeavors to prevent any unlawful, riotous or disorderly conduct or behavior by or

amongst its employees and the labor of its Subcontractors

The Contractor shall, in all dealings with its labor and the labor of its SubContractors currently employed on or connected with the Contract, pay due regard to all recognized festivals, official holidays, religious or other customs and all local laws and regulations pertaining to the employment of labor.

#### 22.2.4 Rates of Wages and Conditions of Labor

The Contractor shall pay rates of wages, and observe conditions of labor, which are not lower than those established for the trade or industry where the work is carried out. If no established rates or conditions are applicable, the Contractor shall pay rates of wages and observe conditions which are not lower than the general level of wages and conditions observed locally by employers whose trade or industry is similar to that of the Contractor.

The Contractor shall inform the Contractor's Personnel about their liability to pay personal income taxes in the Country in respect of such of their salaries, wages and allowances as are chargeable under the Laws for the time being in force, and the Contractor shall perform such duties in regard to such deductions thereof as may be imposed on him by such Laws.

#### 22.2.5 Working Hours

Normally, work may not be carried out on the Site on locally recognized days of rest, or outside the normal working hours, unless:

- (a) otherwise stated in the Contract,
- (b) the Project Manager gives consent, or
- (c) the work is unavoidable, or necessary for the protection of life or property or for the safety of the Works, in which case the Contractor shall immediately advise the Project Manager.

If and when the Contractor considers it necessary to carry out work at night or on public holidays so as to meet the Time for Completion and requests the Project Manager's consent thereto, the Project Manager shall not unreasonably withhold such consent.

This Sub-Clause shall not apply to any work which is customarily carried out by rotary or double-shifts.

#### 22.2.6 Facilities for Staff and Labor

Except as otherwise stated in the Specification, the Contractor shall provide and maintain all necessary accommodation and welfare facilities for the Contractor's Personnel. The Contractor shall also provide facilities for the Employer's Personnel if and as stated in the Specification.

The Contractor shall not permit any of the Contractor's Personnel to maintain any temporary or permanent living quarters within the structures forming part of the Permanent Works.

#### 22.2.7 Health and Safety

The Contractor shall at all times take all reasonable precautions to maintain the health and safety of the Contractor's Personnel. In collaboration with local health authorities, the Contractor shall ensure that medical staff, first aid facilities, sick bay and other services are available at all times at the Site and at any accommodation for Contractor's and Employer's Personnel, and that suitable arrangements are made for all necessary welfare and hygiene requirements and for the prevention of epidemics.

The Contractor shall appoint an accident prevention officer at the Site, responsible for maintaining safety and protection against accidents. This person shall be qualified for this responsibility, and shall have the authority to issue instructions and take protective measures to prevent accidents. Throughout the performance of the Contract,

the Contractor shall provide whatever is required by this person to exercise this responsibility and authority.

The Contractor shall send to the Project Manager, details of any accident as soon as practicable after its occurrence. The Contractor shall maintain records and make reports concerning health, safety and welfare of persons, and damage to property, as the Project Manager may reasonably require.

The Contractor shall throughout the contract (including the Defects Notification Period): (i) conduct Information, Education and Consultation Communication (IEC) campaigns, as per guidelines of concerned local, state or government authorities, addressed to all the Site staff and labor (including all the Contractor's employees, all SubContractors, and all truck drivers and crew making deliveries to Site for construction activities) and to the immediate local communities, concerning the risks, dangers and impact, and appropriate avoidance behavior with respect to of risks of various transmittable diseases, epidemic etc.

#### 22.2.8 Funeral Arrangements

In the event of the death of any of the Contractor's personnel or accompanying members of their families, the Contractor shall be responsible for making the appropriate arrangements for their return or burial, unless otherwise specified in the **SCC**.

#### 22.2.9 Records of Contractor's Personnel

The Contractor shall keep accurate records of the Contractor's personnel, including the number of each class of Contractor's Personnel on the Site and the names, ages, genders, hours worked and wages paid to all workers. These records shall be available for inspection by the Project Manager until the Contractor has completed all work.

#### 22.2.10 Supply of Water

The Contractor shall, having regard to local conditions, provide on the Site an adequate supply of drinking .

#### 22.2.11 Prohibition of All Forms of Forced or Compulsory Labor

The Contractor shall not employ “forced or compulsory labor” in any form. “Forced or compulsory labor” consists of all work or service, not voluntarily performed, that is extracted from an individual under threat of force or penalty.

#### 22.2.12 Prohibition of Harmful Child Labor

The Contractor shall not employ any child to perform any work that is economically exploitative, or is likely to be hazardous to, or to interfere with, the child's education, or to be harmful to the child's health or physical, mental, spiritual, moral, or social development, as may be required as per the applicable laws.

### 22.3 Contractor's Equipment

22.3.1 All Contractor's Equipment brought by the Contractor onto the Site shall be deemed to be intended to be used exclusively for the execution of the Contract. The Contractor shall not remove the same from the Site without the Project Manager's consent that such Contractor's Equipment is no longer required for the execution of the Contract.

22.3.2 Unless otherwise specified in the Contract, upon completion of the Facilities, the Contractor shall remove from the Site all Equipment brought by the Contractor onto the Site and any surplus materials remaining thereon.

22.3.3 The Employer will, if requested, use its best endeavors to assist the Contractor in obtaining any local, state or national government permission required by the Contractor for removal of the equipment from Site, which was brought to Site by the Contractor for use in the execution of the

Contract that is no longer required for the execution of the Contract.

#### 22.4 Site Regulations and Safety

The Employer and the Contractor shall establish Site regulations setting out the rules to be observed in the execution of the Contract at the Site and shall comply therewith. The Contractor shall prepare and submit to the Employer, with a copy to the Project Manager, proposed Site regulations for the Employer's approval, which approval shall not be unreasonably withheld.

Such Site regulations shall include, but shall not be limited to, rules in respect of security, safety of the Facilities, gate control, sanitation, medical care, and fire prevention.

#### 22.5 Opportunities for Other Contractors

22.5.1 The Contractor shall, upon written request from the Employer or the Project Manager, give all reasonable opportunities for carrying out the work to any other Contractors employed by the Employer on or near the Site.

22.5.2 If the Contractor, upon written request from the Employer or the Project Manager, makes available to other Contractors any roads or ways the maintenance for which the Contractor is responsible, permits the use by such other Contractors of the Contractor's Equipment, or provides any other service of whatsoever nature for such other Contractors, the Employer shall fully compensate the Contractor for any loss or damage caused or occasioned by such other Contractors in respect of any such use or service, and shall pay to the Contractor reasonable remuneration for the use of such equipment or the provision of such services.

22.5.3 The Contractor shall also so arrange to perform its work as to minimize, to the extent possible, interference with the work of other Contractors. The Project Manager shall determine the resolution of any difference or conflict that may arise between the Contractor and other Contractors and the

workers of the Employer in regard to their work.

22.5.4 The Contractor shall notify the Project Manager promptly of any defects in the other Contractors' work that come to its notice, and that could affect the Contractor's work. The Project Manager shall determine the corrective measures, if any, required to rectify the situation after inspection of the Facilities. Decisions made by the Project Manager shall be binding on the Contractor.

## 22.6 Emergency Work

If, by reason of an emergency arising in connection with and during the execution of the Contract, any protective or remedial work is necessary as a matter of urgency to prevent damage to the Facilities, the Contractor shall immediately carry out such work.

If the Contractor is unable or unwilling to do such work immediately, the Employer may do or cause such work to be done as the Employer may determine is necessary in order to prevent damage to the Facilities. In such event the Employer shall, as soon as practicable after the occurrence of any such emergency, notify the Contractor in writing of such emergency, the work done and the reasons therefor. If the work done or caused to be done by the Employer is work that the Contractor was liable to do at its own expense under the Contract, the reasonable costs incurred by the Employer in connection therewith shall be paid by the Contractor to the Employer. Otherwise, the cost of such remedial work shall be borne by the Employer.

## 22.7 Site Clearance

22.7.1 Site Clearance in Course of Performance: In the course of carrying out the Contract, the Contractor shall keep the Site reasonably free from all unnecessary obstruction, store or remove any surplus materials, clear away any wreckage, rubbish or temporary works from the Site, and remove any Contractor's Equipment no longer required for execution of the Contract.

22.7.2 Clearance of Site after Completion: After Completion of all parts of the Facilities, the



Contractor shall clear away and remove all wreckage, rubbish and debris of any kind from the Site, and shall leave the Site and Facilities in a clean and safe condition.

#### 22.8 Watching and Lighting

The Contractor shall provide and maintain at its own expense allighting, fencing, and watching when and where necessary for the proper execution and the protection of the Facilities, or for the safety of the owners and occupiers of adjacent property and for the safety of the public.

### **23. Test and Inspection**

23.1 The Contractor shall at its own expense carry out at the place of manufacture and/or on the Site all such tests and/or inspections of the Plant and any part of the Facilities as are specified in the Contract.

23.2 The Employer and the Project Manager or their designated representatives shall be entitled to attend the aforesaid test and/or inspection, provided that the Employer shall bear all costs and expenses incurred in connection with such attendance including, but not limited to, all traveling and board and lodging expenses.

23.3 Whenever the Contractor is ready to carry out any such test and/or inspection, the Contractor shall give a reasonable advance notice of such test and/or inspection and of the place and time thereof to the Project Manager. The Contractor shall obtain from any relevant third Party or manufacturer any necessary permission or consent to enable the Employer and the Project Manager or their designated representatives to attend the test and/or inspection.

23.4 The Contractor shall provide the Project Manager with a certified report of the results of any such test and/or inspection.

If the Employer or Project Manager or their designated representatives fails to attend the test and/or inspection, or if it is agreed between the Parties that such persons shall not do so, then the Contractor may proceed with the test and/or inspection in the absence of such persons, and may provide the Project Manager with a certified report of the results thereof.

- 23.5 The Project Manager may require the Contractor to carry out any test and/or inspection not required by the Contract, provided that the Contractor's reasonable costs and expenses incurred in the carrying out of such test and/or inspection shall be added to the Contract Price. Further, if such test and/or inspection impede the progress of work on the Facilities and/or the Contractor's performance of its other obligations under the Contract, due allowance will be made in respect of the Time for Completion and the other obligations so affected.
- 23.6 If any Plant or any part of the Facilities fails to pass any test and/or inspection, the Contractor shall either rectify or replace such Plant or part of the Facilities and shall repeat the test and/or inspection upon giving a notice under GCC Sub-Clause 23.3.
- 23.7 If any dispute or difference of opinion shall arise between the Parties in connection with or arising out of the test and/or inspection of the Plant or part of the Facilities that cannot be settled between the Parties within a reasonable period of time, it may be referred for settlement of dispute in accordance with GCC Clause 46.
- 23.8 The Contractor shall afford the Employer and the Project Manager, at the Employer's expense, access at any reasonable time to any place where the Plant are being manufactured or the Facilities are being installed, in order to inspect the progress and the manner of manufacture or installation, provided that the Project Manager shall give the Contractor a reasonable prior notice.
- 23.9 The Contractor agrees that neither the execution of a test and/or inspection of Plant or any part of the Facilities, nor the attendance by the Employer or the Project Manager, nor the issue of any test certificate pursuant to GCC Sub-Clause 23.4, shall release the Contractor from any other responsibilities under the Contract.
- 23.10 No part of the Facilities or foundations shall be covered up on the Site without the Contractor carrying out any test and/or inspection required under the Contract. The Contractor shall give a reasonable notice to the Project Manager whenever any such parts of the Facilities or foundations are ready or about to be ready for test and/or inspection;

such test and/or inspection and notice thereof shall be subject to the requirements of the Contract.

- 23.11 The Contractor shall uncover any part of the Facilities or foundations, or shall make openings in or through the same as the Project Manager may from time to time require at the Site, and shall reinstate and make good such part or parts.

If any parts of the Facilities or foundations have been covered up at the Site after compliance with the requirement of GCC Sub-Clause 23.10 and are found to be executed in accordance with the Contract, the expenses of uncovering, making openings in or through, reinstating, and making good the same shall be borne by the Employer, and the Time for Completion shall be reasonably adjusted to the extent that the Contractor has thereby been delayed or impeded in the performance of any of its obligations under the Contract.

The Employer/Nodal agency/ Third part inspecting agency may also deploy mobile vans with Testing facility to test the plants and facilities by selecting random samples from store or from site. In such a case if the material/ facility fails, the same shall be replaced with new material, and one more random sample would be selected from the same batch for testing. If the material fails the test again, then the whole lot shall be replaced by the Contractor at its own risk and cost.

**24. Precommissioning,  
Commissioning,  
Guarantee Tests and  
Completion of the  
Facilities**

24.1 Pre- Commissioning

- 24.1.1 As soon as the Facilities or any part thereof have, in the opinion of the Contractor/Bidder, been completed operationally and structurally and put in a tight and clean condition as specified in the Employer's Requirements, excluding minor items not materially affecting the operation or safety of the Facilities, the Contractor/Bidder shall so notify the Employer in writing.

- 24.1.2 Within seven (7) days after receipt of the notice from the Contractor/Bidder under GCC Sub-Clause 24.1.1, the Employer shall supply the operating and maintenance personnel specified in the Appendix to the Contract Agreement titled Scope of Works and Supply by the Employer for

Precommissioning of the Facilities or any part thereof.

Pursuant to the Appendix to the Contract Agreement titled Scope of Works and Supply by the Employer, the Employer shall also provide, within the said seven (7) day period, the utilities, facilities, services and other matters required for Precommissioning of the Facilities or any part thereof.

- 24.1.3 As soon as reasonably practicable after the operating and maintenance personnel have been supplied by the Employer and the utilities, facilities, services and other matters have been provided by the Employer in accordance with GCC Sub-Clause 24.1.2, the Contractor shall commence Precommissioning of the Facilities or the relevant part thereof in preparation for Commissioning, subject to GCC Sub-Clause 24.8.
- 24.1.4 As soon as all works in respect of Precommissioning are completed and, in the opinion of the Contractor, the Facilities or any part thereof are ready for Commissioning, the Contractor/Bidder shall so notify the Project Manager in writing.
- 24.1.5 The Project Manager, within fourteen (14) days after receipt of the Contractor's notice under GCC Sub-Clause 24.1.4, either intimate in writing to commence Commissioning, or notify the defects and/or deficiencies to be rectified/ corrected by the Contractor pending which Commissioning cannot be commenced.
- 24.1.6 If the Project Manager notifies the Contractor of any defects and/or deficiencies, the Contractor shall then correct/ rectify such defects and/or deficiencies, and shall repeat the procedure described in GCC Sub-Clause 24.1.4.
- 24.1.7 If the Project Manager is satisfied that the Facilities or that part thereof are ready for Commissioning, the Project Manager shall, within seven (7) days after receipt of the Contractor's repeated notice, issue a communication in writing to the Contractor to commence Commissioning.

If the Project Manager is not so satisfied, then it shall notify the Contractor in writing of any defects and/or deficiencies within seven (7) days after receipt of the Contractor's repeated notice, and the above procedure shall be repeated.

24.1.8 If the Project Manager fails to issue any written communication/ intimation to the Contractor, and fails to inform the Contractor of any defects and/or deficiencies within fourteen (14) days after receipt of the Contractor's notice under GCC Sub-Clause 24.4.1 or within seven (7) days after receipt of the Contractor's repeated notice, then the Facilities or that part thereof shall be deemed to be ready for Commissioning as on expiry of the 14 days/ 7 days period as aforesaid, as the case may be.

## 24.2 Commissioning

24.2.1 Commissioning of the Facilities or any part thereof shall be commenced by the Contractor immediately after issue of the written intimation for the same by the Project Manager.

24.2.2 The Employer shall supply the operating and maintenance personnel and all utilities, facilities, services and other matters required for Commissioning.

24.2.3 In accordance with the requirements of the Contract, the Contractor's and Project Manager's advisory personnel shall attend the Commissioning, including the Guarantee Test, and shall advise and assist the Employer.

## 24.3 Guarantee Test

24.3.1 Subject to GCC Sub-Clause 24.8, the Guarantee Test and repeats thereof shall be conducted by the Contractor during Commissioning of the Facilities or the relevant part thereof to ascertain whether the Facilities or the relevant part can attain the Functional Guarantees specified in the Appendix to the Contract Agreement titled Functional Guarantees. The Employer shall promptly provide the Contractor with such information as the Contractor may reasonably require in relation to the conduct and results of the Guarantee Test and any repeats thereof.

## 24.4 Completion

24.4.1As soon as all works in respect of Precommissioning, Commissioning, Guarantee Tests and geo-tagging of the assets on GIS portal, are completed in the opinion of the Contractor, the Facilities or any part thereof have achieved Completion, the Contractor shall so notify the Project Manager in writing.

24.4.2 The Project Manager shall, within fourteen (14) days after receipt of the Contractor's notice under GCC Sub-Clause 24.4.1, either issue a Completion Certificate in the form specified in the Section 8, stating that the Facilities or that part thereof have reached Completion as of the date of the Contractor's notice under GCC Sub-Clause 24.4.1, or notify the Contractor in writing of any defects and/or deficiencies.

24.4.3 If the Project Manager notifies the Contractor of any defects and/or deficiencies, the Contractor shall then correct such defects and/or deficiencies, and shall repeat the procedure described in GCC Sub-Clause 24.4.1.

24.4.4 If the Project Manager is satisfied that the Facilities or that part thereof have reached Completion, the Project Manager shall, within seven (7) days after receipt of the Contractor's repeated notice, issue a Completion Certificate stating that the Facilities or that part thereof have reached Completion as of the date of the Contractor's repeated notice.

If the Project Manager is not so satisfied, then it shall notify the Contractor in writing of any defects and/or deficiencies within seven (7) days after receipt of the Contractor's repeated notice, and the above procedure shall be repeated.

24.4.5 If the Project Manager fails to issue the Completion Certificate and fails to inform the Contractor of any defects and/or deficiencies within fourteen (14) days after receipt of the Contractor's notice under GCC Sub-Clause 24.4.1 or within seven (7) days after receipt of the Contractor's repeated notice under GCC Sub-Clause 24.4.4, or if the Employer makes use of

the Facilities or part thereof, then the Facilities or that part thereof shall be deemed to have reached Completion as of the date of the Contractor's notice or repeated notice, or as of the Employer's use of the Facilities, as the case may be. The Contractor shall accordingly issue written communication/ intimation on the same to the Project Manager.

24.5 As soon as possible after Completion, the Contractor shall complete all outstanding minor items so that the Facilities are fully in accordance with the requirements of the Contract, failing which the Employer will undertake such completion and deduct the costs thereof from any monies owing to the Contractor.

24.6 Upon Completion, the Employer shall be responsible for the care and custody of the Facilities or the relevant part thereof, together with the risk of loss or damage thereto, and shall thereafter take over the Facilities or the relevant part thereof.

#### 24.7 Partial Acceptance

24.7.1 If the Contract specifies that Commissioning and Completion shall be carried out in respect of parts of the Facilities, the provisions relating to Commissioning and Completion including the Guarantee Test shall apply to each such part of the Facilities individually, and the Completion Certificate shall be issued accordingly for each such part of the Facilities.

#### 24.8 Delayed Precommissioning, Commissioning and/or Guarantee Test

24.8.1 In the event that the Contractor is unable to proceed with the Precommissioning of the Facilities pursuant to GCC Sub-Clause 24.1, or with the Commissioning/Guarantee Test pursuant to GCC Sub-Clause 24.2/ 24.3, for reasons attributable to the Employer either on account of non availability of other facilities under the responsibilities of other Contractor(s), or for reasons beyond the Contractor's control, the provisions leading

to “deemed” completion of activities such as Completion, pursuant to GCC Sub-Clause 24.4, and Operational Acceptance, pursuant to GCC Sub-Clause 25, and Contractor’s obligations regarding Defect Liability Period, pursuant to GCC Sub-Clause 27.2, Functional Guarantee, pursuant to GCC Clause 28, and Care of Facilities, pursuant to GCC Clause 32, and GCC Clause 41.1, Suspension, shall not apply. In this case, the following provisions shall apply.

24.8.2 When the Contractor is notified by the Project Manager that he will be unable to proceed with the activities and obligations pursuant to above Sub-Clause 24.8.1, the Contractor shall be entitled to the following:

- (a) the Time of Completion shall be extended for the period of suspension without imposition of liquidated damages pursuant to GCC Sub-Clause 26.2;
- (b) payments due to the Contractor in accordance with the provision specified in the Appendix to the Contract Agreement titled Terms and Procedures of Payment, which would not have been payable in normal circumstances due to non-completion of the subject activities, shall be released to the Contractor against submission of a security in the form of a bank guarantee of equivalent amount acceptable to the Employer, and which shall become null and void when the Contractor will have complied with its obligations regarding those payments, subject to the provision of Sub-Clause 24.8.3 below;
- (c) the expenses towards the above security and extension of other securities under the contract, of which validity needs to be extended, shall be reimbursed to the Contractor by the Employer;
- (d) the additional charges towards the care of the Facilities pursuant to GCC Sub-



Clause 32.1 shall be reimbursed to the Contractor by the Employer for the period between the notification mentioned above and the notification mentioned in Sub-Clause 24.8.4 below. The provision of GCC Sub-Clause 33.2 shall apply to the Facilities during the same period.

24.8.3 In the event that the period of suspension under above Sub-Clause 24.8.1 actually exceeds one hundred eighty (180) days, the Employer and Contractor shall mutually agree to any additional compensation payable to the Contractor.

24.8.4 When the Contractor is notified by the Project Manager that the plant is ready for Precommissioning/ Commissioning/ Guarantee Tests, the Contractor shall proceed without delay in performing Precommissioning, Commissioning, Guarantee Tests and achieving Completion in accordance with GCC Clause 24.

## **25. Operational Acceptance**

### **25.1 Operational Acceptance**

25.1.1 Subject to GCC Sub-Clause 24.7, Operational Acceptance shall occur in respect of the Facilities or any part thereof when

- (a) the Guarantee Test has been successfully completed and the Functional Guarantees are met; or
- (b) the Contractor has paid the liquidated damages specified in GCC Sub-Clause 28.3 hereof; and
- (c) any minor items mentioned in GCC Sub-Clause 24.5 hereof relevant to the Facilities or that part thereof have been completed.

25.1.2 In case if the requirements of GCC 25.1.1 have been complied upon or before achieving the Completion, Operational Acceptance shall be deemed to have occurred upon Completion. In case if the requirements of GCC 25.1.1 have been not been complied upon on or before achieving the Completion, at any time after the same are complied, the Contractor may give a notice to the

Project Manager requesting the issue of an Operational Acceptance Certificate in respect of the Facilities or the part thereof specified in such notice as of the date of such notice.

25.3.3 The Project Manager shall, after consultation with the Employer, and within seven (7) days after receipt of the Contractor's notice, issue an Operational Acceptance Certificate.

25.3.4 If within seven (7) days after receipt of the Contractor's notice, the Project Manager fails to issue the Operational Acceptance Certificate or fails to inform the Contractor in writing of the justifiable reasons why the Project Manager has not issued the Operational Acceptance Certificate, the Facilities or the relevant part thereof shall be deemed to have been accepted as of the date of the Contractor's said notice. The Contract shall intimate the same to the Project Manager through awritten communication/ intimation.

## **F. Guarantees and Liabilities**

### **26. Completion Time Guarantee**

26.1 The Contractor guarantees that it shall attain Completion of the Facilities (or a part for which a separate time for completion is specified) within the Time for Completion specified in the **SCC** pursuant to GCC Sub-Clause 8.2, or within such extended time to which the Contractor shall be entitled under GCC Clause 40 hereof.

26.2 If the Contractor fails to attain Completion of the Facilities or any part thereof within the Time for Completion or any extension thereof under GCC Clause 40, the Contractor shall pay to the Employer liquidated damages in the amount specified in the **SCC** as a percentage rate of the Contract Price or the relevant part thereof. The aggregate amount of such liquidated damages shall in no event exceed the amount specified as "Maximum" in the **SCC** as a percentage rate of the Contract Price. Once the "Maximum" is reached, the Employer may consider termination of the Contract, pursuant to GCC Sub-Clause 42.2.2.

Such payment shall completely satisfy the Contractor's obligation to attain Completion of the Facilities or the relevant part thereof within the Time for Completion or any extension thereof under GCC Clause 40. The Contractor shall have no further liability whatsoever to the Employer in respect thereof.

However, the payment of liquidated damages shall not in any way relieve the Contractor from any of its obligations to complete the Facilities or from any other obligations and liabilities of the Contractor under the Contract.

Save for liquidated damages payable under this GCC Sub-Clause 26.2, the failure by the Contractor to attain any milestone or other act, matter or thing by any date specified in the Appendix to the Contract Agreement titled Time Schedule, and/or other program of work prepared pursuant to GCC Sub-Clause 18.2 shall not render the Contractor liable for any loss or damage thereby suffered by the Employer.

## **27. Defect Liability**

27.1 The Contractor warrants that the Facilities or any part thereof shall be free from defects in the design, engineering, materials and workmanship of the Plant supplied and of the work executed. Further, in addition to the provisions contained herein, the provisions, if any, specified in **SCC** shall also apply.

27.2 The Defect Liability Period shall be Twelve (12) month from the date of Completion of the Facilities (or any part thereof) unless specified otherwise in the **SCC** pursuant to GCC Sub-Clause 27.10, and the duration of every extension applicable (as per GCC 27.8) should be same as the duration of the defect liability period above. The aggregate value of all extensions will be subject to the maximum extension permissible (as per GCC 27.8).

If during the Defect Liability Period any defect should be found in the design, engineering, materials and workmanship of the Plant supplied or of the Installation Services/ work executed by the Contractor, the Contractor shall promptly, in consultation and agreement with the Employer

regarding appropriate remedying of the defects, and at its own cost, repair, replace or otherwise make good such defect as well as any damage to the Facilities caused by such defect, to the satisfaction of the Employer. The Contractor shall not be responsible for the repair, replacement or making good of any defect or of any damage to the Facilities arising out of or resulting from any of the following causes:

- (a) improper operation or maintenance of the Facilities by the Employer;
- (b) operation of the Facilities outside specifications provided in the Contract; or
- (c) normal wear and tear.

27.3 The Contractor's obligations under this GCC Clause 27 shall not apply to:

- (a) any materials that are supplied by the Employer under GCC Sub-Clause 21.2, are normally consumed in operation, or have a normal life shorter than the Defect Liability Period stated herein;
- (b) any designs, specifications or other data designed, supplied or specified by or on behalf of the Employer or any matters for which the Contractor has disclaimed responsibility herein; or
- (c) any other materials supplied or any other work executed by or on behalf of the Employer, except for the work executed by the Employer under GCC Sub-Clause 27.7.

27.4 The Employer shall give the Contractor a notice stating the nature of any such defect together with all available evidence thereof, promptly following the discovery thereof. The Employer shall afford all reasonable opportunity for the Contractor to inspect any such defect.

27.5 The Employer shall afford the Contractor all necessary access to the Facilities and the Site to enable the Contractor to perform its obligations under this GCC Clause 27.

The Contractor may, with the consent of the Employer, remove from the Site any Plant or any part of the Facilities that are defective if the nature of the defect, and/or any damage to the Facilities caused by the defect, is such that repairs cannot be expeditiously carried out at the Site.

- 27.6 If the repair, replacement or making good is of such a character that it may affect the efficiency of the Facilities or any part thereof, the Employer may give to the Contractor a notice requiring that tests of the defective part of the Facilities shall be made by the Contractor immediately upon completion of such remedial work, whereupon the Contractor shall carry out such tests.

If such part fails the tests, the Contractor shall carry out further repair, replacement or making good, as the case may be, until that part of the Facilities passes such tests. The tests shall be agreed upon by the Employer and the Contractor.

- 27.7 If the Contractor fails to commence the work necessary to remedy such defect or any damage to the Facilities caused by such defect within a reasonable time (which shall in no event be considered to be less than fifteen (15) days), the Employer may, following notice to the Contractor, proceed to do such work, and the reasonable costs incurred by the Employer in connection therewith shall be paid to the Employer by the Contractor or may be deducted by the Employer from any monies due the Contractor or claimed under the Performance Security.

- 27.8 If the Facilities or any part thereof cannot be used by reason of such defect and/or making good of such defect, the Defect Liability Period of the Facilities or such part, as the case may be, shall be extended by a period equal to the period during which the Facilities or such part cannot be used by the Employer because of any of the aforesaid reasons.

Upon correction of the defects in the Facilities or any part thereof by repair/replacement, the repaired/replaced item(s) shall have the Defect Liability Period extended by a period mentioned in GCC Sub-Clause 27.2 from the time of such replacement/repair of the facilities or any part thereof. However, such extension

of Defect Liability Period, in aggregate, shall, not exceed the period specified in SCC.

27.8.1 At the end of the Defect Liability Period, the Contractor's Liability ceases except for latent defects. The Contractor's liability for latent defects warranty shall be limited to period specified in SCC, reckoned from the end of Defect Liability Period including extension thereof. For the purpose of this clause, the latent defects shall be the defects inherently lying within the material or arising out of design deficiency, which do not manifest themselves during the Defect Liability Period defined in this GCC Clause 27, but later. **The bidder should submit an undertaking in non-judicial stamp paper (Rs.100/-) for providing Latent Defect Coverage support warranty against each equipments and it shall be limited to period specified in SCC/Technical Specifications, reckoned from the end of defect liability period including extension thereof and the related format is enclosed herewith as Form-21.**

27.9 Except as provided in GCC Clauses 27 and 33, the Contractor shall be under no liability whatsoever and howsoever arising, and whether under the Contract or at law, in respect of defects in the Facilities or any part thereof, the Plant, design or engineering or work executed that appear after Completion of the Facilities or any part thereof, except where such defects are the result of the gross negligence, fraud, or criminal or willful action of the Contractor.

27.10 In addition, any such component of the Facilities, and during the period of time as may be specified in the SCC, shall be subject to an extended defect liability period. Such obligation of the Contractor shall be in addition to the defect liability period specified under GCC Sub-Clause 27.2.

## 28. Functional Guarantees

28.1 The Contractor guarantees that during the Guarantee Test, the Facilities and all parts thereof shall attain the Functional Guarantees specified in the Appendix to the Contract Agreement titled Functional Guarantees, subject to and upon the conditions therein specified.

28.2 If, for reasons attributable to the Contractor, the minimum level of the Functional Guarantees specified in the Appendix to the Contract Agreement titled Functional Guarantees, are not met either in

whole or in part, the Contractor shall at its cost and expense make such changes, modifications and/or additions to the Plant or any part thereof as may be necessary to meet at least the minimum level of such Guarantees. The Contractor shall notify the Employer upon completion of the necessary changes, modifications and/or additions, and shall request the Employer to repeat the Guarantee Test until the minimum level of the Guarantees has been met. If the Contractor eventually fails to meet the minimum level of Functional Guarantees, the Employer may consider termination of the Contract, pursuant to GCC Sub-Clause 42.2.2 subject to all other actions as deemed fit by the Employer including but not limited to legal recourse

28.3 If, for reasons attributable to the Contractor, the Functional Guarantees specified in the Appendix to the Contract Agreement titled Functional Guarantees, are not attained either in whole or in part, but the minimum level of the Functional Guarantees specified in the said Appendix to the Contract Agreement is met, the Contractor shall, at the Contractor's option, either

- (a) make such changes, modifications and/or additions to the Facilities or any part thereof that are necessary to attain the Functional Guarantees at its cost and expense, and shall request the Employer to repeat the Guarantee Test or
- (b) pay liquidated damages to the Employer in respect of the failure to meet the Functional Guarantees in accordance with the provisions in the Appendix to the Contract Agreement titled Functional Guarantees.

28.4 The payment of liquidated damages under GCC Sub-Clause 28.3, up to the limitation of liability specified in the Appendix to the Contract Agreement titled Functional Guarantees, shall completely satisfy the Contractor's guarantees under GCC Sub-Clause 28.3, and the Contractor shall have no further liability whatsoever to the Employer in respect thereof. Upon the payment of such liquidated damages by the Contractor, the Project Manager shall issue the Operational Acceptance Certificate for the Facilities or any part

thereof in respect of which the liquidated damages have been so paid.

## **29. Patent Indemnity**

- 29.1 The Contractor shall, subject to the Employer's compliance with GCC Sub-Clause 29.2, indemnify and hold harmless the Employer and its employees and officers from and against any and all suits, actions or administrative proceedings, claims, demands, losses, damages, costs, and expenses of whatsoever nature, including attorney's fees and expenses, which the Employer may suffer as a result of any infringement or alleged infringement of any patent, utility model, registered design, trademark, copyright or other intellectual property right registered or otherwise existing at the date of the Contract by reason of: (a) the installation of the Facilities by the Contractor or the use of the Facilities in the country where the Site is located; and (b) the sale of the products produced by the Facilities in any country.

Such indemnity shall not cover any use of the Facilities or any part thereof other than for the purpose indicated by or to be reasonably inferred from the Contract, any infringement resulting from the use of the Facilities or any part thereof, or any products produced thereby in association or combination with any other equipment, plant or materials not supplied by the Contractor, pursuant to the Contract Agreement.

- 29.2 If any proceedings are brought or any claim is made against the Employer arising out of the matters referred to in GCC Sub-Clause 29.1, the Employer shall promptly give the Contractor a notice thereof, and the Contractor may at its own expense and in the Employer's name conduct such proceedings or claim and any negotiations for the settlement of any such proceedings or claim.

If the Contractor fails to notify the Employer within twenty-eight (28) days after receipt of such notice that it intends to conduct any such proceedings or claim, then the Employer shall be free to conduct the same on its own behalf. Unless the Contractor has so failed to notify the Employer within the twenty-eight (28) day period, the Employer shall make no admission that may be prejudicial to the defense of any such proceedings or claim.



The Employer shall, at the Contractor's request, afford all available assistance to the Contractor in conducting such proceedings or claim, and shall be reimbursed by the Contractor for all reasonable expenses incurred in so doing.

29.3 The Employer shall indemnify and hold harmless the Contractor and its employees, officers and SubContractors from and against any and all suits, actions or administrative proceedings, claims, demands, losses, damages, costs, and expenses of whatsoever nature, including attorney's fees and expenses, which the Contractor may suffer as a result of any infringement or alleged infringement of any patent, utility model, registered design, trademark, copyright or other intellectual property right registered or otherwise existing at the date of the Contract arising out of or in connection with any design, data, drawing, specification, or other documents or materials provided or designed by or on behalf of the Employer.

### **30. Limitation of Liability**

30.1 Except in cases of criminal negligence or willful misconduct,

- (a) neither Party shall be liable to the other Party, whether in contract, tort, or otherwise, for any indirect or consequential loss or damage, loss of use, loss of production, or loss of profits or interest costs, which may be suffered by the other Party in connection with the Contract, other than specifically provided as any obligation of the Party in the Contract, and
- (b) the aggregate liability of the Contractor to the Employer, whether under the Contract, in tort or otherwise, shall not exceed the amount resulting from the application of the multiplier specified in the SCC, to the Contract Price or, if a multiplier is not so specified, the total Contract Price including any price adjustment pursuant to the Contract, provided that this limitation shall not apply to the cost of repairing or replacing defective equipment, or to any obligation of the Contractor to indemnify the Employer with respect to patent infringement.

## G. Risk Distribution

- 31. Transfer of Ownership**
- 31.1 Ownership of the Plant (including spare parts) shall be transferred to the Employer when the Plant are brought on to the Site.
- 31.2 Ownership of the Contractor's Equipment used by the Contractor and its SubContractors in connection with the Contract shall remain with the Contractor or its SubContractors.
- 31.3 Ownership of any Plant in excess of the requirements for the Facilities shall revert to the Contractor upon Completion of the Facilities or at such earlier time when the Employer and the Contractor agree that the Plant in question are no longer required for the Facilities.
- 31.5 Notwithstanding the transfer of ownership of the Plant, the responsibility for care and custody thereof together with the risk of loss or damage thereto shall remain with the Contractor pursuant to GCC Clause 32 (Care of Facilities) hereof until Completion of the Facilities or the part thereof in which such Plant are incorporated.
- 31.6 For the Plant/ goods/ equipment/material to be supplied by the Contractor under the Contract, it will be the responsibility of the Contractor to take delivery, unload and store the materials at Site and execute an Indemnity Bond and obtain authorisation letter from Employer as per specified proforma, in favour of the Employer against loss, damage and any risks involved for the full value of the Plant/ goods/ equipment/material. This Indemnity Bond, as provided in Section-8, shall be furnished by the Contractor before commencement of the supplies and shall be valid till the Completion of the Facilities.
- 31.7 Under the Contract, where the Employer hands over Employer supplied plant/ goods/ equipment/material to the Contractor for executing the Contract, then the Contractor shall, at the time of taking delivery of the equipment through Bill of Lading or other despatch documents, furnish trust Receipt for such plant/ goods/ equipment/material and also execute an Indemnity Bond, as provided in Section-8, in favour of the Employer in the form acceptable to the Employer for keeping the plant/ goods/ equipment/material in safe custody and to utilize the

same exclusively for the purpose of the Contract as per the specified proforma for the Trust receipt and Indemnity Bond. The Employer shall also issue a separate Authorization Letter to the Contractor to enable him to take physical delivery of plant/ goods/ equipment/material from the Employer as per specified proforma.

### **32. Care of Facilities**

32.1 The Contractor shall be responsible for the care and custody of the Facilities or any part thereof until the date of Completion of the Facilities pursuant to GCC Clause 24 or, where the Contract provides for Completion of the Facilities in parts, until the date of Completion of the relevant part, and shall make good at its own cost any loss or damage that may occur to the Facilities or the relevant part thereof from any cause whatsoever during such period. The Contractor shall also be responsible for any loss or damage to the Facilities caused by the Contractor or its SubContractors in the course of any work carried out, pursuant to GCC Clause 27. Notwithstanding the foregoing, the Contractor shall not be liable for any loss or damage to the Facilities or that part thereof caused by reason of any of the matters specified or referred to in paragraphs (a), (b) and (c) of GCC Sub-Clauses 32.2 and 38.1.

32.2 If any loss or damage occurs to the Facilities or any part thereof by reason of

- (a) insofar as they, in relation to Site, relate to nuclear reaction, nuclear radiation, radioactive contamination, pressure wave caused by aircraft or other aerial objects, or any other occurrences that an experienced Contractor could not reasonably foresee, or if reasonably foreseeable could not reasonably make provision for or insure against, insofar as such risks are not normally insurable on the insurance market and are in the general excluded of the policy of insurance, including War Risks and Political Risks, taken out under GCC Clause 34 hereof; or
- (b) any use or occupation by the Employer or any third Party other than a SubContractor, authorized by the Employer of any part of the Facilities; or
- (c) any use of or reliance upon any design, data or specification provided or designated by or on

behalf of the Employer, or any such matter for which the Contractor has disclaimed responsibility herein,

the Employer shall pay to the Contractor all sums payable in respect of the Facilities executed, notwithstanding that the same be lost, destroyed or damaged. If the Employer requests the Contractor in writing to make good any loss or damage to the Facilities thereby occasioned, the Contractor shall make good the same at the cost of the Employer in accordance with GCC Clause 39. If the Employer does not request the Contractor in writing to make good any loss or damage to the Facilities thereby occasioned, the Employer shall either request a change in accordance with GCC Clause 39, excluding the performance of that part of the Facilities thereby lost, destroyed or damaged, or, where the loss or damage affects a substantial part of the Facilities, the Employer shall terminate the Contract pursuant to GCC Sub-Clause 42.1 hereof.

32.3 The Contractor shall be liable for any loss of or damage to any Contractor's Equipment, or any other property of the Contractor used or intended to be used for purposes of the Facilities.

32.4 With respect to any loss or damage caused to the Facilities or any part thereof by reason of any of the matters specified in GCC Sub-Clause 38.1, the provisions of GCC Sub-Clause 38.3 shall apply.

**33. Loss of or Damage to Property; Accident or Injury to Workers; Indemnification**

33.1 Subject to GCC Sub-Clause 33.3, the Contractor shall indemnify and hold harmless the Employer and its employees and officers from and against any and all suits, actions or administrative proceedings, claims, demands, losses, damages, costs, and expenses of whatsoever nature, including attorney's fees and expenses, in respect of the death or injury of any person or loss of or damage to any property other than the Facilities whether accepted or not, arising in connection with the supply and installation of the Facilities and by reason of the negligence of the Contractor or its SubContractors, or their employees, officers or agents, except any injury, death or property damage caused by the negligence of the Employer, its Contractors, employees, officers or agents.

33.2 If any proceedings are brought or any claim is made against the Employer that might subject the Contractor to liability under GCC Sub-Clause 33.1, the Employer shall promptly give the Contractor a notice thereof and the Contractor may at its own expense and in the Employer's name conduct such proceedings or claim and any negotiations for the settlement of any such proceedings or claim.

If the Contractor fails to notify the Employer within twenty-eight (28) days after receipt of such notice that it intends to conduct any such proceedings or claim, then the Employer shall be free to conduct the same on its own behalf. Unless the Contractor has so failed to notify the Employer within the twenty-eight (28) day period, the Employer shall make no admission that may be prejudicial to the defense of any such proceedings or claim.

33.3 The Employer shall indemnify and hold harmless the Contractor and its employees, officers and SubContractors from any liability for loss of or damage to property of the Employer, other than the Facilities not yet taken over, that is caused by fire, explosion or any other perils, in excess of the amount recoverable from insurances procured under GCC Clause 34, provided that such fire, explosion or other perils were not caused by any act or failure of the Contractor.

33.4 The Party entitled to the benefit of an indemnity under this GCC Clause 33 shall take all reasonable measures to mitigate any loss or damage which has occurred. If the Party fails to take such measures, the other Party's liabilities shall be correspondingly reduced.

## **34. Insurance**

34.1 To the extent specified in the Appendix to the Contract Agreement titled Insurance Requirements, the Contractor shall at its expense take out and maintain in effect, or cause to be taken out and maintained in effect, during the performance of the Contract, the insurances set forth below in the sums and with the deductibles and other conditions specified in the said Appendix. The identity of the insurers and the form of the policies shall be subject to the approval of the Employer, who should not unreasonably withhold such approval.

a) Marine Cargo Policy/Transit Insurance Policy:

- I. (i) Marine Cargo policy for imported equipment  
Since imported finished materials are not permitted under the contract, this policy shall not be applicable,  
(ii) Transit Insurance Policy for indigenous equipment  
Transit Insurance Policy shall be taken wherein only inland transit is involved for the movement of Plant and Equipment supplied from within India. The policy shall cover movement of Plant and Equipment from the manufacturer's works to the project's warehouse at final destination site. Inland Transit Clause (ITC) 'A' along with war & Strike Riots & Civil Commotion (SRCC) extension cover shall be taken. The policy shall cover movement of Plant and Equipment from the manufacturer's works to the project's warehouse at final destination site. The policy shall cover all risk for loss or damage that may occur during transit of Plant and Equipment from the Contractor/sub-Contractor's works or stores until arrival at project's warehouse/ store at final destination. Institute Cargo Clause (ICC) 'A' along with war & Strike Riots & Civil Commotion (SRCC) cover shall be taken.
  - II. If during the execution of Contract, the Employer requests the Contractor to take any other add-on cover(s)/ supplementary cover(s) in aforesaid insurance, in such a case, the Contractor shall promptly take such add-on cover(s)/ supplementary cover(s) and the charges towards such premium for such add-on cover(s)/ supplementary cover(s) shall be reimbursed to the Contractor on submission documentary evidence of payment to the Insurance company. Therefore, charges towards premium for such add-on cover(s)/ supplementary cover(s) are not included in the Contract Price.
  - III. The Contractor shall take the policy in the joint names of Employer and the Contractor. The policy shall indicate the Employer as the beneficiary. However, if the Contractor is having an open policy for its line of business, it should obtain an endorsement of the open cover policy from the insurance company indicating that the dispatches against this Contract are duly covered under its open policy and include the name of the Employer as jointly Insured in the endorsements to the open policy.
- b) Erection All Risk Policy/Contractor All Risk Policy:

- I. The policy should cover all physical loss or damage to the facility at site during storage, erection and commissioning covering all the perils as provided in the policy as a basic cover and the add on covers as mentioned at Sl. No. (III) below.
- II. The Contractor shall take the policy in the joint name of Employer and the Contractor. All these policies shall indicate Employer as the beneficiary. The policy shall be kept valid till the date of the Operational Acceptance of the project and the period of the coverage shall be determined with the approval of the Employer.

If the work is completed earlier than the period of policy considered, the Contractor shall obtain the refund as per provisions of the policy and pass on the benefit to Employer. In case no refund is payable by the insurance company then the certificate to that effect shall be submitted to Employer at the completion of the project.

- III. The following add-on covers shall also be taken by the Contractor:
  - i. Earthquake
  - ii. Terrorism
  - iii. Escalation cost (approximately @10% of sum insured on annual basis)
  - iv. Extended Maintenance cover for Defect Liability Period
  - v. Design Defect
  - vi. Other add-on covers viz., 50-50 clause, 72 hours clause, loss minimization clause, waiver of subrogation clause (for projects of more than Rs. 100 crores, cover for offsite storage/fabrication (over Rs. 100 crores).
- IV. Third Party Liability cover with cross Liability within Geographical limits of India as on ADD-on cover to the basic EAR cover:

The third party liability add-on cover shall cover bodily injury or death suffered by third parties (including the Employer's personnel) and loss of or damage to property (including the Employer's property and any parts of the Facilities which have been accepted by the Employer) occurring in connection with supply and installation of the Facilities.

- V. The cost of insurance premium is to be reimbursed to the Contractor for Employer Supplied Materials (OSM) for which the insurer is to be finalized by the Contractor as detailed therein. Alternatively, the Contractor may take a single policy covering the entire cost of the project including the cost of OSM. For this purpose, the Contractor shall submit documentary evidence for the premium paid for the entire project to the Employer and Employer shall reimburse to the Contractor the proportion of premium equal to value of OSM to total sum insured.
- VI. If during the execution of Contract, the Employer requests the Contractor to take any other add-on cover(s)/ supplementary cover(s) in aforesaid insurance, in such a case, the Contractor shall promptly take such add-on cover(s)/ supplementary cover(s) and the charges towards such premium for such add-on cover(s)/ supplementary cover(s) shall be reimbursed to the Contractor on submission documentary evidence of payment to the Insurance company. Therefore, charges towards premium for such add-on cover(s)/ supplementary cover(s) are not included in the Contract Price.

c) Automobile Liability Insurance

The Contractor shall ensure that all the vehicles deployed by the Contractor or its SubContractors (whether or not owned by them) in connection with the supply and installation of the Facilities in the project are duly insured as per RTA act. Further the Contractor or its SubContractors may also take comprehensive policy (own damage plus third party liability) of each individual vehicles deployed in the project on their own discretion in their own name to protect their own interest.

d) Workmen Compensation Policy:



- I. Workmen Compensation Policy shall be taken by the Contractor in accordance with the statutory requirement applicable in India. The Contractor shall ensure that all the workmen employed by the Contractor or its SubContractors for the project are adequately covered under the policy.
  
- II. The policy may either be project specific covering all men of the Contractor and its SubContractors. The policy shall be kept valid till the date of Operational Acceptance of the project.

Alternatively, if the Contractor has an existing 'Workmen Compensation Policy' for all its employees including that of the SubContractor(s), the Contractor must include the interest of the Employer for this specific Project in its existing 'Workmen Compensation Policy'.

- III. Without relieving the Contractor of its obligations and responsibilities under this Contract, before commencing work the Contractor shall insure against liability for death of or injury to persons employed by the Contractor including liability by statute and at common law. The insurance cover shall be maintained until all work including remedial work is completed including the Defect Liability Period. The insurance shall be extended to indemnify the Principal for the Principal's statutory liability to persons employed by the Contractor.

The Contractor shall also ensure that each of its SubContractors shall effect and maintain insurance on the same basis as the 'Workmen Compensation Policy' effected by the Contractor.

e) Contractor's Plant and Machinery (CPM) Insurance

The Employer (including without limitation any consultant, servant, agent or employee of the Employer) shall not in any circumstances be liable to the Contractor for any loss of or damage to any of the Contractor's Equipment or for any losses, liabilities, costs, claims, actions or demands which the Contractor may incur or which may be made against it as a result of or in connection with any such loss or damage.

f) Other Insurances

Such other insurances as may be specifically agreed upon by the Parties hereto as listed in the Appendix to the Contract Agreement titled Insurance Requirements.

34.2 The Employer shall be named as co-insured under all insurance policies taken out by the Contractor pursuant to GCC Sub-Clause 34.1, except for the Third Party Liability, Workers' Compensation and Employer's Liability Insurances, and the Contractor's SubContractors shall be named as co-insureds under all insurance policies taken out by the Contractor pursuant to GCC Sub-Clause 34.1 except for the Cargo Insurance During Transport, Workers' Compensation and Employer's Liability Insurances. All insurer's rights of subrogation against such co-insureds for losses or claims arising out of the performance of the Contract shall be waived under such policies.

34.3 The Contractor shall, in accordance with the provisions of the Appendix to the Contract Agreement titled Insurance Requirements, deliver to the Employer certificates of insurance or copies of the insurance policies as evidence that the required policies are in full force and effect. The certificates shall provide that no less than twenty-one (21) days' notice shall be given to the Employer by insurers prior to cancellation or material modification of a policy.

34.4 The Contractor shall ensure that, where applicable, its SubContractor(s) shall take out and maintain in effect adequate insurance policies for their personnel and vehicles and for work executed by them under the Contract, unless such SubContractors are covered by the policies taken out by the Contractor.

34.5 If the Contractor fails to take out and/or maintain in effect the insurances referred to in GCC Sub-Clause 34.1, the Employer may take out and maintain in effect any such insurances and may from time to time deduct from any amount due the Contractor under the Contract any premium that the Employer shall have paid to the insurer, or may otherwise recover such amount as a debt due from the Contractor

34.6 Unless otherwise provided in the Contract, the Contractor shall prepare and conduct all and any claims made under the policies effected by it pursuant to this GCC Clause 34, and all monies payable by any insurers shall be paid to the Contractor. The Employer shall give to the Contractor all such reasonable assistance as may be required by the Contractor. With respect to insurance claims in which the Employer's interest is involved, the Contractor shall not give any release or make any compromise with the insurer without the prior written consent of the Employer. With respect to insurance claims in which the Contractor's interest is involved, the Employer shall not give any release or make any compromise with the insurer without the prior written consent of the Contractor.

**35. Unforeseen Conditions** 35.1 If, during the execution of the Contract, the Contractor shall encounter on the Site any physical conditions other than climatic conditions, or artificial obstructions that could not have been reasonably foreseen prior to the date of the Contract Agreement by an experienced Contractor on the basis of reasonable examination of the data relating to the Facilities including any data as to boring tests, provided by the Employer, and on the basis of information that it could have obtained from a visual inspection of the Site if access thereto was available, or other data readily available to it relating to the Facilities, and if the Contractor determines that it will in consequence of such conditions or obstructions incur additional cost and expense or require additional time to perform its obligations under the Contract that would not have been required if such physical conditions or artificial obstructions had not been encountered, the Contractor shall promptly, and before performing additional work or using additional Plant or Contractor's Equipment, notify the Project Manager in writing of

- (a) the physical conditions or artificial obstructions on the Site that could not have been reasonably foreseen;
- (b) the additional work and/or Plant and/or Contractor's Equipment required, including the steps which the Contractor will or proposes to take to overcome such conditions or obstructions;
- (c) the extent of the anticipated delay; and
- (d) the additional cost and expense that the Contractor is likely to incur.

On receiving any notice from the Contractor under this GCC Sub-Clause 35.1, the Project Manager shall promptly consult with the Employer and Contractor and decide upon the actions to be taken to overcome the physical conditions or artificial obstructions encountered. Following such consultations, the Project Manager shall instruct the Contractor, with a copy to the Employer, of the actions to be taken.

- 35.2 Any reasonable additional cost and expense incurred by the Contractor in following the instructions from the Project Manager to overcome such physical conditions or artificial obstructions referred to in GCC Sub-Clause 35.1 shall be paid by the Employer to the Contractor as an addition to the Contract Price. However the Employer's decision in this regard shall be final and binding.

If the Contractor is delayed or impeded in the performance of the Contract because of any such physical conditions or artificial obstructions referred to in GCC Sub-Clause 35.1, the Time for Completion shall be extended in accordance with GCC Clause 40.

### **36. Change in Laws and Regulations**

- 36.1 If, after the date twenty-eight (28) days prior to the date of Bid submission, in India, any law, regulation, ordinance, order or by-law having the force of law is enacted, promulgated, abrogated or changed which shall be deemed to include any change in interpretation or application by the competent authorities, that subsequently affects the costs and expenses of the Contractor and/or the Time for Completion, the Contract Price shall be correspondingly increased or decreased, and/or the Time for Completion shall be reasonably adjusted to the extent that the Contractor has thereby been

affected in the performance of any of its obligations under the Contract. Notwithstanding the foregoing, such additional or reduced costs shall not be separately paid or credited if the same has already been accounted for in the price adjustment provisions where applicable, in accordance with the SCC pursuant to GCC Sub-Clause 11.2 or under other provisions of the Contract.

### **37. Force Majeure**

37.1 “Force Majeure” shall mean any event beyond the reasonable control of the Employer or of the Contractor, as the case may be, and which is unavoidable notwithstanding the reasonable care of the Party affected, and shall include, without limitation, the following:

- (a) war, hostilities or warlike operations whether a state of war be declared or not, invasion, act of foreign enemy and civil war
- (b) rebellion, revolution, insurrection, mutiny, usurpation of civil or military government, conspiracy, riot, civil commotion and terrorist acts
- (c) confiscation, nationalization, mobilization, commandeering or requisition by or under the order of any government or de jure or de facto authority or ruler or any other act or failure to act of any local state or national government authority
- (d) strike, sabotage, lockout, embargo, import restriction, port congestion, lack of usual means of public transportation and communication, industrial dispute, shipwreck, shortage or restriction of power supply, epidemics, quarantine and plague
- (e) earthquake, landslide, volcanic activity, fire, flood or inundation, tidal wave, typhoon or cyclone, hurricane, storm, lightning, or other inclement weather condition, nuclear and pressure waves or other natural or physical disaster
- (f) shortage of labor, materials or utilities where caused by circumstances that are themselves Force Majeure.

- 37.2 If either Party is prevented, hindered or delayed from or in performing any of its obligations under the Contract by an event of Force Majeure, then it shall notify the other in writing of the occurrence of such event and the circumstances thereof within fourteen (14) days after the occurrence of such event.
- 37.3 The Party who has given such notice, unless disputed by the other Party, shall be excused from the performance or punctual performance of its obligations under the Contract for so long as the relevant event of Force Majeure continues and to the extent that such Party's performance is prevented, hindered or delayed. The Time for Completion shall be extended in accordance with GCC Clause 40.
- 37.4 The Party or Parties affected by the event of Force Majeure shall use reasonable efforts to mitigate the effect thereof upon its or their performance of the Contract and to fulfill its or their obligations under the Contract, but without prejudice to either Party's right to terminate the Contract under GCC Sub-Clauses 37.6 and 38.5.
- 37.5 No delay or nonperformance by either Party hereto caused by the occurrence of any event of Force Majeure shall
- (a) constitute a default or breach of the Contract, or
  - (b) give rise to any claim for damages or additional cost or expense occasioned thereby, subject to GCC Sub-Clauses 32.2, 38.3 and 38.4
- if and to the extent that such delay or nonperformance is caused by the occurrence of an event of Force Majeure.
- 37.6 If the performance of the Contract is substantially prevented, hindered or delayed for a single period of more than ninety (90) days or an aggregate period of more than one hundred and eighty (180) days on account of one or more events of Force Majeure during the currency of the Contract, the Parties will attempt to develop a mutually satisfactory solution, failing which either Party may terminate the Contract by giving a notice to the other, but without prejudice to either Party's right to terminate the Contract under GCC Sub-Clause 38.5.

37.7 In the event of termination pursuant to GCC Sub-Clause 37.6, the rights and obligations of the Employer and the Contractor shall be as specified in GCC Sub-Clauses 42.1.2 and 42.1.3.

37.8 Notwithstanding GCC Sub-Clause 37.5, Force Majeure shall not apply to any obligation of the Employer to make payments to the Contractor herein.

### **38. War Risks**

38.1 “War Risks” shall mean any event specified in paragraphs (a) and (b) of GCC Sub-Clause 37.1 and any explosion or impact of any mine, bomb, shell, grenade or other projectile, missile, munitions or explosive of war, occurring or existing in the India impacting the Site.

38.2 Notwithstanding anything contained in the Contract, the Contractor shall have no liability whatsoever for or with respect to

- (a) destruction of or damage to Facilities, Plant, or any part thereof;
- (b) destruction of or damage to property of the Employer or any third Party; or
- (c) injury or loss of life

if such destruction, damage, injury or loss of life is caused by any War Risks, and the Employer shall indemnify and hold the Contractor harmless from and against any and all claims, liabilities, actions, lawsuits, damages, costs, charges or expenses arising in consequence of or in connection with the same.

38.3 If the Facilities or any Plant shall sustain destruction or damage by reason of any War Risks, the Employer shall pay the Contractor for

- (a) any part of the Facilities or the Plant so destroyed or damaged to the extent not already paid for by the Employer

and so far as may be required by the Employer, and as may be necessary for completion of the Facilities; and

- (b) replacing or making good any such destruction or damage to the Facilities or the Plant or any part thereof .

If the Employer does not require the Contractor to replace or make good any such destruction or damage to the Facilities, the Employer shall either request a change in accordance with GCC Clause 39, excluding the performance of that part of the Facilities thereby destroyed or damaged or, where the loss, destruction or damage affects a substantial part of the Facilities, shall terminate the Contract, pursuant to GCC Sub-Clause 42.1.

If the Employer requires the Contractor to replace or make good on any such destruction or damage to the Facilities, the Time for Completion shall be extended in accordance with GCC 40.

38.4 Notwithstanding anything contained in the Contract, the Employer shall pay the Contractor for any increased costs or incidentals to the execution of the Contract, to the extent reasonable, that are in any way attributable to, consequent on, resulting from, or in any way connected with any War Risks, provided that the Contractor shall as soon as practicable notify the Employer in writing of any such increased cost.

38.5 If during the performance of the Contract any War Risks shall occur that financially or otherwise materially affect the execution of the Contract by the Contractor, the Contractor shall use its reasonable efforts to execute the Contract with due and proper consideration given to the safety of its and its SubContractors' personnel engaged in the work on the Facilities, provided, however, that if the execution of the work on the Facilities becomes impossible or is substantially prevented for a single period of more than ninety (90) days or an aggregate period of more than one hundred and eighty (180) days on account of any War Risks, the Parties will attempt to develop a mutually satisfactory solution, failing which either Party may terminate the Contract by giving a notice to the other.

38.6 In the event of termination pursuant to GCC Sub-Clauses 38.3 or 38.5, the rights and obligations of the Employer and the Contractor shall be specified in GCC Sub-Clauses 42.1.2 and 42.1.3.

## **H. Change in Contract Elements**



**39. Change in the Facilities**

39.1 The Employer shall have the right to propose, and subsequently require, that the Project Manager order the Contractor from time to time during the performance of the Contract to make any change, modification, addition or deletion to, in or from the Facilities hereinafter called “Change”, provided that such Change falls within the general scope of the Facilities and does not constitute unrelated work and that it is technically practicable, taking into account both the state of advancement of the Facilities and the technical compatibility of the Change envisaged with the nature of the Facilities as specified in the Contract.

39.2 Notwithstanding GCC Sub-Clauses 39.1, no change made necessary because of any default of the Contractor in the performance of its obligations under the Contract shall be deemed to be a Change, and such change shall not result in any adjustment of the Contract Price or the Time for Completion.

39.3 The pricing of any Change shall, as far as practicable, be calculated in accordance with the rates and prices included in the Contract.

39.4 Employer has the right to introduce a Change by issuing an amendment to the Contract and amending the Contract Price, by varying the quantities of items originally included in the priced Schedule of Items and Bill of Quantities forming part of the Contract, within the limit as specified in SCC at the unit rates of the items specified in the Contract.

**40. Extension of Time for Completion**

40.1 The Time(s) for Completion specified in the SCC pursuant to GCC Sub-Clause 8.2 shall be extended if the Contractor is delayed or impeded in the performance of any of its obligations under the Contract by reason of any of the following:

- (a) any Change in the Facilities as provided in GCC Clause 39 except if otherwise stated therein.
- (b) any occurrence of Force Majeure as provided in GCC Clause 37, unforeseen conditions as provided in GCC Clause 35, or other

occurrence of any of the matters specified or referred to in paragraphs (a), (b) and (c) of GCC Sub-Clause 32.2

- (c) any suspension order given by the Employer under GCC Clause 41 hereof or reduction in the rate of progress pursuant to GCC Sub-Clause 41.2 or
- (d) any changes in laws and regulations as provided in GCC Clause 36 or
- (e) any default or breach of the Contract by the Employer, or any activity, act or omission of the Employer, or the Project Manager, or any other Contractors employed by the Employer, or
- (f) any delay on the part of a SubContractor, provided such delay is due to a cause for which the Contractor himself would have been entitled to an extension of time under this sub-clause, or
- (g) delays attributable to the Employer or caused by customs, or
- (h) any other matter specifically mentioned in the Contract

by such period as shall be fair and reasonable in all the circumstances and as shall fairly reflect the delay or impediment sustained by the Contractor.

- 40.2 Except where otherwise specifically provided in the Contract, the Contractor shall submit to the Project Manager a notice of a claim for an extension of the Time for Completion, together with particulars of the event or circumstance justifying such extension as soon as reasonably practicable after the commencement of such event or circumstance. As soon as reasonably practicable after receipt of such notice and supporting particulars of the claim, the Employer and the Contractor shall agree upon the period of such extension. In the event that the Contractor does not accept the Employer's estimate of a fair and reasonable time extension, the Contractor shall be entitled to refer the matter for settlement of dispute in accordance with GCC Sub-Clause 46.

40.3 The Contractor shall at all times use its reasonable efforts to minimize any delay in the performance of its obligations under the Contract.

40.4 In all cases where the Contractor has given a notice of a claim for an extension of time under GCC 40.2, the Contractor shall consult with the Project Manager in order to determine the steps (if any) which can be taken to overcome or minimize the actual or anticipated delay. The Contractor shall there after comply with all reasonable instructions which the Project Manager shall give in order to minimize such delay. If compliance with such instructions shall cause the Contractor to incur extra costs and the Contractor is entitled to an extension of time under GCC 40.1, the amount of such extra costs shall be added to the Contract Price.

#### **41. Suspension**

41.1 The Employer may request the Project Manager, by notice to the Contractor, to order the Contractor to suspend performance of any or all of its obligations under the Contract. Such notice shall specify the obligation of which performance is to be suspended, the effective date of the suspension and the reasons therefor. The Contractor shall thereupon suspend performance of such obligation, except those obligations necessary for the care or preservation of the Facilities, until ordered in writing to resume such performance by the Project Manager.

If, by virtue of a suspension order given by the Project Manager, other than by reason of the Contractor's default or breach of the Contract, the Contractor's performance of any of its obligations is suspended for an aggregate period of more than ninety (90) days, then at any time thereafter and provided that at that time such performance is still suspended, the Contractor may give a notice to the Project Manager requiring that the Employer shall, within twenty-eight (28) days of receipt of the notice, order the resumption of such performance or request and subsequently order a change in accordance with GCC Clause 39, excluding the performance of the suspended obligations from the Contract.

If the Employer fails to do so within such period, the Contractor may, by a further notice to the Project Manager, elect to treat the suspension, where it affects a part only of the Facilities, as a deletion of such part in accordance with GCC Clause 39 or,

where it affects the whole of the Facilities, as termination of the Contract under GCC Sub-Clause 42.1.

41.2 If

- (a) the Employer has failed to pay the Contractor any sum due under the Contract for considerable period beyond the specified period, has failed to approve any invoice or supporting documents without just cause pursuant to the Appendix to the Contract Agreement titled Terms and Procedures of Payment, or commits a substantial breach of the Contract, the Contractor may give a notice to the Employer that requires payment of such sum, with interest thereon as stipulated in GCC Sub-Clause 12.3, requires approval of such invoice or supporting documents, or specifies the breach and requires the Employer to remedy the same, as the case may be. If the Employer fails to pay such sum together with such interest, fails to approve such invoice or supporting documents or give its reasons for withholding such approval, or fails to remedy the breach or take steps to remedy the breach within fourteen (14) days after receipt of the Contractor's notice or
- (b) the Contractor is unable to carry out any of its obligations under the Contract for any reason attributable to the Employer, including but not limited to the Employer's failure to provide possession of or access to the Site or other areas in accordance with GCC Sub-Clause 10.2, or failure to obtain any governmental permit necessary for the execution and/or completion of the Facilities,

then the Contractor may by fourteen (14) days' notice to the Employer suspend performance of all or any of its obligations under the Contract, or reduce the rate of progress.

- 41.3 If the Contractor's performance of its obligations is suspended or the rate of progress is reduced pursuant to this GCC Clause 41, then the Time for Completion shall be extended in accordance with GCC Sub-Clause 40.1, and any and all additional costs or expenses incurred by the Contractor as a result of such suspension or reduction, provided that the

Contractor's performance of any of its obligations is suspended for an aggregate period of more than ninety (90) days, then for the time of suspension thereafter and provided that at that time such performance is still suspended, shall be paid by the Employer to the Contractor in addition to the Contract Price, except in the case of suspension order or reduction in the rate of progress by reason of the Contractor's default or breach of the Contract.

41.4 During the period of suspension, the Contractor shall not remove from the Site any Plant, any part of the Facilities or any Contractor's Equipment, without the prior written consent of the Employer.

## **42. Termination**

### **42.1 Termination for Employer's Convenience**

42.1.1 The Employer may at any time terminate the Contract for any reason by giving the Contractor a notice of termination that refers to this GCC Sub-Clause 42.1.

42.1.2 Upon receipt of the notice of termination under GCC Sub-Clause 42.1.1, the Contractor shall either immediately or upon the date specified in the notice of termination

- (a) cease all further work, except for such work as the Employer may specify in the notice of termination for the sole purpose of protecting that part of the Facilities already executed, or any work required to leave the Site in a clean and safe condition
- (b) terminate all subcontracts, except those to be assigned to the Employer pursuant to paragraph (d) (ii) below
- (c) remove all Contractor's Equipment from the Site, repatriate the Contractor's and its SubContractors' personnel from the Site, remove from the Site any wreckage, rubbish and debris of any kind, and leave the whole of the Site in a clean and safe condition, and
- (d) subject to the payment specified in GCC Sub-Clause 42.1.3,

- (i) deliver to the Employer the parts of the Facilities executed by the Contractor up to the date of termination
- (ii) to the extent legally possible, assign to the Employer all right, title and benefit of the Contractor to the Facilities and to the Plant as of the date of termination, and, as may be required by the Employer, in any subcontracts concluded between the Contractor and its SubContractors; and
- (iii) deliver to the Employer all non-proprietary drawings, specifications and other documents prepared by the Contractor or its SubContractors as at the date of termination in connection with the Facilities.

42.1.3 In the event of termination of the Contract under GCC Sub-Clause 42.1.1, the Employer shall pay to the Contractor the following amounts:

- (a) the Contract Price, properly attributable to the parts of the Facilities executed by the Contractor as of the date of termination
- (b) the costs reasonably incurred by the Contractor in the removal of the Contractor's Equipment from the Site and in the repatriation of the Contractor's and its SubContractors' personnel
- (c) any amounts to be paid by the Contractor to its SubContractors in connection with the termination of any subcontracts, including any cancellation charges
- (d) costs incurred by the Contractor in protecting the Facilities and leaving the Site in a clean and safe condition pursuant to paragraph (a) of GCC Sub-Clause 42.1.2

- (e) the cost of satisfying all other obligations, commitments and claims that the Contractor may in good faith have undertaken with third Parties in connection with the Contract and that are not covered by paragraphs (a) through (d) above.

#### 42.2 Termination for Contractor's Default

42.2.1 The Employer, without prejudice to any other rights or remedies it may possess, may terminate the Contract forthwith in the following circumstances by giving a notice of termination and its reasons therefor to the Contractor, referring to this GCC Sub-Clause 42.2:

- (a) if the Contractor becomes bankrupt or insolvent, has a receiving order issued against it, compounds with its creditors, or, if the Contractor is a corporation, a resolution is passed or order is made for its winding up, other than a voluntary liquidation for the purposes of amalgamation or reconstruction, a receiver is appointed over any part of its undertaking or assets, or if the Contractor takes or suffers any other analogous action in consequence of debt
- (b) if the Contractor assigns or transfers the Contract or any right or interest therein in violation of the provision of GCC Clause 43.
- (c) if the Contractor, in the judgment of the Employer has engaged in Fraud and Corruption, as defined in Attachment 1 to the GCC, in competing for or in executing the Contract.

#### 42.2.2 If the Contractor

- (a) has abandoned or repudiated the Contract
- (b) has without valid reason failed to commence work on the Facilities promptly or has suspended, other than pursuant to GCC Sub-Clause 41.2, the

progress of Contract performance for more than twenty-eight (28) days after receiving a written instruction from the Employer to proceed

- (c) persistently fails to execute the Contract in accordance with the Contract or persistently neglects to carry out its obligations under the Contract without just cause
- (d) refuses or is unable to provide plant, equipment, goods, materials, services or labor sufficient to execute and complete the Facilities in the manner specified in the program furnished under GCC Sub-Clause 18.2 at rates of progress that give reasonable assurance to the Employer that the Contractor can attain Completion of the Facilities by the Time for Completion as extended,

then the Employer may, without prejudice to any other rights it may possess under the Contract including encashment of Performance and other securities, give a notice to the Contractor stating the nature of the default and requiring the Contractor to remedy the same. If the Contractor fails to remedy or to take steps to remedy the same within fourteen (14) days of its receipt of such notice, then the Employer may terminate the Contract forthwith by giving a notice of termination to the Contractor that refers to this GCC Sub-Clause 42.2.

42.2.3 Upon receipt of the notice of termination under GCC Sub-Clauses 42.2.1 or 42.2.2, the Contractor shall, either immediately or upon such date as is specified in the notice of termination,

- (a) cease all further work, except for such work as the Employer may specify in the notice of termination for the sole purpose of protecting that part of the Facilities already executed, or any work required to leave the Site in a clean and safe condition



- (b) terminate all subcontracts, except those to be assigned to the Employer pursuant to paragraph (d) below
- (c) deliver to the Employer the parts of the Facilities executed by the Contractor up to the date of termination
- (d) to the extent legally possible, assign to the Employer all right, title and benefit of the Contractor to the Facilities and to the Plant as of the date of termination, and, as may be required by the Employer, in any subcontracts concluded between the Contractor and its SubContractors
- (e) deliver to the Employer all drawings, specifications and other documents prepared by the Contractor or its SubContractors as of the date of termination in connection with the Facilities.

42.2.4 The Employer may enter upon the Site, expel the Contractor, and complete the Facilities itself or by employing any third Party. The Employer may, to the exclusion of any right of the Contractor over the same, take over and use with the payment of a fair rental rate to the Contractor, with all the maintenance costs to the account of the Employer and with an indemnification by the Employer for all liability including damage or injury to persons arising out of the Employer's use of such equipment, any Contractor's Equipment owned by the Contractor and on the Site in connection with the Facilities for such reasonable period as the Employer considers expedient for the supply and installation of the Facilities.

Upon completion of the Facilities or at such earlier date as the Employer thinks appropriate, the Employer shall give notice to the Contractor that such Contractor's Equipment will be returned to the Contractor at or near the Site and shall return such Contractor's Equipment to the Contractor in accordance with such notice. The Contractor shall

thereafter without delay and at its cost remove or arrange removal of the same from the Site.

42.2.5 Subject to GCC Sub-Clause 42.2.6, the Contractor shall be entitled to be paid the Contract Price attributable to the Facilities executed as of the date of termination, the value of any unused or partially used Plant on the Site, and the costs, if any, incurred in protecting the Facilities and in leaving the Site in a clean and safe condition pursuant to paragraph (a) of GCC Sub-Clause 42.2.3. Any sums due the Employer from the Contractor accruing prior to the date of termination shall be deducted from the amount to be paid to the Contractor under this Contract.

42.2.6 If the Employer completes the Facilities, the cost of completing the Facilities by the Employer shall be determined.

If the sum that the Contractor is entitled to be paid, pursuant to GCC Sub-Clause 42.2.5, plus the reasonable costs incurred by the Employer in completing the Facilities, exceeds the Contract Price, the Contractor shall be liable for such excess.

If such excess is greater than the sums due the Contractor under GCC Sub-Clause 42.2.5 and any other monies otherwise due to the Contractor under the Contract, and including remittances, if any, received by the Employer through securities furnished by the Contractor, the Contractor shall pay the balance to the Employer, and if such excess is less than the sums as aforesaid, the Employer shall pay the balance to the Contractor.

The Employer and the Contractor shall agree, in writing, on the computation described above and the manner in which any sums shall be paid.

### 42.3 Termination by the Contractor

42.3.1 The Contractor may terminate the Contract forthwith by giving a notice to the Employer to that effect, referring to this GCC Sub-Clause 42.3.1, if the Employer becomes bankrupt or insolvent, has a receiving order issued against

it, compounds with its creditors, or, being a corporation, if a resolution is passed or order is made for its winding up (other than a voluntary liquidation for the purposes of amalgamation or reconstruction), a receiver is appointed over any part of its undertaking or assets, or if the Employer takes or suffers any other analogous action in consequence of debt.

42.3.2 If the Contract is terminated under GCC Sub-Clauses 42.3.1, then the Contractor shall immediately

- (a) cease all further work, except for such work as may be necessary for the purpose of protecting that part of the Facilities already executed, or any work required to leave the Site in a clean and safe condition
- (b) terminate all subcontracts, except those to be assigned to the Employer pursuant to paragraph (d) (ii)
- (c) remove all Contractor's Equipment from the Site and repatriate the Contractor's and its SubContractors' personnel from the Site, and
- (d) subject to the payment specified in GCC Sub-Clause 42.3.3,
  - (i) deliver to the Employer the parts of the Facilities executed by the Contractor up to the date of termination
  - (ii) to the extent legally possible, assign to the Employer all right, title and benefit of the Contractor to the Facilities and to the Plant as of the date of termination, and, as may be required by the Employer, in any subcontracts concluded between the Contractor and its SubContractors, and
  - (iii) deliver to the Employer all drawings, specifications and other documents prepared by the Contractor or its SubContractors

as of the date of termination in connection with the Facilities.

42.3.3 If the Contract is terminated under GCC Sub-Clauses 42.3.1 , the Employer shall pay to the Contractor all payments specified in GCC Sub-Clause 42.1.3, and reasonable compensation for all loss, except for loss of profit, or damage sustained by the Contractor arising out of, in connection with or in consequence of such termination.

42.3.4 Termination by the Contractor pursuant to this GCC Sub-Clause 42.3 is without prejudice to any other rights or remedies of the Contractor that may be exercised in lieu of or in addition to rights conferred by GCC Sub-Clause 42.3.

42.4 In this GCC Clause 42, the expression “Facilities executed” shall include all work executed, Installation Services provided, and all Plant acquired, or subject to a legally binding obligation to purchase, by the Contractor and used or intended to be used for the purpose of the Facilities, up to and including the date of termination.

42.5 In this GCC Clause 42, in calculating any monies due from the Employer to the Contractor, account shall be taken of any sum previously paid by the Employer to the Contractor under the Contract, including any advance payment paid pursuant to the Appendix to the Contract Agreement titled Terms and Procedures of Payment.

### **43. Assignment**

43.1 Neither the Employer nor the Contractor shall, without the express prior written consent of the other Party, which consent shall not be unreasonably withheld, assign to any third Party the Contract or any part thereof, or any right, benefit, obligation or interest therein or thereunder.

## **I. Claims, Disputes and Arbitration**

### **44. Contractor’s Claims**

44.1 If the Contractor considers himself to be entitled to any extension of the Time for Completion and/or any additional payment, under any Clause of these Conditions or otherwise in connection with the Contract, the Contractor shall submit a notice to the Project Manager, describing the event or

circumstance giving rise to the claim. The notice shall be given as soon as practicable, and not later than 28 days after the Contractor became aware, or should have become aware, of the event or circumstance.

If the Contractor fails to give notice of a claim within such period of 28 days, the Time for Completion shall not be extended, the Contractor shall not be entitled to additional payment, and the Employer shall be discharged from all liability in connection with the claim. Otherwise, the following provisions of this Sub-Clause shall apply.

The Contractor shall also submit any other notices which are required by the Contract, and supporting particulars for the claim, all as relevant to such event or circumstance.

The Contractor shall keep such contemporary records as may be necessary to substantiate any claim, either on the Site or at another location acceptable to the Project Manager. Without admitting the Employer's liability, the Project Manager may, after receiving any notice under this Sub-Clause, monitor the record-keeping and/or instruct the Contractor to keep further contemporary records. The Contractor shall permit the Project Manager to inspect all these records, and shall (if instructed) submit copies to the Project Manager.

Within 42 days after the Contractor became aware (or should have become aware) of the event or circumstance giving rise to the claim, or within such other period as may be proposed by the Contractor and approved by the Project Manager, the Contractor shall send to the Project Manager a fully detailed claim which includes full supporting particulars of the basis of the claim and of the extension of time and/or additional payment claimed. If the event or circumstance giving rise to the claim has a continuing effect:

- (a) this fully detailed claim shall be considered as interim;
- (b) the Contractor shall send further interim claims at monthly intervals, giving the accumulated delay and/or amount claimed, and such further

particulars as the Project Manager may reasonably require; and

- (c) the Contractor shall send a final claim within 28 days after the end of the effects resulting from the event or circumstance, or within such other period as may be proposed by the Contractor and approved by the Project Manager.

Within 42 days after receiving a claim or any further particulars supporting a previous claim, or within such other period as may be proposed by the Project Manager and approved by the Contractor, the Project Manager shall respond with approval, or with disapproval and detailed comments. He may also request any necessary further particulars, but shall nevertheless give his response on the principles of the claim within such time.

The requirements of this Sub-Clause are in addition to those of any other Sub-Clause which may apply to a claim. If the Contractor fails to comply with this or another Sub-Clause in relation to any claim, any extension of time and/or additional payment shall take account of the extent (if any) to which the failure has prevented or prejudiced proper investigation of the claim, unless the claim is excluded under the second paragraph of this Sub-Clause.

In the event that the Contractor and the Employer cannot agree on any matter relating to a claim, either Party may refer the matter for settlement of dispute pursuant to GCC 46 hereof.

#### **45. Disputes and Arbitration**

- 45.1 The Parties shall seek to resolve any dispute amicably by mutual consultation. If either Party objects to any action or inaction of the other Party, the objecting Party may file a written Notice of Dispute to the other Party providing in detail the basis of the dispute. The Party receiving the Notice of Dispute will consider it and respond in writing within fourteen (14) days after receipt. If that Party fails to respond within fourteen (14) days, or the dispute cannot be amicably settled within fourteen (14) days following the response of that Party, Clause **GCC 45.2** shall apply. The Parties shall use their best efforts to settle amicably all disputes arising out of or in connection with this Contract or its interpretation.

45.2 If, the parties have failed to resolve their dispute or difference by such mutual consultation as per Clause **GCC 45.1**, then either the Employer or the Contractor may give notice to the other party of its intention to commence conciliation/ arbitration, as hereinafter provided, as to the matter in dispute, and no conciliation/ arbitration in respect of this matter may be commenced unless such notice is given. Any dispute or difference in respect of which a notice of intention to commence conciliation/ arbitration has been given in accordance with this Clause shall be finally settled in accordance with the following provisions:

(i) Disputes shall be settled through conciliation or arbitration in accordance with Arbitration and Conciliation Act, 1996 including amendments thereto, as applicable from time to time, in accordance with the rules thereto and the Applicable Law.

In any arbitration proceeding hereunder:

- (a) proceedings shall be held in the place mentioned in **SCC** which shall be the seat as well as the venue of arbitration except otherwise agreed by the Parties.
- (b) English language shall be the official language for all purposes; and
- (c) the decision of the sole arbitrator or of a majority of the arbitrators (or of the third arbitrator if there is no such majority) shall be final and binding and shall be enforceable in the court of competent jurisdiction in India, as per the Applicable Law

45.3 Notwithstanding any dispute and/or reference to conciliation/ arbitration herein,

- (a) the parties shall continue to perform their respective obligations under the Contract unless they otherwise agree; and  
the Purchaser shall pay the Supplier any monies due to the Supplier.

## J. Additional

### 46. Up-front intimation of approved manufacturers and criterion for Fresh Vendor approval

46.1 Employer shall up-front intimate list containing name of already approved vendors/manufacturers of various sub-transmission and distribution materials. Employer shall up-load the list on their web portal. The turnkey Contractor shall choose one or more than one vendors from the pre-approved lists depending upon capacity and capability of vendors to supply the materials for RDSS works. No separate approval for vendor shall be required from Employer.

Also, normal procedure being followed for empanelment of new vendors shall be uploaded and up-front intimated to all turnkey Contractors. In case turnkey Contractor desires to add new vendor, up-front intimation shall be available on criterion and procedure for selection of vendors.

### 47. Up-front intimation of Guaranteed Technical Particulars

47.1 Technical Specifications are enclosed with the bid documents. Employer shall up-front intimate acceptable Guaranteed Technical Particulars of various materials through their web portal.

47.2 The turnkey Contractor will examine these documents and supply only those materials which meets the above acceptable criterion. In case there are Employer's approved vendor(s) (one or more) through which turnkey Contractor wish to procure the materials and are complying with the acceptable GTP parameters of Employer as available on their web portal, there would not be any formality needed like approval of sub-vendor or approval of GTP again.

47.3 In event of change in name of vendor or change in GTP parameter, separate approval of Employer shall be sought by successful turnkey Contractor.

### 48. Turnkey Contractor's Store at Project site

48.1 ~~“Project wise separate Site Stores shall be maintained and manned by turnkey Contractor. Same store shall not be used for more than one projects even if neighboring districts' projects are awarded to the same agency. The turnkey Contractor shall deploy his own manpower in stores for round the clock security and for its day to day operation through trained Store-keeper.~~



~~Since materials received in this stores are owned by Employer (including owner's free issued material) and are pre dispatch inspected by Employer's representative/ or NABL lab inspected, materials in a lot shall not be issued to the sub-Contractor for physical execution by turnkey Contractor. Instead, day to day requirements shall be issued to the working teams of sub-vendors by authorized store-keeper. In exceptional cases, on prior written permission of Employer, materials for a week time may be issued to working team of sub-vendor. Daily accounting of materials receipt, materials issues, materials in custody of sub-vendors are to be maintained by turnkey Contractor. Handing of Stores shall, in no circumstances, be off loaded.~~

~~In no case, inter-project transfer of materials shall be permitted.~~

#### **49. Handing over of assets**

~~49.1 On completion of erection and testing of a section of line, DTR substation, power substation, contracting agency shall submit digital photographs in soft copies of each and every support structures along with submission of completion report in support of their claim for energisation and handing over of assets. In addition, Contractor shall also ensure 100% tagging of assets on GIS portal provided by Employer. The Mobile App for GIS asset tagging shall be provided by the Employer. Project Manager within a week time, shall review the photographs for acceptance of quality of works and shall immediately deploy officials for joint measurement and inspection of executed works for energisation. In parallel, a requisition to State Electrical Inspectorate shall also be submitted by Project Manager. Fee/Charges for inspection by electrical inspector shall be paid by Project Manager (Employer).~~

~~While offering section of work / substation for commissioning and handing over, turnkey Contractor shall provide pre-commissioning test reports and detailed checklist (format provided along with quality guidelines at Part 2: Section 6).~~

## **50. Supply of Materials in lots**

50.1 ~~Item wise mobilization of materials shall be planned in [6 lots or as decided by the Employer]. Employer shall arrange pre dispatch inspections for at least [6 lots or as decided by the Employer] at his own expenditure. However, in case of approved quantity variation, employer may consider to increase the number of Lots. In addition, Employer shall also ensure that samples (as per IS Sampling standard) from 01<sup>st</sup> lot and one other lot randomly selected by the Employer will be sent to nearest NABL accredited lab approved by the employer for testing directly from the manufacturing unit. TkC shall incur the expenses of testing. During the Pre-Dispatch inspection of materials, Contractor shall also mandatorily send its authorized person in the manufacturing facility. The authorized person of Contractor shall also sign the joint inspection report along with the Employer. All such cost shall be borne by the Contractor.~~

## **51. Contract Closing**

- 51.1 On completion of handing over formality and successfully completion of defect liability / guarantee period, the contract shall be closed on completion of following formality:
- I. Material reconciliation of owner free issued materials as well as material supplied by turnkey Contractor,
  - II. Payment reconciliations, submission and verifications that reconciliation of payment toward statutory provisions like GST, any other dues etc. Reconciliation statement shall be verified and vetted by chartered accountant.
  - III. Approval for extension of Completion period, with or without compensation, as required.
  - IV. Certification from agency regarding payment of dues to its
    - i. Sub-vendors
    - ii. Workers/ contract laborers,
    - iii. Payment of statutory dues toward Provident Funds, wages etc. as required.
  - V. Certification of Project Manager & agency to the effect that erection, testing and commissioning of the equipment have been completed as per specifications laid down in the contract and defects noted at the time of commissioning and

notified to the agency have been liquidated to the satisfaction of Employer.

- VI. Removal of construction meant for site stores, hutment, labour colony etc. in the premises of EMPLOYER.
- VII. Certificate from Project Manager in charge regarding final amendment of drawings and detailed of such amendments,
- VIII. Drawing receipt certificate by the Project Manager,
- IX. Receipt of compliance report on Quality Assurance Mechanism along with photograph, Assurance documents by Project Manager
- X. Shortfall in equipment / Line performance Certificate issued by Project Manager,
- XI. No demand certificate issued by Contractor,
- XII. Certificate about completion of Defect Liability Period of the package by Project Manager,
- XIII. Certificate regarding return of Performance Security / Indemnity Bond by Project Manager/Employer.

## **52. Suspension of business dealings**

52.1 Employer shall suspend business dealings with Contractor on following grounds for the period as decided by Project Manager:-

- a. If the Contractor fails to submit Performance Security after issuance of Letter of Intent (LoI) within 28 days.
- b. If the Contractor fails to accept the award of contract or has abandoned or repudiated the Contract.
- c. If the Contractor is found to be non-performing in execution of contract by the Employer.
- d. If a disaster / major failure / accident / collapse of a structure / system is caused during erection or during defect liability period due to negligence of Contractor or design deficiency or poor quality of execution.
- e. Misbehavior or physical manhandling by the Contractor or his representative or any person acting on his behalf with any official

of the Company dealing with the concerned contract is established.

- f. If the Director / Owner of the Contractor, proprietor or partner of the Contractor, is convicted by a court of law for offences involving corrupt and fraudulent practices including moral turpitude in relation to its business dealings with the government or State Public Sector Undertakings or Central Public Sector Undertakings or Employer or Employer's group companies, during the last five years.
- g. If the proprietors of the Contractor have been guilty of malpractices such as bribery, corruption, fraud, substitution of the tenders, interpolations, etc.
- h. If the Contractor continuously refuses to return / refund the dues of Employer or Employer's group companies, without showing adequate reason and this is not due to any reasonable dispute which would attract proceedings in arbitration or court of Law;
- i. If the Contractor employs a public servant dismissed / removed or employs a person convicted for an offence involving corruption or abetment of such offences;
- j. If business dealings with the Contractor have been banned by the Ministry of Power or Government of India or any Government from any foreign country listed by ADB and the ban is still in force,
- k. If it is established that Contractor has resorted to corrupt, fraudulent practices including misrepresentation of facts;
- l. If the Contractor uses intimidation/threatening or brings undue outside pressure on the Project Manager or his authorised representatives or its

officials in acceptance / performance of the job under the contract.

- m. If the Contractor indulges in repeated and / or deliberate use of delay tactics in complying with contractual stipulations;
- n. If the Contractor is found to be involved in cartel formation during bidding.
- o. On willful indulgence by the Contractor in supplying sub-standard material with respect to Technical Specifications under the Contract irrespective of whether pre-dispatch inspection was carried out by Employer or not;
- p. If the Contractor is declared bankrupt or insolvent or its financial position has become unsound, and in the case of a limited company, it is wound up or liquidated.
- q. Established litigant nature of the Contractor to derive undue benefit;
- r. Continued poor performance of the Contractor;
- s. If the Contractor violates the provisions of the Integrity Pact provided in the Contract.
- t. If the Contractor commits fraud as defined under the Fraud Prevention Policy of Employer.
- u. If the Contractor has assigned or transferred the contract or engaged subcontractor(s) without the prior approval of the Competent Authority in violation of the provisions of the contract.
- v. If the Contractor misuses the premises or facilities of the Employer, forcefully occupies, tampers or damages the Employer's properties including land, water resources, forests / trees, etc.

- w. If the security consideration, including questions of loyalty of the Contractor to the state, so warrants;

## **ATTACHMENT 1 to GCC**

### **Fraud and Corruption**

#### 1. Purpose

1.1 Government's/ WBSEDCL's Anti-Corruption Laws/ Guidelines apply with respect to procurement.

#### 2. Requirements

2.1 WBSEDCL requires that bidders (applicants/proposers), consultants, Contractors and suppliers; any sub-Contractors, sub-consultants, service providers or suppliers; any agents (whether declared or not); and any of their personnel, observe the highest standard of ethics during the procurement process, selection and contract execution, and refrain from Fraud and Corruption.

2.2 To this end, WBSEDCL:

- I. Defines, for the purposes of this provision, the terms set forth below as follows:
  - i. "corrupt practice" is the offering, giving, receiving, or soliciting, directly or indirectly, of anything of value to influence improperly the actions of another party;
  - ii. "fraudulent practice" is any act or omission, including misrepresentation, that knowingly or recklessly misleads, or attempts to mislead, a party to obtain financial or other benefit or to avoid an obligation;
  - iii. "collusive practice" is an arrangement between two or more parties designed to achieve an improper purpose, including to influence improperly the actions of another party;
  - iv. "coercive practice" is impairing or harming, or threatening to impair or harm, directly or indirectly, any party or the property of the party to influence improperly the actions of a party;
  - v. "obstructive practice" is:
    - (a) deliberately destroying, falsifying, altering, or concealing of evidence material to the investigation or making false statements to investigators in order to materially impede investigation into allegations of a corrupt, fraudulent, coercive, or collusive practice; and/or threatening, harassing, or intimidating any party to prevent it from disclosing its knowledge of matters relevant to the investigation or from pursuing the investigation; or
- II. Rejects a proposal (also referred to as the bid) for award if the WBSEDCL determines that the firm or individual recommended for award, any of its personnel, or its agents, or its sub-consultants, sub-Contractors, service providers, suppliers and/ or their employees, has, directly or indirectly, engaged in corrupt, fraudulent, collusive, coercive, or obstructive practices in competing for the contract in question.
- III. In addition to the legal remedies set out in the relevant Legal Agreement, may take other appropriate actions,;
- IV. Pursuant to the Anti- Corruption Laws/ Guidelines and in accordance with due process, WBSEDCL, may sanction a firm or individual, either indefinitely or for a stated period

of time, including by publicly declaring such firm or individual ineligible (i) to be awarded or otherwise benefit from contract awarded by WBSEDCL or its subsidiaries/ affiliates, financially or in any other manner; (ii) to be a nominated sub-Contractor, consultant, manufacturer or supplier, or service provider of an otherwise eligible firm being awarded a contract WBSEDCL or its subsidiaries/ affiliates; and (iii) to receive the proceeds of any loan made by the WBSEDCL or otherwise to participate further in the preparation or implementation of any WBSEDCL project.

- V. And the bidders (applicants/proposers), Consultants, Contractors, service providers and suppliers have entered into **Integrity Pact** which shall also apply in addition to the aforesaid.



## Special Conditions of Contract

Number of GCC Clause	Amendments of, and Supplements to, Clauses in the General Conditions of Contract (GCC)		
GCC 1.1	<p>Mode of contracting is as under:</p> <p>1. The Contract is entered into between the Employer and the Contractor as under:</p> <p>(i) Contract Part I (<i>Supply of Plant Contract</i>): for Supply of Plant on FOR (final place of destination Site/ Project Site) basis inter alia including design, engineering, manufacture, testing, transportation, insurance etc. and other services, incidental thereto, as applicable,</p> <p>(ii) Contract Part II (<i>Supply of Services Contract</i>): For providing all services inter alia, including unloading and handling of Plant, all labor, Contractor's equipment, temporary works, materials, consumables, design and preparation of layout, engineering drawings, and all matters and things of whatsoever nature, including testing, pre-commissioning and commissioning, operations and maintenance services, the provision of as-built drawings, operations and maintenance manuals, training, etc., as specified in Contract and applicable and necessary for the proper execution of the Installation Services (but excluding the incidental to supply under Contract Part I) and other services, related to and incidental to successful installation of the Plant supplied under the "Contract Part I", at final destination (Site/ Project Site).</p> <p>2. The award of two separate Contract parts shall not in any way dilute the responsibility of the Contractor for the successful completion of the Facilities as per Contract and Specification and a breach in one part of the Contract shall automatically be construed as a breach of the other part of the Contract which will confer a right on the Employer to terminate the Contract at the risk and the cost of the Contractor.</p> <p>3. The Contract will be signed in two originals and the Contractor shall be provided with one signed original and the other will be retained by the Employer.</p> <p>4. If required by the Employer, the Contractor shall provide free of cost to the Employer all the engineering data, drawing and descriptive materials etc. submitted with its Bid, in at least two (2) copies to form a part of the Contract.</p>		
GCC 1.1	The Employer is: <i>WEST BENGAL STATE ELECTRICITY DISTRIBUTION COMPANY LTD. (WBSEDCL)</i> .		
GCC 1.1	The Project Manager is: The successful Bidder shall appoint a Project Manager and a SPOC for project after award of Contract. This shall be intimated to WBSEDCL in writing by the successful Bidder after award of Contract.		
GCC 1.1	Name	Utility	WBSEDCL Project Manager Office Address

	<b>Infrastructure Upgradation in DC/DRC in WBSEDCL</b>	WBSEDCL	Office of the Chief Engineer IT&C Cell , 3 <sup>rd</sup> Floor, Block-C&D Vidyut Bhavan, Salt Lake . Kolkata
<b>GCC 6.1</b>	Integrity Pact is applicable as indicated in <b>Attachment 1 to the GCC.</b>		
<b>GCC 7.3</b>	Supply spare-parts have to be followed as per WBSEDCL approved GTP & drawing		
<b>GCC 8.1</b>	Commencement of work from the date of issuance of Notification of Award i.e. <b>Zero Date.</b>		
<b>GCC 8.2</b>	24 Months		
<b>GCC 11.2</b>	<p>The Contract Price is subject to adjustment during performance of the contract to reflect changes in the cost elements such as labor, material, transport and Contractor's equipment in accordance with the procedures specified in the corresponding <b>Appendix to the Contract Agreement</b> as per which the contract price for specified goods/ equipment/ material shall be adjustable as per the method and procedures for the price adjustment specified therein. <i>{Appendix 2 of Form 5 in Section – 8 of the RFB/ bidding documents}</i>.</p> <p>The Contract Price is subject to alteration in the event of a Change in the Facilities as per GCC 39, through an amendment to the Contract.</p>		
<b>GCC 13.3.1</b>	<ol style="list-style-type: none"> <li>1. The Performance Security amount is 10% of Contract Price, and the Standard Form of Performance Security acceptable to the Employer shall be as specified in <b>Section 8.</b> Contract Forms.</li> <li>2. The Additional Performance Security amount is 10% of the level of unbalancing, pursuant to ITB clause 37.1 and 44.1 ...e.g., the percentage of the supply price more than the percentage specified in the said clause limited to 70% (Seventy Percent) of the total Contract Price including supply and</li> </ol>		

	<p>erection, and the Standard Form of Performance Security acceptable to the Employer shall be as specified in <b>Section 8</b>. Contract Forms.</p> <ol style="list-style-type: none"> <li>3. Validity of additional performance security related to level of unbalancing as defines in ITB-37 under BDS should be 180 days beyond defect liability period. The validity and methodology of additional performance security will be same as performance security.</li> <li>4. The Contractor/Bidder shall, within twenty-eight (28) days of the notification of contract award, provide a security in an amount equal to 100% of the advance payment calculated in accordance with the Appendix to the Contract Agreement titled Terms and Procedures of Payment, and in the same currency or currencies.</li> </ol>
<b>GCC 13.3.2</b>	<p>The Bank Guarantee towards Performance Security shall be issued by a Bank mentioned below:</p> <p>Any Scheduled Bank in India</p>
<b>GCC 14.2</b>	<p>Only GST applicable in India, on the Plant and Installation Services provided/supplied by the Contractor to the Employer under the Contract shall be paid/reimbursed by Employer against requisite documents, at actuals. BOCW Cess will be applicable as per act. GST will be applicable as per GST Act in India.</p>
<b>GCC 19.3</b>	<p>Any subcontract of value equal to more than 5% shall necessarily require prior approval of the Employer. However, sub-contract for engagement of labour shall not require prior approval of the Employer.</p>
<b>GCC 23</b>	<p><b>1) Category — A (Pre-Dispatch Inspection &amp; Testing at NABL accredited Labs):</b></p> <ol style="list-style-type: none"> <li>a) <del>This category shall include high ticket materials (Power Transformers, Distribution Transformers, Circuit Breakers, AB/XLPE Cables, Overhead Conductor (AAAC/ACSR), Insulator which involves more and important testing procedures and hence the inspection of these materials will be carried out in the factory before the dispatch of the material.</del></li> <li>b) <del>In addition, Employer shall also ensure that for major materials as discussed above, samples from 1st lot and one other lot randomly selected by the Employer shall be directly sent to NABL accredited test labs for third party testing. It is also to be noted that material clearance of the lots under testing shall only be given post receipt of successful test results. Contractor shall also mandatorily depute its authorized official for pre — dispatch inspection at manufacturing facility along with the Employer officials. The inspection and testing report would be jointly signed by the Employer and the Contractor. All the expenses related to testing would be borne by the Contractor.</del></li> <li>c) <del>Apart from the above mentioned protocol any one power transformer shall be selected by Employer from the supply schedule from the vendor, which shall be jointly sealed and tested for short circuit testing on turnkey Contractor's expenses.</del></li> </ol>

~~2) Category – B (On-site inspection): This category includes the materials for which a factory inspection is not warranted and the material can be inspected upon arrival at the site before the installation. In case the Employer is apprehensive about the quality of the material supplied it reserves the right to send the selected lot to the NABL accredited testing lab for third party testing.~~

~~3) Employer also reserves the right to send any installed equipment / materials to the NABL accredited testing lab for testing. The Employer would have to reimburse the expenses related to transportation of material from site to testing lab and all testing expenses in this regard.~~

~~4) The material which has to be tested at laboratory shall be sealed in the presence of authorized official of Employer and Contractor.~~

~~5) If the materials tested at Laboratory fails then the entire lot would be rejected. Contractor shall bear the responsibility of sending back such failed materials from site. Any subsequent delay in contract performance due to failure of materials in the test laboratory would be on account of Contractor and no time extension would be provided by the Employer in this regard. Any LD levies in this regard would be borne by the Contractor.~~

**~~Pre-dispatch Inspection:~~**

~~Pre-dispatch inspection shall be performed on various materials at manufacturer's work place for which Contractor shall be required to raise requisition giving at least 10 day time to employer for allocating inspection team. Depending on requirement, inspection shall be witnessed by representatives of Employer, TPIA and Contractor/Bidder.~~

~~The Contractor shall ensure receipt of material at site within 21 days from date of receipt of dispatch instructions. In case materials are not received within 21 days from date of issue of dispatch instruction, the dispatch instruction shall stand cancelled and a fresh pre-dispatch would be required to issue dispatch instruction. All expenditure incurred by Employer in performance of dispatch instruction shall be recovered from turnkey Contractor.~~

~~The turnkey Contractor shall ensure that pre-dispatch inspection for materials is intimated only when the material is completely ready for inspection. On due date of inspection, if it is found that materials are not ready in required quantities or the inspection could not be carried out due to non-availability of requisite calibrated certificate of instruments with manufacturer, closing of works on scheduled date of inspection, non-availability of sufficient testing/material handling staff at manufacturer works etc., all expenditures incurred on deployment of various inspecting officials along with a fine of Rs 50,000/ inclusive of GST shall be recovered from the bills of the agency and re-inspection shall be carried out on expense of Contractor.~~

~~2nd such situation at same manufacturer/supplier shall result in rejection of name of manufacturer from list of approved vendors/sub-vendors. In case sub-standard materials (old component, re-cycled materials, re-used core material, re-used transformer coil material etc.) offered for inspection and are noticed during the~~

~~inspection, materials shall be rejected, and approval of sub-vendor shall also be cancelled for all RDSS projects.~~

~~In case, a material fails the pre-dispatch inspection as per GCC Clause 23, and also fails the subsequent repeat inspection of the rectified/replaced material, the complete lot of material under inspection will be required to be replaced by the manufacturer/supplier. If in subsequent inspection of the new lot, the material again fails the inspection, then materials shall be rejected and approval of vendor/sub-vendor shall also be cancelled for all RDSS projects.~~

~~Third Party Inspection at NABL accredited lab: Employer shall also ensure that for major materials as discussed above samples from 1st lot and one other lot randomly selected by the Employer shall be directly sent to nearest NABL accredited lab for third party testing. In case a material fails in the test, the whole offered lot would be rejected and complete lot of material under inspection will be required to be replaced by the manufacturer/supplier. If in subsequent inspection of the new lot, the material again fails the inspection, then materials shall be rejected and the vendor/sub-vendor shall also be debarred for all RDSS projects. In case of default by vendors/manufacturers, Contractor/Bidder shall also be penalized as per below table:~~

<del>Sr. No.</del>	<del>No. of Material/lot rejected in a project/district</del>	<del>% Penalty imposed on contract price of that particular material, line item of LOA.</del>
<del>1</del>	<del>≥5</del>	<del>5%</del>
<del>2</del>	<del>≥3</del>	<del>2.5%</del>
<del>3</del>	<del>≥1</del>	<del>1%</del>

**~~Penalty provision for defects found in Field inspection:~~**

~~There are three categories of defects if be found against erection of electrical items during field inspection shall be categorized as **critical, major and minor** defects. There should be a provision to impose penalty on Contractor based on the percentage of major/critical defects observed by TPQMA.~~

<del>Sr. No.</del>	<del>Defect criteria</del>	<del>% Penalty imposed on Sanctioned Cost</del>
<del>1</del>	<del>Critical Defects</del>	<del>1%</del>
<del>2</del>	<del>Major Defects</del>	<del>0.5%</del>
<del>3</del>	<del>Minor Defects</del>	<del>0% if rectified within 30 days</del>

**~~Electrical Inspector inspection:~~**

~~After successful completion of the work permission from State Electrical Inspectorate is required. Necessary fee etc. shall be paid by the Employer. However if Contractor pays such fee it shall be reimbursed on actual basis on documentary evidence.~~

~~Defects / in-complete works notified by Electrical Inspectorate shall be completed by the agency at no extra cost implication to Employer.~~

<b>GCC 26.2</b>	If the Contractor fails to attain Completion of the Facilities or any part thereof within the Time for Completion or any extension thereof under GCC Clause 40, the Contractor shall pay to the Employer liquidated damages at 0.15% for each week or part thereof, of the value of unexecuted works. The value of unexecuted works shall be equal to the difference of 1. The approved value of the surveyed & approved BOQ (inclusive of GST) and 2. The value of executed works (total billed amount only, inclusive of GST).till the time for completion or any extension thereof under GCC clause 40. The aggregate amount of such liquidated damages shall in no event exceed 5% of the value of unexecuted works (inclusive of GST). Once the “Maximum” is reached, the Employer may consider termination of the Contract, pursuant to GCC Sub-Clause 42.2.2.
<b>GCC 27.1</b>	<p>(a) Volume of concreting: If it was observed by employer, quality monitoring agencies and/or REC/MoP that volume and quality of concreting used in foundation of support, equipment foundation, gantry structure foundation, stay set etc. are not as per requirement specified in the scope of work/technical specifications, the Contractor has to dismantle the supports, foundation and redo the concreting of all the supports in that particular section of line/redo all the foundations in that particular substation at his own cost. To ensure this, the employer reserves the right to withhold the payment of Contractor for such defective works till such time the Contractor conforms to scope of works, technical specification and tender drawings.</p> <p>(b) Galvanization of metallic structure: All Metallic structures &amp; fabricated items excluding metallic supports (Steel tubular poles/H-Beam) must be galvanized. In case any metallic item found rusted during execution of works, the Contractor has to replace the item used at all places. To ensure this, the employer reserves the right to withhold the payment of Contractor for such works till such time the Contractor conforms to scope of works, technical specification and tender drawings.</p> <p>(c) Painting of metallic supports (Steel tubular poles/H-Beam): Painting of metallic supports in overhead lines, distribution transformer substation and Power substation shall be ensured as per specifications. In case metallic supports found rusted during execution of works, the Contractor has to remove inferior painting, clean the surface and re-paint it as per given specifications. To ensure this, the employer reserves the right to withhold the payment of Contractor for such works till such time the Contractor conforms to scope of works, technical specification and tender drawings.</p>
<b>GCC 27.8</b>	<p>The extension of Defect Liability Period, in aggregate, shall, not exceed <b>36 months</b>.</p> <p>The bidder should submit an undertaking in non-judicial stamp paper (Rs.100/-) for providing Latent Defect Coverage support warranty against each equipments and it shall be limited to period specified in SCC/Technical Specifications, reckoned from the end of defect liability period including extension thereof and the related format is enclosed herewith as Form-21.</p>
<b>GCC 27.8.1</b>	The Contractor's liability for latent defects warranty shall be limited to <b>5 years</b> reckoned from the end of Defect Liability Period including extension thereof.

<b>GCC 39.4</b>	<p>The quantity of items given in the Price Schedules forming part of the Contract are provisional. The variation in quantity of the items shall be within the limit of plus/minus (+/-) fifty percent (50%) for individual items. In case the quantity variation of the individual items is beyond the limit specified above, the unit rates for the quantity beyond the said limit, shall be mutually agreed based on prevailing market rates as may be fair and reasonable.</p> <p>It is to be noted that Employer may choose to approve a variation of upto 20% of contract value (calculated using the rates quoted at the time of bidding) which has been caused due to quantity variation. For variation of greater than 20% but less than 50% of contract value(calculated using the rates quoted at the time of bidding), Employer will need to take DRC approval for approving the said quantity variation.</p>
<b>GCC 45.2 (a)</b>	Hon'ble Calcutta High Court.
<b>Additional Clause</b>	<b>The predefined phasing of works</b> -As per mutually approved L1 & L2 PERT Chart between EPC Contractor & Employer.

---

**Section - 8 : Contract Forms**



## 2. BID SECURITY FORM

*(To be stamped in accordance with Stamp Act, the Non-Judicial Stamp Paper should be in the name of the issuing Bank)*

Bank Guarantee No.: .....

Date: .....

To: *(insert Name and Address of Employer)*

WHEREAS M/s. .... *(insert name of Bidder)*..... having its Registered/Head Office at .... *(insert address of the Bidder)* ..... *(hereinafter called "the Bidder")* has submitted its Bid for the performance of the Contract for.....*(insert name of the Package)*.....*under*.....*(insert Specification No)*..... *(hereinafter called "the Bid")*

KNOW ALL PERSONS by these present that WE .....*(insert name & address of the issuing bank)* ..... having its Registered/Head Office at .....*(insert address of registered office of the bank)*..... *(hereinafter called "the Bank")*, are bound unto .....*(insert name of Employer)*..... *(hereinafter called "the Employer")* in the sum of .....*(insert amount of Bid Security in figures & words)*.....  
..... for which payment well and truly to be made to the said Employer, the Bank binds itself, its successors and assigns by these presents.

Sealed with the Common Seal of the said Bank this ..... day of ..... 20....

THE CONDITIONS of this obligation are:

- (1) If the Bidder withdraws its bid during the period of bid validity specified by the Bidder in the Bid Form; or
- (2) In case the Bidder does not withdraw the deviations proposed by him, if any, at the cost of withdrawal stated by him in the bid and/or accept the withdrawals/rectifications pursuant to the declaration/confirmation made by him in Attachment – Declaration of the Bid; or
- (3) If the Bidder does not accept the corrections to arithmetical errors identified during preliminary evaluation of his bid pursuant to ITB Clause 33.1; or
- (4) If, as per the requirement of Qualification Requirements the Bidder is required to submit a Deed of Joint Undertaking and he fails to submit the same, duly attested

by Notary Public of the place(s) of the respective executant(s) or registered with the Indian Embassy/High Commission in that Country, within ten days from the date of intimation of post – bid discussion; or

(5) in the case of a successful Bidder, if the Bidder fails within the specified time limit

(i) to sign the Contract Agreement, in accordance with ITB Clause 43, or

(ii) to furnish the required performance security, in accordance with ITB Clause 44.  
or

(6) In any other case specifically provided for in ITB.

WE undertake to pay to the Employer up to the above amount upon receipt of its first written demand, without the Employer having to substantiate its demand, provided that in its demand the Employer will note that the amount claimed by it is due to it, owing to the occurrence of any of the above-named CONDITIONS or their combination, and specifying the occurred condition or conditions.

This guarantee will remain in full force up to and including .....(*insert date, which shall be the date 30 days after the period of bid validity*)....., and any demand in respect thereof must reach the Bank not later than the above date.

For and on behalf of the Bank

[*Signature of the authorised signatory(ies)*]

Signature\_\_\_\_\_

Name\_\_\_\_\_

Designation\_\_\_\_\_

POA Number\_\_\_\_\_

Contact Number(s): Tel.\_\_\_\_\_ Mobile\_\_\_\_\_

Fax Number\_\_\_\_\_

email \_\_\_\_\_

Common Seal of the Bank\_\_\_\_\_

Witness:

Signature\_\_\_\_\_

Name\_\_\_\_\_

Address\_\_\_\_\_

Contact Number(s): Tel.\_\_\_\_\_ Mobile\_\_\_\_\_

email\_\_\_\_\_

Note:

1. In case the bid is submitted by a Joint Venture(JV), the bid security shall be in the name of the Joint Venture(JV) and not in the name of the Lead Partner or any other Partner(s) of the Joint Venture(JV).
2. The Bank Guarantee should be in accordance with the proforma as provided. However, in case the issuing bank insists for additional paragraph for limitation of liability, the following may be added at the end of the proforma of the Bank Guarantee [*i.e., end paragraph of the Bank Guarantee preceding the signature(s) of the issuing authority(ies) of the Bank Guarantee*]:

Quote

*“Notwithstanding anything contained herein:*

1. *Our liability under this Bank Guarantee shall not exceed \_\_\_\_\_ (value in figures)\_\_\_\_\_ [\_\_\_\_\_ (value in words)\_\_\_\_\_].*
2. *This Bank Guarantee shall be valid upto \_\_\_\_\_(validity date)\_\_\_\_\_.*
3. *We are liable to pay the guaranteed amount or any part thereof under this Bank Guarantee only & only if we receive a written claim or demand on or before \_\_\_\_\_ (validity date) \_\_\_\_\_.”*

Unquote

**3a. FORM OF NOTIFICATION BY THE EMPLOYER TO THE BANK***(Applicable for Forfeiture of Bank Guarantee)*To: *(insert Name and Address of the issuing Bank)*Ref.: Forfeiture of Bid Security Amount against Bank Guarantee No. ....  
dated ..... for ....., issued by you on behalf of M/s. ....*(insert name of the Bidder)* .....

Dear Sirs,

Please refer to the subject Bank Guarantee executed by you in our favour for ..... as Bid Security for the bid submitted by M/s. ....*(insert name of the Bidder)* ..... against ..... *(insert name of the Package)* ..... ; Specification No. ....

As per the terms of the said guarantee, the bank has guaranteed and undertaken to pay immediately on demand by the Employer the amount of ..... without any reservation, protest, demur and recourse. Further, any demand made by the Employer shall be conclusive and binding on the Bank irrespective of any dispute or difference raised by the Bidder.

In terms of the said guarantee, we hereby submit our claim/demand through this letter for remittance of Bid Security amount to .... *(insert name of the Employer)* .....owing to the occurrence of the condition referred to at Sl. No. ....The Bank is requested to remit the full guaranteed sum ..... towards proceeds of the bid security in the form of Demand Draft in favour of ‘.... *(insert name of the Employer)* .....’, payable at ....*(insert place of the Employer)*....’.

Thanking you,

For.....*(Name of the Employer)***(AUTHORISED SIGNATORY)**

Copy to:

.....*(Registered Office of the Bank)*....

**3b. FORM OF NOTIFICATION BY THE EMPLOYER TO THE BANK***(Applicable for conditional claim pending extension of Bank Guarantee by the Bidder)*To: *(insert Name and Address of the issuing Bank)*Ref.: Conditional Claim against Bank Guarantee No. .... dated .....  
for ..... valid up to ..... issued by you on behalf of M/s.  
.....*(insert name of the Bidder)* .....

Dear Sirs,

Please refer to the subject Bank Guarantee executed by you in our favour on behalf of  
M/s. ....*(insert name of the Bidder)* ....., who have submitted this Bank  
Guarantee to us towards Bid Security against .... *(insert name of the Package)* ..... ;  
Specification No. ....

We, ..... *(insert name of the Employer)* ..... do hereby request you to lodge our  
claim/demand against the subject Bank Guarantee for full guaranteed sum. Kindly note  
that this claim/demand against the subject Bank Guarantee is without any further notice in  
case the amendment to Bank Guarantee No. .... dated ..... extending its  
validity upto ..... is not got arranged by .....*(insert name of the Bidder)*  
..... in our favour and are not received by us upto ..... In such an event you  
are requested to remit the full guaranteed amount in terms of the subject guarantee in its  
letter and spirit and proceeds of this Bank Guarantee shall be forwarded to us in form of  
demand draft in favour of ‘ .... *(insert name of the Employer)* ....., payable at ....*(insert  
place of the Employer)*....’.

This is without prejudice to our right under this guarantee and under the law.

Thanking you,

For.....*(Name of the Employer)***(AUTHORISED SIGNATORY)**Copy to:  
*(insert Name and Address of the Bidder)*

- You are requested to do the needful so that the amendment to the subject Bank  
Guarantee extending the validity up to ..... is received by us by .....

#### 4. FORM OF 'NOTIFICATION OF AWARD OF CONTRACT'

##### 4a. FORM OF 'NOTIFICATION OF AWARD OF CONTRACT FOR SUPPLY OF PLANT'

Ref. No. :

Date :

.....(*insert Contractor's Name &Address*).....

.....

.....

.....

*[in case of Joint Venture(JV), the aforesaid details shall be of the Lead Partner and the following shall also be included:*

(Lead Partner of the Joint Venture(JV) of M/s. .... and M/s. ....)]

Attn : Mr.....

Sub. : Notification of Award for Supply of Plant Contract (Contract Part I) for .....  
*(insert name of the Package)* ..... Specification No.:  
 .....National Competitive Bidding. (Project Funding: .....)

### (Contract Part I)

Dear Sir,

#### 1.0 REFERENCE

This has reference to the following:

1.1 Our Request for Bids (RFB) dated .....

1.2 RFB/bidding documents for the subject package issued vide our letter Ref. No. .... dated .....,anddownloaded by you from e-tender portal, comprising the following:

- a) Part 1 : Bidding Procedures and Requirements  
(Document Code No. ....)
- b) Part 2 : Employer's Requirements  
(Document Code No. ....)
- c) Part 3 : Conditions of Contract and Contract Forms  
(Document Code No. ....)

- 1.2.1 Amendment/Errata No. .... to Bidding Documents issued to you vide our letter no. .... dated .....  
*(Applicable only if any Errata/Amendment to the Bidding Documents has been issued subsequently)*
- 1.2.2 Clarifications to the Bidding Documents, pursuant to pre-bid conference held on ....., issued to you vide our letters no. .... dated ..... *(Use as applicable)*  
  
*(Applicable only if any clarification to the Bidding Documents has been issued subsequently)*  
***(INCLUDE AS FURTHER SUB-PARAGRAPHS ANY OTHER CORRESPONDENCE MADE TO THE BIDDER AFTER ISSUANCE OF BIDDING DOCUMENTS UP TO BID OPENING)***
- 1.3 Technical Part (First envelope) of your Bid submitted/the Bid submitted by the Sole/ Bidder/ Lead Joint Venture(JV) Member of M/s. ....(Lead Partner) and M/s. .... (Other Partner) for the subject package under Letter of Bid/Proposal reference no. .... dated ....., which was opened on .....  
*(Use as applicable)*
- 1.4 Intimation for Opening of Financial Part (Second Envelope) of Bid issued to you vide our letter no. .... dated .....
- 1.5 Price Part ( Second Envelope) of your Bid/the Bid by the Sole/ Bidder/ Lead Joint Venture(JV) Member of M/s. .... (Lead Partner) and M/s. .... (Other Partner) under Letter of Bid/ Proposal reference no. .... dated ..... which was opened on.....*(Use as applicable)*
- 1.6 Post bid discussions we had with you on various dates from ..... to ..... resulting into the Minutes of Meeting/ Record Notes of Post Bid Discussions enclosed as APPENDIX (NOA)-1 with this Notification of Award.

## 2.0 **AWARD OF CONTRACT AND ITS SCOPE**

- 2.1 We confirm having accepted your Bid/Bid of the Sole/ Bidder/ Lead Joint Venture(JV) Member of M/s. .... (Lead Partner) and M/s. .... (Other Partner) *(Use as applicable)* (referred to at para 1.3 & 1.5 above) read in conjunction with all the specifications, terms & conditions of the Bidding Documents (referred to at para 1.2, 1.2.1 & 1.2.2 *[modify as applicable]* above) and specific confirmations recorded in the Record Notes of Post Bid Discussions (referred to at para 1.6 above), and award on you/the JOINT

VENTURE(JV)(*use as applicable*) the ‘ Supply of Plant Contract’ (also referred to as the ‘Contract Part I’) covering inter-alia supply of Plant on FOR {final place of destination (Site/ Project Site)} basis inter-alia including design, engineering, manufacture, testing, transportation, insurance etc. and other services, incidental thereto, , required for the complete execution of the ..... (*insert name of Package along with name of the Project*) ....., as detailed in the documents referred hereinabove. The scope of work inter-alia includes the following:

..... (Indicate brief Scope of Work) .....

The scope of work under this Notification of Award (NOA) shall also include all such items which are not specifically mentioned in the bidding documents and/or your bid but are necessary for the successful completion of your scope under the Contract for the construction of ..... (*insert name of Package along with name of the Project*) ....., unless otherwise specifically excluded in the Bidding Documents or in this NOA.

2.1.1 You, the Lead Partner of the JOINT VENTURE(JV), along with M/s. ...., the Other Partner of JOINT VENTURE(JV), shall be liable jointly and severally for the execution of the Contract in accordance with terms and conditions of the Contract. As per the Power of Attorney furnished in your favour by the Joint Venture(JV), as enclosed with Bid Proposal of the JOINT VENTURE(JV), you shall act as the Partner In-charge (Lead Partner) of the above Joint Venture(JV) for execution of the Contract. (*This provision shall be included only in case the Bidder is a Joint Venture(JV)*)

2.2 The notification for award of Contract for performance of all other Installation Services/ activities, as set forth in the bidding documents, viz.

..... (*Indicate brief scope of work of the Contract Part II*) .....

has been issued on you vide our NOA no. .... dated ..... (hereinafter called the “Contract Part II” or “ Supply of Installation Services Contract”).

Notwithstanding the award of work for Completion of the Facilities under the Contract in two separate parts in the aforesaid manner, you/the JOINT VENTURE(JV) (*use as applicable*) shall be overall responsible to ensure the execution of both the parts of the Contract to achieve successful completion and taking over of the Facilities/Works under the package by the Employer as per the requirements stipulated in the Bidding Documents. It is expressly understood and agreed by you/the JOINT VENTURE(JV) (*use as applicable*) that any default or breach under the ‘Contract Part II’ shall automatically be deemed as a default or breach of this ‘Contract Part I’ also and vice-versa, and any such default or breach or occurrence giving us a right to terminate the ‘Contract Part II’, either in full or in



part, and/or recover damages there under, shall give us an absolute right to terminate this Contract Part I, at your/JOINT VENTURE(JV)'s (*use as applicable*) risk, cost and responsibility, either in full or in part and/or recover damages under this 'Contract Part I' as well. However, such default or breach or occurrence in the 'Contract Part II', shall not automatically relieve you/the JOINT VENTURE(JV) (*use as applicable*) of any of your/JOINT VENTURE(JV)'s (*use as applicable*) obligations under this 'Contract Part I'. It is also expressly understood and agreed by you/the JOINT VENTURE(JV) (*use as applicable*) that the Plant/equipment/goods/ materials supplied by you/the JOINT VENTURE(JV) (*use as applicable*) under this 'Contract Part I', when erected, installed & commissioned by you under the 'Contract Part II' shall give satisfactory performance in accordance with the provisions of the Contract.

### 3.0 CONTRACT PRICE FOR CONTRACT PART I

- 3.1 The total Contract Price for Contract Part I for the entire scope of work under this Contract Part I shall be .....(*Specify the currency and the amount in figures & words*) ..... as per the following break-up:

Sl. No.	Price Component	Amount
1.	FOR Price component	_____
<b>Total for Supply of Plant Contract</b>		_____

- 3.2 Notwithstanding the break-up of the Contract Price, the Contract shall, at all times, be construed as a single source responsibility Contract and any breach in any part of the Contract shall be treated as a breach of the entire Contract.
- 4.0 You/The JOINT VENTURE(JV) (*use as applicable*)are/is required to furnish at the earliest a Performance Security(ies), as per the Bidding Documents, for an amount of ..... (*Specify the value*) ..... i.e. equal to [10% (Ten percent)] of the Contract Price, and valid upto and including ..... and any other securities as per the Bidding Documents.  
(*In case any other performance security is required to be furnished, the same is to be mentioned here*)
- 5.0 For release of advance payment (admissible as per the Bidding Documents) equal to .....% of the FOR Price component of the Contract Price for Contract part I, you are, inter-alia, required to furnish a Bank Guarantee for the 100% of the advance amount. The validity of the Advance Bank Guarantee shall be up to and including ..... Further, please note that furnishing of all the Contract Performance Securities under the 'Contract Part I' and 'Contract Part II' shall be one of the conditions precedent to release of advance under this Contract Part I.

- 6.0 All the bank guarantees shall be furnished from an eligible bank as described in the Bidding Documents.
- 7.0 The schedule for Taking Over/Completion of Facilities by the Employer upon successful Completion of the ..... (*insert name of Package along with name of the Project*).... shall be ... (*indicate the completion schedule*) ... months from the date of issue of this Notification of Award for all contractual purposes.
- 8.0 This Notification of Award constitutes formation of the Contract and comes into force with effect from the date of issuance of this Notification of Award.
- 9.0 You shall enter into a Contract Agreement with us within twenty-eight (28) days from the date of this Notification of Award.
- 10.0 This Notification of Award is being issued to you in duplicate. We request you to return its duplicate copy duly signed and stamped on each page including the enclosed Appendix as a token of your acknowledgement.

Please take the necessary action to commence the work and confirm action.

Yours faithfully,

For and on behalf of

.....(*Name of the Employer*).....  
(*Authorised Signatory*)

Enclosures:

APPENDIX (NOA) – 1 - Record Notes of Post - Bid Discussions held on various dates from ..... to .....

#### 4b. FORM OF 'NOTIFICATION OF AWARD OF CONTRACT' FOR INSTALLATION OF PLANT AND EQUIPMENT

Ref. No. :

Date :

.....(*insert Contractor's Name &Address*).....

.....

.....

.....

*[in case of Joint Venture(JV), the aforesaid details shall be of the Lead Partner and the following shall also be included:*

(Lead Partner of the Joint Venture(JV) of M/s. .... and M/s. ....)]

Attn : Mr.....

Sub. : Notification of Award for Supply of Installation Services Contract (Contract Part II) for ..... (*insert name of the Package*) ..... Specification No.: ..... Domestic Competitive Bidding. (Project Funding: Domestic).

### **(Contract Part II)**

Dear Sir,

#### 1.0 REFERENCE

This has reference to the following:

1.1 Our Request for Bids (RFB) dated .....

1.2 RFB/ bidding documents for the subject package issued vide our letter Ref. No. .... dated ....., and downloaded by you from e-tender portal, comprising the following:

- a) Part 1 : Bidding Procedures and Requirements  
(Document Code No. ....)
- b) Part 2 : Employer's Requirements  
(Document Code No. ....)
- c) Part 3 : Conditions of Contract and Contract Forms  
(Document Code No. ....)

- 1.2.1 Amendment/Errata No. .... to Bidding Documents issued to you vide our letter no. .... dated .....  
(Applicable only if any Errata/Amendment to the Bidding Documents has been issued subsequently)
- 1.2.2 Clarifications to the Bidding Documents, pursuant to pre-bid conference held on ....., issued to you vide our letters no. .... dated ..... (Use as applicable)  
(Applicable only if any clarification to the Bidding Documents has been issued subsequently)
- (INCLUDE AS FURTHER SUB-PARAGRAPHS ANY OTHER CORRESPONDENCE MADE TO THE BIDDER AFTER ISSUANCE OF BIDDING DOCUMENTS UP TO BID OPENING)*
- 1.3 Technical Part (First envelope) of your Bid submitted/the Bid submitted by the Sole/ Bidder/ Lead Joint Venture(JV) Member of M/s. ....(Lead Partner) and M/s. .... (Other Partner) for the subject package under Letter of Bid/ Proposal reference no. .... dated ....., which was opened on ..... (Use as applicable)
- 1.4 Intimation for Opening of Financial Part (Second Envelope) of Bid issued to you vide our letter no. .... dated .....
- 1.5 Price Part ( Second Envelope) of your our Bid/the Bid by the Sole/ Bidder/ Lead Joint Venture(JV) Member of M/s. .... (Lead Partner) and M/s. .... (Other Partner) under proposal reference no. .... dated ....., which was opened on.....(Use as applicable)
- 1.6 Post bid discussions we had with you on various dates from ..... to ..... resulting into the Minutes of Meeting/ Record Notes of Post Bid Discussions enclosed as APPENDIX (NOA)-1 with this Notification of Award.

## 2.0 AWARD OF CONTRACT AND ITS SCOPE

- 2.1 We confirm having accepted your Bid/Bid of the Sole/ Bidder/ Lead Joint Venture(JV) Member of M/s. .... (Lead Partner) and M/s. .... (Other Partner) (Use as applicable) (referred to at para 1.3 & 1.5 above) read in conjunction with all the specifications, terms & conditions of the Bidding Documents (referred to at para 1.2, 1.2.1 & 1.2.2 [modify as applicable] above) and specific confirmations recorded in the Record Notes of Post Bid Discussions (referred to at para 1.6 above), and award on you/the JOINT

VENTURE(JV)(*use as applicable*) the ‘Supply of Installation Services Contract’ (also referred to as the ‘Contract Part II’) for providing/ supplying all Installation Services (excluding the incidental services included in Contract Part I), interalia, unloading and handling of Plant, all labor, Contractor’s equipment, temporary works, materials, consumables, design and preparation of layout, engineering drawings, and all matters and things of whatsoever nature, including testing, pre-commissioning, guarantee tests and commissioning, the provision of as-built drawings, operations and maintenance manuals, training, etc., applicable and necessary for the proper execution of the installation and other services, at final destination (Site/ Project Site), related to and incidental to successful installation of the Plant supplied under the Contract Part I. as set forth in the bidding documents, viz. .... (*Indicate brief scope of work*) ..... for the ..... (*insert name of Package along with name of the Project*)....

The scope of work under this Notification of Award (NOA) shall also include all such items which are not specifically mentioned in the bidding documents and/or your bid but are necessary for the successful completion of your scope under the Contract for the construction of ..... (*insert name of Package along with name of the Project*) ....., unless otherwise specifically excluded in the bidding documents or in this NOA.

2.1.1 You, the Lead Partner of the JOINT VENTURE(JV), along with M/s. ...., the Other Partner of JOINT VENTURE(JV), shall be liable jointly and severally for the execution of the Contract in accordance with terms and conditions of the Contract. As per the Power of Attorney furnished in your favour by the Joint Venture(JV), as enclosed with Bid Proposal of the JOINT VENTURE(JV), you shall act as the Partner In-charge (Lead Partner) of the above Joint Venture(JV) for execution of the Contract. (*This provision shall be included only in case the Bidder is a Joint Venture(JV)*)

2.2 The notification for award of Contract for Supply of Plant including Type Testing to be conducted, as set forth in the bidding documents, viz.

..... (*Indicate brief scope of work of the Contract Part I*)  
.....

has been issued on you vide our NOA no. .... dated ..... (hereinafter called the “Supply of Plant Contract” or “Contract Part I”).

Notwithstanding the award of work for Completion of the Facilities under the Contract in two separate parts in the aforesaid manner, you/the JOINT VENTURE(JV) (*use as applicable*) shall be overall responsible to ensure the execution of both the parts of the Contract to achieve successful completion and taking over of the Facilities/ works under the package by the Employer as per the

requirements stipulated in the Bidding Documents. It is expressly understood and agreed by you/the JOINT VENTURE(JV)(*use as applicable*) that any default or breach under the ‘Contract Part I’ shall automatically be deemed as a default or breach of this ‘Contract Part II’ also and vice-versa, and any such default or breach or occurrence giving us a right to terminate the ‘Contract Part I’, either in full or in part, and/or recover damages there under, shall give us an absolute right to terminate this Contract Part II, at your/JOINT VENTURE(JV)’s (*use as applicable*) risk, cost and responsibility, either in full or in part and/or recover damages under this ‘Contract Part II’ as well. However, such default or breach or occurrence in the ‘Contract Part I’, shall not automatically relieve you/the JOINT VENTURE(JV)(*use as applicable*) of any of your obligations under this ‘Contract Part II’. It is also expressly understood and agreed by you/the JOINT VENTURE(JV)(*use as applicable*) that the Plant/equipment/goods/ materials supplied by you/the JOINT VENTURE(JV)(*use as applicable*) under the ‘Contract Part I’, when erected, installed & commissioned by you/the JOINT VENTURE(JV)(*use as applicable*) under this ‘Contract Part II’ shall give satisfactory performance in accordance with the provisions of the Contract.

### 3.0 CONTRACT PRICE FOR CONTRACT PART II

- 3.1 The total Contract Price Contract Part II for the entire scope of work under this Contract Part II shall be ..... (*Specify the currency and the amount in figures & words*) ..... as per the following break-up:

Sl. No.	Price Component	Amount
1.	Installation Services	
2.	Training Charges	Not Applicable
<b>Total for Supply of Installation Services Contract</b>		

- 3.2 Notwithstanding the break-up of the Contract Price, the Contract shall, at all times, be construed as a single source responsibility Contract and any breach in any part of the Contract shall be treated as a breach of the entire Contract.
- 4.0 You/the JOINT VENTURE(JV)(*use as applicable*)are/is required to furnish at the earliest a Performance Security(ies), as per the Bidding Documents, for an amount of ..... (*Specify the value*) ..... i.e. equal to [10% (Ten percent)] of the Contract Price, and valid upto and including ..... and any other securities as per the Bidding Documents.

*(In case any other performance security is required to be furnished, the same is to be mentioned here)*

- 5.0 All the bank guarantees shall be furnished from an eligible bank as described in the Bidding Documents.
- 6.0 The schedule for Taking Over/Completion of Facilities by the Employer upon successful Completion of the ..... *(insert name of Package along with name of the Project)* .... shall be ... *(indicate the completion schedule)* .... months from the date of issue of this Notification of Award for all contractual purposes.
- 7.0 This Notification of Award constitutes formation of the Contract and comes into force with effect from the date of issuance of this Notification of Award.
- 8.0 You shall enter into a Contract Agreement with us within twenty-eight (28) days from the date of this Notification of Award.
- 9.0 This Notification of Award is being issued to you in duplicate. We request you to return its duplicate copy duly signed and stamped on each page including the enclosed Appendix as a token of your acknowledgement.

Please take the necessary action to commence the work and confirm action.

Yours faithfully,

For and on behalf of

.....*(Name of the Employer)*.....

*(Authorised Signatory)*

Enclosures:

APPENDIX (NOA) – 1 - Record Notes of Post - Bid Discussions held on various dates from ..... to .....

Note:

- (1) Instructions indicated in italics in this notification of award are to be taken care of by the issuing authority. The Forms may be modified appropriately to suit the specific requirement of the Contract.

## 5. FORM OF CONTRACT AGREEMENT

[Alternative – a]

CONTRACT AGREEMENT PART I FOR SUPPLY OF PLANT BETWEEN.....  
*(Name of Employer)* ..... AND M/s. .... *(Name of Contractor)*  
 ...../SOLE/ BIDDER/ LEAD JOINT VENTURE(JV) MEMBER OF M/s.  
 .....*(Name of Lead Partner)*.... (THE LEAD PARTNER OF THE JOINT  
 VENTURE(JV)) AND M/s. ....*(Name of Other Partner)*..... (THE PARTNER OF THE  
 JOINT VENTURE(JV)) [*Use as applicable*]

THIS CONTRACT AGREEMENT PART I No. .... (also referred to as  
 ‘Supply of Plant Contract/the Contract Part I ’) is made on the .... day of .....  
 20.....

BETWEEN

(1) ..... *(Name of Employer)*..... a company incorporated under the laws  
 of Companies Act 1956/2013 (with amendment from time to time) and having its  
 Registered Office at .....*(registered address of the Employer)* ..... and its  
 Corporate Office at .....*(address of the Employer)*..... (hereinafter called  
 "the Employer" and also referred to as “.....*(insert abbreviated name of the Employer)*  
 .....”)

and

(2) M/s ..... *(Name of Contractor)* ....., a company incorporated under the laws of  
 Companies Act 1956/2013 (with amendment from time to time) and having its Principal  
 place of business at .....*(Address of Contractor)* ..... and Registered  
 Office at .....*(Registered address of Contractor)* ..... (hereinafter called "the  
 Contractor" and also referred to as “.....*(insert abbreviated name of the Contractor)*  
 .....”)

**or**

Sole/ Bidder/ Lead Joint Venture(JV) Member of M/s ..... *(Name of Lead Partner)*  
 ..... (the Lead Partner of JOINT VENTURE(JV)), a company incorporated under  
 the laws of Companies Act 1956 and having its Principal place of business at  
 .....*(Address of Lead Partner)* ..... and Registered Office at  
 .....*(Registered address of Lead Partner)* ..... and M/s ..... *(Name*  
*of Other Partner)* ..... (the Partner of JOINT VENTURE(JV)), a company  
 incorporated under the laws of Companies Act 1956/2013 (with amendment from time to  
 time) and having its Principal place of business at .....*(Address of Other Partner)*  
 ..... and Registered Office at .....*(Registered address of Other*



*Partner*) ..... (hereinafter called "the Contractor" and also referred to as "Joint Venture(JV)" /the 'JOINT VENTURE(JV)')")  
*(Applicable only in case of Joint Venture(JV))*

WHEREAS the Employer desires to engage the Contractor to design, manufacture, test, deliver, install, commission and complete certain Facilities, viz. *[ insert the name of the Package along with ]* ..... ("the Facilities") as detailed in the Contract Document, and the Contractor, in accordance with the mode of contracting specified therein, has agreed to such engagement upon and subject to the terms and conditions appearing in this Contract Agreement Part I for Supply of Plant and in Contract Agreement Part II for Supply of Installation Services for the Facilities, the two parts read together, jointly and in conjunction, constituting the Contract. and the aggregate of the Contract Price for Contract Part I and the Contract Price for Contract Part II constituting the Contract Price for the Contract.

WHERE, the Employer, under this Contract Agreement Part I, desires to engage the Contractor for the supply of Plant on FOR {final place of destination (Site/ Project Site)} basis inter alia including design, engineering, manufacture, testing, transportation, insurance etc. and other services, incidental thereto, required for the complete execution of the ..... *(insert name of Package along with name of the Project)* ....., and the scope of work is briefly described below:

[.....insert brief scope of work .....] ]

NOW IT IS HEREBY AGREED as follows:

#### Article 1. Contract Documents

##### 1.1 Contract Documents (Reference GCC Clause 2)

The following documents shall constitute the Contract between the Employer and the Contractor, and each shall be read and construed as an integral part of the Contract:

#### VOLUME – A

1. This Contract Agreement and the Appendices thereto.
2. Notification of Award Ref. No. .... /NOA-I/01 dated DD/MM/YYYY.

#### VOLUME – B

3. Documents comprising of the following:

- Conditions of Contract and Contract Forms (Part 3 of Bidding Documents)
  - Conditions of Contract including Special Conditions of Contract (SCC) and General Conditions of Contract (GCC); (Section 7 of Bidding Documents)
  - Contract Forms (Section 8 of Bidding Documents)
- Employers' Requirements (Part 2 of Bidding Documents)
  - Employer's Requirements (Section 6 of Bidding Document)
- Bidding Procedures and Requirements (Part 1 of Bidding Documents)
  - Request for Bids Notice (Section 1 of Bidding Documents)
  - Eligibility and Qualification Requirements (Section 2 of Bidding Documents)
  - Instruction to Bidders and Bid Data Sheets (Section 3 of Bidding Documents)

## VOLUME – C

### 4. Bid Submitted by the Contractor.

(Only relevant extracts are attached herewith for easy reference. Should the circumstances warrant, the original Bid along with the enclosures thereof, shall be referred to.).

#### 1.2 Order of Precedence (Reference GCC Clause 2)

In the event of any ambiguity or conflict between the Contract Documents listed above, the order of precedence shall be the order in which the Contract Documents are listed in Article 1.1 (Contract Documents) above.

#### 1.3 Definitions (Reference GCC Clause 1)

Capitalized words and phrases used herein shall have the same meanings as are ascribed to them in the General Conditions of Contract/Special Conditions of Contract.

### Article 2. Contract Price and Terms of Payment

#### 2.1 Contract Price (Reference GCC Clause 11) for Contract Part I

The Employer hereby agrees to pay to the Contractor the Contract Price for Contract Part I in consideration of the performance by the Contractor of its obligations hereunder. The Contract Price for Contract Part I shall be the aggregate of ..... (*amount in words*) ..... (*.....(amount in figures).....*), or such other sums as may be determined in accordance with the terms and conditions of the Contract. The break-up of the Contract Price for Contract Part I is as under:

Sl. No.	Price Component	Amount
1.	FOR Price Component	
Total for Supply of Plant Contract		

The detailed break-up of Contract Price for Contract Part I is given in the relevant Appendices hereto.

## 2.2 Terms of Payment (Reference GCC Clause 12)

The terms and procedures of payment according to which the Employer will reimburse the Contractor are given in Appendix 1 (Terms and Procedures of Payment) hereto.

## Article 3. Effective Date for Determining Time for Completion

### 3.1 Effective Date (Reference GCC Clause 1)

The Effective Date from which the Time for Completion of the Facilities shall be counted and determined is the **date of Notification of the Award**.

## Article 4. Appendices

The Appendices listed in the List of Appendices, as mentioned below, shall be deemed to form an integral part of this Contract Agreement Part I and the Contract.

Reference in this Contract Agreement Part I and the Contract, to any Appendix shall mean and include the Appendices attached hereto, and this Contract Agreement Part I and the Contract shall be read and construed accordingly.

### List of Appendices

Appendix 1	Terms and Procedures of Payment
Appendix 2	Price Adjustment
Appendix 3	Insurance Requirements
Appendix 4	Time Schedule

Appendix 5	List of Approved Subcontractors
Appendix 6	Scope of Works and Supply by the Employer
Appendix 7	List of Document for Approval or Review
Appendix 8	Guarantees, Liquidated Damages for Non-Performance
Appendix 9	Price Schedules indicating Price Breakdown of Contract Price for Contract Part I for Supply of Plant
Appendix 11	Integrity Pact

#### Article 5.

The Contract Agreement Part II No. .... has also been made on the ..... day of ..... 20...., between the Employer and the Contractor for the Supply of Installation Services (hereinafter referred to as the “Contract Part II”) for providing/ supplying all Installation Services (excluding the incidental services included in Contract Part I), interalia, unloading and handling of Plant, all labor, Contractor’s equipment, temporary works, materials, consumables, design and preparation of layout, engineering drawings, and all matters and things of whatsoever nature, including testing, pre-commissioning, guarantee tests and commissioning, the provision of as-built drawings, operations and maintenance manuals, training, etc., applicable and necessary for the proper execution of the installation and other services, at final destination (Site/ Project Site), related to and incidental to successful installation of the Plant supplied under the Contract Part I, required for the complete execution of the ..... (*insert name of Package along with name of the Project*) ....., and the scope of work is briefly described below:

[.....insert brief scope of work.....]

Notwithstanding the award of work for Completion of the Facilities under the Contract in two separate parts in the aforesaid manner, the Contractor shall be overall responsible to ensure the execution of both the parts of the Contract to achieve successful completion and taking over of the Facilities by the Employer as per the requirements stipulated in the Contract. It is expressly understood and agreed by the Contractor that any default or breach under the ‘Contract Part II’ shall automatically be deemed as a default or breach of this ‘Contract Part I’ also and vice-versa and any such breach or occurrence or default giving the Employer a right to terminate the ‘Contract Part II’ either in full or in part, and/or recover damages there under the Contract Part II, shall give the Employer an absolute right to terminate this Contract Part I at the Contractor’s risk, cost and responsibility, either in full or in part and /or recover damages under this ‘Contract Part I’ as well. However, such breach or default or occurrence in the ‘Contract Part II’ shall not automatically relieve the Contractor of any of its responsibility/ obligations under this ‘Contract Part I’. It is also expressly understood and agreed by the Contractor that the Plant/equipment/ goods /materials supplied by the Contractor under this ‘Contract Part I’ when erected, installed and commissioned by the Contractor under

the ‘Contract Part II’ shall give satisfactory performance in accordance with the provisions of the Contract.

IN WITNESS WHEREOF the Employer and the Contractor have caused this Agreement to be duly executed by their duly authorized representatives the day and year first above written.

Signed by for and  
on behalf of the Employer

Signed by for and  
on behalf of the Contractor

.....  
Signature  
.....  
Title  
in the presence of

.....  
Signature  
.....  
Title  
in the presence of

## 5. FORM OF CONTRACT AGREEMENT

[Alternative – b]

CONTRACT AGREEMENT PART II FOR SUPPLY OF INSTALLATION SERVICES BETWEEN ..... (*Name of Employer*) ..... AND M/s. .... (*Name of Contractor*) ...../SOLE/ BIDDER/ LEAD JOINT VENTURE(JV) MEMBER OF M/s. ....(*Name of Lead Partner*).... (THE LEAD PARTNER OF THE JOINT VENTURE(JV)) AND M/s. ....(*Name of Other Partner*)..... (THE PARTNER OF THE JOINT VENTURE(JV)) [*Use as applicable*]

THIS CONTRACT AGREEMENT PART I No. .... (also referred to as 'Supply of Installation Services Contract/the Contract Part II') is made on the .... day of ..... 20.....

BETWEEN

(1) ..... (*Name of Employer*)..... a company incorporated under the laws of Companies Act 1956/2013 (with amendment from time to time) and having its Registered Office at .....(*registered address of the Employer*) ..... and its Corporate Office at .....(*address of the Employer*)..... (hereinafter called "the Employer" and also referred to as “.....(*insert abbreviated name of the Employer*) .....”)

and

(2) M/s ..... (*Name of Contractor*) ....., a company incorporated under the laws of Companies Act 1956/2013 (with amendment from time to time) and having its Principal place of business at .....(*Address of Contractor*) ..... and Registered Office at .....(*Registered address of Contractor*) ..... (hereinafter called "the Contractor" and also referred to as “.....(*insert abbreviated name of the Contractor*) .....”)

**or**

Sole/ Bidder/ Lead Joint Venture(JV) Member of M/s ..... (*Name of Lead Partner*) ..... (the Lead Partner of JOINT VENTURE(JV)), a company incorporated under the laws of Companies Act 1956 and having its Principal place of business at .....(*Address of Lead Partner*) ..... and Registered Office at .....(*Registered address of Lead Partner*) ..... and M/s ..... (*Name of Other Partner*) ..... (the Partner of JOINT VENTURE(JV)), a company incorporated under the laws of Companies Act 1956/2013 (with amendment from time to time) and having its Principal place of business at .....(*Address of Other Partner*)

..... and Registered Office at .....(*Registered address of Other Partner*) ..... (hereinafter called "the Contractor" and also referred to as "Joint Venture(JV)"/the 'JOINT VENTURE(JV)')  
*(Applicable only in case of Joint Venture(JV))*

WHEREAS the Employer desires to engage the Contractor to design, manufacture, test, deliver, install, commission and complete certain Facilities, viz. *[ insert the name of the Package along with ]* ..... ("the Facilities") as detailed in the Contract Document, and the Contractor, in accordance with the mode of contracting specified therein, has agreed to such engagement upon and subject to the terms and conditions appearing in this Contract Agreement Part II for Supply of Installation Services and in Contract Agreement Part I for Supply of Plant for the Facilities, the two parts read together, jointly and in conjunction, constituting the Contract. and the aggregate of the Contract Price for Contract Part I and the Contract Price for Contract Part II constituting the Contract Price for the Contract.

WHERE, the Employer, under this Contract Agreement Part II, desires to engage the Contractor for the supply of Installation Services for providing/ supplying all Installation Services (excluding the incidental services included in Contract Part I), interalia, unloading and handling of Plant, all labor, Contractor's equipment, temporary works, materials, consumables, design and preparation of layout, engineering drawings, and all matters and things of whatsoever nature, including testing, pre-commissioning, guarantee tests and commissioning, the provision of as-built drawings, operations and maintenance manuals, training, etc., applicable and necessary for the proper execution of the installation and other services, at final destination (Site/ Project Site), related to and incidental to successful installation of the Plant supplied under the Contract Part I, for the complete execution of the ..... (*insert name of Package along with name of the Project*) ....., and the scope of work is briefly described below:

[.....insert brief scope of work.....]

NOW IT IS HEREBY AGREED as follows:

#### Article 1. Contract Documents

##### 1.1 Contract Documents (Reference GCC Clause 2)

The following documents shall constitute the Contract between the Employer and the Contractor, and each shall be read and construed as an integral part of the Contract:

#### VOLUME – A

1. This Contract Agreement and the Appendices thereto.

2. Notification of Award Ref. No. ....../NOA-II/02 dated DD/MM/YYYY.

#### VOLUME – B

3. Documents comprising of the following:
  - Conditions of Contract and Contract Forms (Part 3 of Bidding Documents)
    - Conditions of Contract including Special Conditions of Contract (SCC) and General Conditions of Contract (GCC); (Section 7 of Bidding Documents)
    - Contract Forms (Section 8 of Bidding Documents)
  - Employers' Requirements (Part 2 of Bidding Documents)
    - Employer's Requirements (Section 6 of Bidding Document)
  - Bidding Procedures and Requirements (Part 1 of Bidding Documents)
    - Request for Bids Notice (Section 1 of Bidding Documents)
    - Eligibility and Qualification Requirements (Section 2 of Bidding Documents)
    - Instruction to Bidders and Bid Data Sheets (Section 3 of Bidding Documents)

#### VOLUME – C

4. Bid Submitted by the Contractor.

(Only relevant extracts are attached herewith for easy reference. Should the circumstances warrant, the original Bid along with the enclosures thereof, shall be referred to.).

#### 1.2 Order of Precedence (Reference GCC Clause 3)

In the event of any ambiguity or conflict between the Contract Documents listed above, the order of precedence shall be the order in which the Contract Documents are listed in Article 1.1 (Contract Documents) above.

#### 1.3 Definitions (Reference GCC Clause 1)



Capitalized words and phrases used herein shall have the same meanings as are ascribed to them in the General Conditions of Contract/Special Conditions of Contract.

## Article 2. Contract Price and Terms of Payment

### 2.1 Contract Price (Reference GCC Clause 11) for Contract Part II

The Employer hereby agrees to pay to the Contractor the Contract Price for Contract Part II in consideration of the performance by the Contractor of its obligations hereunder. The Contract Price for Contract Part II shall be the aggregate of ..... (*amount in words*) ..... (*.....(amount in figures).....*), or such other sums as may be determined in accordance with the terms and conditions of the Contract. The break-up of the Contract Price for Contract Part II is as under:

Sl. No.	Price Component	Amount
1.	Installation Services	
2.	Training Charges (if required)	Not Applicable
Total for Supply of Installation Services Contract		

The detailed break-up of Contract Price for Contract Part I is given in the relevant Appendices hereto.

### 2.2 Terms of Payment (Reference GCC Clause 12)

The terms and procedures of payment according to which the Employer will reimburse the Contractor are given in Appendix 1 (Terms and Procedures of Payment) hereto.

## Article 3. Effective Date for Determining Time for Completion

### 3.1 Effective Date (Reference GCC Clause 1)

The Effective Date from which the Time for Completion of the Facilities shall be counted and determined is the date of the Notification of Award i.e., .....

## Article 4. Appendices

The Appendices listed in the List of Appendices, as mentioned below, shall be deemed to form an integral part of this Contract Agreement Part II and the Contract.

Reference in this Contract Agreement Part II and the Contract to any Appendix shall mean and include the Appendices attached hereto, and this Contract Agreement Part II and the Contract shall be read and construed accordingly.

#### List of Appendices

Appendix 1	Terms and Procedures of Payment
Appendix 2	Price Adjustment
Appendix 3	Insurance Requirements
Appendix 4	Time Schedule
Appendix 5	List of Approved Subcontractors
Appendix 6	Scope of Works and Supply by the Employer
Appendix 7	List of Document for Approval or Review
Appendix 8	Guarantees, Liquidated Damages for Non-Performance
Appendix 9	Price Schedules indicating Price Breakdown of Contract Price for Contract Part II for Supply of Installation Services
Appendix 11	Integrity Pact

#### Article 5.

The Contract Agreement Part I No. .... has also been made on the ..... day of ..... 20...., between the Employer and the Contractor for the Supply of Plant (hereinafter referred to as the “Contract Part I”) for the supply of Plant on FOR {final place of destination (Site/ Project Site)} basis interalia including design, engineering, manufacture, testing, transportation, insurance etc. and other services, incidental thereto, required for the complete execution of the ..... (*insert name of Package along with name of the Project*) ....., and the scope of work is briefly described below:

[.....insert brief scope of work .....] ]

Notwithstanding the award of work for Completion of the Facilities under the Contract in two separate parts in the aforesaid manner, the Contractor shall be overall responsible to ensure the execution of both the parts of the Contract to achieve successful completion and taking over of the Facilities by the Employer as per the requirements stipulated in the Contract. It is expressly understood and agreed by the Contractor that any default or breach under the ‘Contract Part I’ shall automatically be deemed as a default or breach of this ‘Contract Part II’ also and vice-versa and any such breach or occurrence or default giving the Employer a right

to terminate the ‘Contract Part I’ either in full or in part, and/or recover damages there under the Contract Part I, shall give the Employer an absolute right to terminate this Contract Part I at the Contractor’s risk, cost and responsibility, either in full or in part and /or recover damages under this ‘Contract Part II’ as well. However, such breach or default or occurrence in the ‘Contract Part I’ shall not automatically relieve the Contractor of any of its responsibility/ obligations under this ‘Contract Part I’. It is also expressly understood and agreed by the Contractor that the Plant/equipment /goods/ materials supplied by the Contractor under the ‘Contract Part I’ when erected, installed and commissioned by the Contractor under this ‘Contract part II’ shall give satisfactory performance in accordance with the provisions of the Contract.

IN WITNESS WHEREOF the Employer and the Contractor have caused this Agreement to be duly executed by their duly authorized representatives the day and year first above written.

Signed by for and  
on behalf of the Employer

Signed by for and  
on behalf of the Contractor

.....  
Signature

.....  
Signature

.....  
Title

.....  
Title

in the presence of

in the presence of

*(Separate Contract Agreements shall be executed by the Employer and the Contractor in accordance with the mode of contracting stipulated at ITB, Section 3 of bidding documents. The forms of Contract under both Alternative i.e., a & b shall be used).*



## Appendix-1: TERMS AND PROCEDURES OF PAYMENT

I. “Billable Items” are worked out and attached to Price Schedule. Items otherwise required for completion of work but not listed in the Price Schedule shall also be in the scope of the Contractor. The costs of such “Non- billable Items” is deemed to be included in the quoted price of “Billable Items” by the bidder in the Price Schedule. The payment shall be made on billable item wise basis only as indicated in Price Schedule.

II. Valid Contract Performance Security to furnished by the Contractor as per the Contract and accepted by the Employer, shall be a condition precedent for release of the advance and progressive payment. Further, for release of any advance payment, requisite securities including Advance Payment Guarantee, as the case may be, to be furnished by the Contractor as specified in the Contract and accepted by the Employer, shall also be a condition precedent. In case, the duration of contract gets extended then the Contractor shall furnish the revised Performance Bank Guarantee equal to 10% of the contract value and valid till 30 days beyond the warranty period as per the new contract timelines. The revised Bank Guarantee shall be submitted by the Contractor within 28 days from the date of approval of time extension by the Employer.

III. The interest rate on advance payment shall be Marginal Cost of Funds Based Lending Rate (MCLR) for one year of the State Bank of India, prevailing on the date of advance payment to the Contractor. The interest accrued on interest bearing advance shall be adjusted first before releasing any payment. The interest rate shall be calculated on the daily progressive balances outstanding as on the date of recovery/adjustment i.e. on daily rest basis.

IV. Unmeasured ad-hoc payment: The employer, at his discretion in exigencies, to ensure liquidity of funds with the Contractor may accept un-measured ad-hoc bill of the Contractor. In this method, following methodology shall be adopted:

a. Submission of certificate on measurement book by Project Manager that materials under consideration have been erected, tested and commissioned as per technical specification, scope of work & approved drawings.

b. Quantum and completion of works is certified by Project Manager jointly with Contractor and eligible amount of such works are computed as per approved payment terms.

The payment shall be made to the contractor as per following:

<b>Sr. No.</b>	<b>Milestone</b>	<b>Name of the activity</b>	<b>Timeline</b>	<b>Payment % of Contract Price</b>
1		Resource Mobilization	2 Weeks from LOI/LOA	
2		As- Is study and preparation of To-be Documents comprising of HLDD, LLDD, IT Infra Landscape with H/W & N/W architecture and BOQ. This timeline is inclusive of WBSEDCL internal timeline for approval process of Min. 15 Days. IA needs to submit the required “As-Is” & “To-be” reports accordingly.	8 Weeks from LOI/LOA	
<b>Supply milestone</b>				
3A	M1	Supply of Network Hardware/Software.	12 Weeks from LOI/LOA	10
3B		Supply of Backup Device/ Software/License	15 Weeks from LOI/LOA	10
3C	M2	Supply of Virtualisation Software, Server, Storage hardware.	20 Weeks from LOI/LOA	10
<b>Service: Installation/Implementation, integration, migration, UAT,Go-Live and stabilisation</b>				
4A		Installation Network Hardware/Software	26 Weeks from LOI/LOA	
4B		Installation and Implementation of Backup Solution	30 weeks from LOI/LOA	
4C	M3	Installation and Implementation of Virtualisation Software, Server, Storage hardware.	38 weeks from LOI/LOA	
5	M4	Integration and Migration Services	50 Weeks from LOI/LOA	10
6	M5	User Acceptance Test and Go Live	52 Weeks from LOI/LOA	10

NB: Buy back price will be adjusted with the payments of supply milestone 3A/3B/3C

## Appendix-2 :PRICE ADJUSTMENT

The prices for execution of the entire works covered under the scope of this work shall be quoted by the Bidder in the manner specified, in the BPS. The Ex-works price component, less advance will be subject to price adjustment, only for equipment/materials/items of work specifically stated under clause 1.0 below, (for which the bidder shall quote a base price), based on separate formulae as per price adjustment provisions given herein. However, it shall be noted that the Price Adjustment clause will be effective from the contract signing date. The Employer shall ensure that all the Price Adjustment would be governed as per the approved L-2 schedule signed by Employer and Contractor, which would be included in the contract.

Prices for Ex-works price component for all other equipment/items except specified at Clause 1.0 below, Charges for Erection, Inland Freight & Insurance etc. shall be FIRM and no price adjustment shall be applicable for these components for the entire duration of the Contract.

No price adjustment shall be applicable on the portion of the Contract Price payable to the Contractor as advance payment. However, if a Contractor opts for no advance then Price Adjustment would be applicable on 100% contract value.

### 1.0 Materials and Labour portion:

#### 1.0.1 For ACSR Conductor

The price quoted/confirmed for Aluminum Conductor is based on the input cost of raw materials as on the date of quotation. It is deemed to be related to the prices of the raw materials, as specified in the price variation clauses mentioned below. In case of any variation in these prices, the prices payable shall be subject to adjustment up or down in accordance with the following formula:

For Excise duty units:

$$P = P_0 + WA (AL - AL_0) + WF (FE - FE_0)$$

For Excise duty exempted units:

$$P = P_0 + WA (AL_e - AL_{0e}) + WF (FE_e - FE_{0e})$$

Wherein,

P = Ex-works price payable in Rs. Per km as adjusted in accordance with the price variation clause

P<sub>0</sub> = Ex-works price quoted/confirmed in Rs. Per km.

WA = Weight of Aluminium in ACSR conductor in MT per km. (As per IS: 398)

WF = Weight of Steel content in the ACSR conductor in MT per km. (As per IS: 398)

AL = Price of EC Grade Aluminium Ingot/Rod (as per contract) exclusive of excise duty in Rs./MT for the conductor. This price is applicable prevailing as on 30 days prior to the date of delivery.



~~$A_{1e}$  = Price of EC Grade Aluminium Ingot/Rod (as per contract) inclusive of excise duty in Rs./MT for the conductor. This price is applicable prevailing as on 30 days prior to the date of tender delivery.~~

~~$A_{1o}$  = Price of EC Grade Aluminium Ingot/Rod (as per contract) exclusive of excise duty in Rs./MT for the conductor. This price is applicable prevailing as on 30 days prior to the date of tender opening.~~

~~$A_{1oe}$  = Price of EC Grade Aluminium Ingot/Rod (as per contract) inclusive of excise duty in Rs./MT for the conductor. This price is applicable prevailing as on 30 days prior to the date of tender opening.~~

~~$FE$  = Price (exclusive of excise duty) of high tensile galvanized steel wire in Rs./MT of appropriate size. This price is applicable prevailing as on 30 days prior to the date of delivery.~~

~~$FE_e$  = Price (exclusive of excise duty) of high tensile galvanized steel wire in Rs./MT of appropriate size. This price is applicable prevailing as on 30 days prior to the date of delivery.~~

~~$FE_o$  = Price (exclusive of excise duty) of high tensile galvanized steel wire in Rs./MT of appropriate size. This price is applicable prevailing as on 30 days prior to the date of tender opening.~~

~~$FE_{oe}$  = Price (exclusive of excise duty) of high tensile galvanized steel wire in Rs./MT of appropriate size. This price is applicable prevailing as on 30 days prior to the date of tender opening.~~

*Note : In case of any clarifications in the above formula kindly refer the IEEMA price variation formula for ACSR conductors given in circular IEEMA/PVC/CONDUCTOR/2012 effective from 1<sup>st</sup> April 2012, In case of any discrepancies the IEEMA circular mentioned shall prevail.*

#### ~~1.0.2 For Station/ Power Transformer~~

~~The price adjustment on the Ex works price component, less advance, of Transformers shall be as follows:~~

##### ~~1.0.2.1 The price variation clause for 'Power Transformers'~~

~~The price payable shall be subject to adjustment, up or down in accordance with the following formula:~~

$$~~P = 0.01 \times P_o ( 6 + 32X (C / C_o) + 27 X(ES / ES_o) + 12X (IS / IS_o) + 4X(IM / IM_o) + 9X(TO/TO_o) + 10X(W/W_o) )~~$$

~~Wherein,~~

~~P = Price payable as adjusted in accordance with the above formula.~~

~~P<sub>0</sub> = Price quoted / confirmed.~~

~~C<sub>0</sub> = Price of CC copper rods (as published by IEEMA) This price is applicable for the month, one month prior to the date of tendering.~~

~~E<sub>0</sub> = Price of CRGO Electrical steel lamination (as published by IEEMA) This price is applicable for the month, one month prior to the date of tendering.~~

~~I<sub>0</sub> = Average price of steel Plates 10 mm thick (as published by IEEMA) This price is as applicable for the month, one month prior to the date of tendering.~~

~~I<sub>M0</sub> = Price of Insulating Material (as published by IEEMA) This price is as applicable for the month, one month prior to the date of tendering.~~

~~T<sub>O0</sub> = Price of Transformer oil (as published by IEEMA) This price is as applicable for the month, one month prior to the date of tendering.~~

~~W<sub>0</sub> = All India average consumer price index number for industrial workers, as published by the labour bureau, Ministry of Labour, Govt. of India (Base: 2001 = 100) This index number is applicable for the month, three months prior to the date of tendering.~~

~~C = Price of CC copper rods (as published by IEEMA) This price is applicable for the month, two months prior to the date of delivery.~~

~~E<sub>S</sub> = Price of CRGO Electrical steel lamination (as published by IEEMA) This price is applicable for the month, two months prior to the date of delivery.~~

~~I<sub>S</sub> = Average price of Steel Plates 10 mm thick (as published by IEEMA) This price is as applicable for the month, one month prior to the date of delivery.~~

~~I<sub>M</sub> = Price of Insulating Material (as published by IEEMA) This price is as applicable for the month, two months prior to the date of delivery.~~

~~T<sub>O</sub> = Price of Transformer oil (as published by IEEMA) This price is as applicable for the month, one month prior to the date of delivery.~~

~~W = All India average consumer price index number for industrial workers, as published by the labour bureau, Ministry of Labour, Govt. of India (Base: 2001 = 100) This index number is as applicable for the month, three months prior to the date of delivery.~~

*Note : In case of any clarifications in the above formula kindly refer the IEEMA price variation formula given in circular IEEMA/PVC/PWR TRF\_upto\_400 KV/2021 effective from 1<sup>st</sup> September 2021, In case of any discrepancies the IEEMA circular mentioned shall prevail.*

### ~~1.0.3 Station / Distribution Transformer (Aluminum/Copper wound)~~

~~The price adjustment on the Ex works price component, less advance, of Transformers shall be as follows:~~

1.0.3.1 The price variation clause for Aluminium wound distribution transformers (Single & Three phase of ratings upto and including 2,500kVA and voltage upto 33kV) complete with all accessories and components.

The price payable shall be subject to adjustment, up or down in accordance with the following formula:

$$P = 0.01 \times P_o ( 8 + 22X (AL / AL_o) + 36X(ES / ES_o) + 12X(IS / IS_o) + 5X(IM / IM_o) + 10 X(TO/TO_o) + 7X(W/W_o) )$$

Wherein,

P = Price payable as adjusted in accordance with the above formula.

P<sub>o</sub> = Price quoted / confirmed.

AL<sub>o</sub> = LME CSP Average of Aluminium (as published by IEEMA) This price as applicable for the month, one month prior to the date of tendering.

ES<sub>o</sub> = Price of CRGO Electrical steel lamination (as published by IEEMA) This price as applicable for the month, one month prior to the date of tendering.

IS<sub>o</sub> = Price of the HR coil of 3.15 mm thickness (as published by IEEMA) This price is as applicable for the month, one month prior to the date of tendering.

IM<sub>o</sub> = Price of Insulating Material (as published by IEEMA) This price is as applicable for the month, one month prior to the date of tendering.

TO<sub>o</sub> = Price of Transformer oil (as published by IEEMA) This price is as applicable for the month, one month prior to the date of tendering.

W<sub>o</sub> = All India average consumer price index number for industrial workers, as published by the labour bureau, Ministry of Labour, Govt. of India (Base: 2016 = 100) This index number is as applicable for the month, three months prior to the date of tendering.

AL = LME CSP Average of Aluminium (as published by IEEMA) This price as applicable for the month, one month prior to the date of delivery.

ES = Price of CRGO Electrical steel lamination (as published by IEEMA) This price as applicable for the month, one month prior to the date of delivery.

IS = Price of the HR coil of 3.15 mm thickness (as published by IEEMA) This price is as applicable for the month, one month prior to the date of delivery.

IM = Price of Insulating Material (as published by IEEMA) This price is as applicable for the month, one month prior to the date of delivery.

TO = Price of Transformer oil (as published by IEEMA) This price is as applicable for the month, one month prior to the date of delivery.

W = All India average consumer price index number for industrial workers, as published by the labour bureau, Ministry of Labour, Govt. of India (Base: 2001 = 100) This index number is as applicable for the month, three months prior to the date of delivery.

*Note : In case of any clarifications in the above formula kindly refer the IEEMA price variation formula given in circular IEEMA/PVC/DIST\_AL upto 2.5*

*MVA/2021 effective from 1<sup>st</sup> September 2021, In case of any discrepancies the IEEMA circular mentioned shall prevail.*

1.0.3.2 The price variation clause for Copper wound distribution transformers (Single & Three phase of ratings upto and including 2,500kVA and voltage upto 33kV) complete with all accessories and components.

The price payable shall be subject to adjustment, up or down in accordance with the following formula:

$$P = 0.01 \times P_0 \left( 7 + 41 \times \left( \frac{C}{C_0} \right) + 23 \times \left( \frac{ES}{ES_0} \right) + 10 \times \left( \frac{IS}{IS_0} \right) + 5 \times \left( \frac{IM}{IM_0} \right) + 8 \times \left( \frac{TO}{TO_0} \right) + 6 \times \left( \frac{W}{W_0} \right) \right)$$

Wherein,

P = Price payable as adjusted in accordance with the above formula.

P<sub>0</sub> = Price quoted / confirmed.

C<sub>0</sub> = Price of CC copper rods (as published by IEEMA) This price as applicable for the month, one month prior to the date of tendering.

ES<sub>0</sub> = Price of CRGO Electrical steel lamination (as published by IEEMA) This price as applicable for the month, one month prior to the date of tendering.

IS<sub>0</sub> = Price of the HR coil of 3.15 mm thickness (as published by IEEMA) This price is as applicable for the month, one month prior to the date of tendering.

IM<sub>0</sub> = Price of Insulating Material (as published by IEEMA) This price is as applicable for the month, one month prior to the date of tendering.

TO<sub>0</sub> = Price of Transformer oil (as published by IEEMA) This price is as applicable for the month, one month prior to the date of tendering.

W<sub>0</sub> = All India average consumer price index number for industrial workers, as published by the labour bureau, Ministry of Labour, Govt. of India (Base: 2016 = 100) This index number is as applicable for the month, three months prior to the date of tendering.

C = Price of CC copper rods (as published by IEEMA) This price is as applicable for the month, one month prior to the date of delivery.

ES = Price of CRGO Electrical steel lamination (as published by IEEMA) This price is as applicable for the month, one month prior to the date of delivery.

IS = Price of the HR coil of 3.15 mm thickness (as published by IEEMA) This price is as applicable for the month, one month prior to the date of delivery.

IM = Price of Insulating Material (as published by IEEMA) This price is as applicable for the month, one month prior to the date of delivery.

TO = Price of Transformer oil (as published by IEEMA) This price is as applicable for the month, one month prior to the date of delivery.

W = All India average consumer price index number for industrial workers, as published by the labour bureau, Ministry of Labour, Govt. of India (Base: 2016 = 100) This index number is as applicable for the month, three months prior to the date of delivery.

*Note : In case of any clarifications in the above formula kindly refer the IEEMA price variation formula given in circular IEEMA/PVC/DIST\_CU\_upto 2.5 MVA/2021 effective from 1<sup>st</sup> September 2021, In case of any discrepancies the IEEMA circular mentioned shall prevail.*

#### 1.0.4 Cables

The price adjustment on the Ex works price component, less advance, of Cables shall be as follows:

Terms used in price variation formula :

P = Price payable as adjusted in accordance with the appropriate formula (in Rs/km)

P<sub>0</sub> = Price quoted/confirmed (in Rs/km)

##### **Aluminium**

AIF = Variation factor in Aluminium (as published by IEEMA)

AI = Price of EC grade aluminum rods (Properzi rods) (as published by IEEMA).

This price is as applicable on the first working day of the month, one month prior to the date of delivery.

A<sub>0</sub> = Price of EC grade aluminum rods (Properzi rods) (as published by IEEMA).

This price is as applicable on the first working day of the month, one month prior to the date of tendering.

##### **Copper**

CuF = Variation factor for copper

Cu = Price of CC copper rods (as published by IEEMA). This price is as applicable on the first working day of the month, one month prior to the date of delivery.

Cu<sub>0</sub> = Price of CC copper rods (as published by IEEMA). This price is as applicable on the first working day of the month, one month prior to the date of tendering.

##### **PVC Compound Polymer**

PVCc = Price of PVC compound (as published by IEEMA). This price is as applicable on the first working day of the month, one month prior to the date of delivery.

PVCc<sub>0</sub> = Price of PVC compound (as published by IEEMA). This price is as applicable on the first working day of the month, one month prior to the date of tendering.

CCFAI = Variation factor for PVC Compound/ Polymer for aluminum conductor cable (as published by IEEMA)

CCFCu = Variation factor for PVC Compound/ Polymer for copper conductor cable (as published by IEEMA)

##### **XLPE COMPOUND**

Cc = Price of XLPE compound. This price is as applicable on first working day of the month, one month prior to the date of delivery.

~~Ceo = Price of XLPE compound. This price is as applicable on first working day of the month, one month prior to the date of tendering.~~

~~XLFAL = Variation factor for XLPE compound for aluminum conductor cable.~~

~~XLFCU = Variation factor for XLPE compound for Copper Conductor cable.~~

### **Steel**

~~FeF = Variation factor for steel (as published by IEEMA)~~

~~FeW = Variation factor for round wire steel armouring (as published by IEEMA)~~

~~Fe = Price of steel strips / steel wire (as published by IEEMA). This price is as applicable on the first working day of the month, one month prior to the date of delivery.~~

~~Feo = Price of steel strips / steel wire (as published by IEEMA). This price is as applicable on the first working day of the month, one month prior to the date of tendering.~~

~~The prices and indices mentioned above are published by IEEMA vide circular reference IEEMA(PVC)/Cable/ / prevailing as on 1<sup>st</sup> working day of the month i.e., one month prior to the date of tendering.~~

~~Price variation formulae for Power Cables~~

~~A. Aluminium conductor PVC insulated 1.1kV power cables~~

$$P = P_0 + AIF (AL - A_{lo}) + CCFAI (PVCC - PVC_{co}) + FeF (Fe - Fe_0)$$

~~For unarmoured multicore cables (without steel armour); FeF = 0~~

~~B. Copper conductor PVC insulated 1.1kV power cables~~

$$P = P_0 + CuF (Cu - Cu_0) + CCFCu (PVCC - PV_{Cco}) + Fef (Fe - Fe_0) + AIF (Al - A_{lo})$$

~~For steel armoured cables; AIF = 0~~

~~For aluminium armoured cables ; FeF = 0~~

~~For unarmoured cables ; FeF, AIF = 0~~

~~C. Copper conductor PVC insulated 1.1kV control cables~~

$$P = P_0 + CuF (Cu - Cu_0) + CCFCu (CC - C_{co}) + FeF (Fe - Fe_0)$$

~~For unarmoured cables; FeF = 0~~

~~D. Aluminium conductor XLPE insulated 1.1kV power cables~~

$$P = P_0 + AIF (AL - A_{lo}) + XLFAL (CC - C_{co}) + CCFAI (PVCC - PVC_{co}) + FeF (Fe - Fe_0)$$

~~For unarmoured cables; FeF = 0~~

~~E. Copper conductor XLPE insulated 1.1kV power cables~~

$$P = P_0 + CuF (Cu - Cu_0) + XLFCU (CC - C_{co}) + CCFCu (PVCC - PVC_{co}) + FeF (Fe - Fe_0) + AIF (AL - A_{lo})$$

~~For steel armoured cables; AIF = 0~~

~~For aluminium armoured cables ; FeF = 0~~

~~For unarmoured cables ; FeF, AIF = 0~~

~~F. Copper conductor XLPE insulated 1.1kV control cables~~

$$P = P_0 + CuF (Cu - Cu_0) + XLFCU (CC - C_{co}) + CCFCu (PVCC - PVC_{co}) + FeF (Fe - Fe_0)$$

~~For unarmoured cables; FeF = 0~~

G. For Aluminium conductor XLPE insulated 3.3 to 33kV power cables

~~$P = P_0 + AIF (Al - Al_0) + XLFAL (CC - C_{co}) + CCFAl (PVCc - PVC_{co}) + FeF (Fe - Fe_0)$~~

~~For unarmoured multicore cables (without steel armour);  $FeF = 0$~~

H. Copper conductor XLPE insulated 3.3 to 33kV power cables

~~$P = P_0 + CuF (Cu - Cu_0) + XLFCU (CC - C_{co}) + CCFCu (PVCC - PVC_{co}) + FeF (Fe - Fe_0) + AIF (AL - Al_0)$~~

~~For steel armoured cables;  $AIF = 0$~~

~~For aluminium armoured cables;  $FeF = 0$~~

~~For unarmoured cables;  $FeF, AIF = 0$~~

*Note :In case of any clarifications in the above formula kindly refer the IEEMA price variation formula given in circular IEEMA/DIV/CAB/05 dated 24.04.2018 effective from 1<sup>st</sup> November 2017, In case of any discrepancies the IEEMA circular mentioned shall prevail.*

#### 1.0.5 ~~A. Steel Structure~~

~~Steel structure (excluding nuts, bolts) used in fabrication work at various places in Sub Transmission and Distribution network (such as lattice structure used in ST&D network/line, switchyard etc.), which are billable items in the Bill of quantity (BOQ) shall be covered under this head. The price adjustment formula for such structural steel items shall be as mentioned hereinafter.~~

~~The price component of the structural steel for any shipment/ dispatch comprises of a fixed portion (designated as 'F' and the value of which is specified hereunder) and a variable portion linked with the indices for respective materials and labour (description and co-efficient as enumerated below):~~

~~The amount of price adjustment towards variable portion payable/recoverable on each shipment/dispatch shall be computed as under:~~

~~$$EC = EC1 - EC0$$~~

~~EC1 will be computed as follows in any of appropriate manner as applicable (a or b or c):~~

~~a) For structure using both heavy and lighter angles:~~

~~$$EC1 = EC0 * [F + 0.18 * (HA1/HA0) + 0.40 * (LA1/LA0) + 0.16 * (Zn1/Zn0) + 0.11 * (L1/L0)]$$~~

~~b) For structure using only heavy angles:~~

~~$$EC1 = EC0 * [F + 0.58 * (HA1/HA0) + 0.16 * (Zn1/Zn0) + 0.11 * (L1/L0)]$$~~

~~c) For structure using only lighter angles:~~

~~$$EC1 = EC0 * [F + 0.58 * (LA1/LA0) + 0.16 * (Zn1/Zn0) + 0.11 * (L1/L0)]$$~~

~~d) Steel Pole Tower (including Bolts, Nuts & structural component etc.)~~

$$EC1 = EC0 [0.15 + 0.58 * (HA1/HA0) + 0.16 * (Zn1/Zn0) + 0.11 * (L1/L0)] - EC0$$

Where

EC = Adjustment to Ex Works price component payable to Contractor for each shipment/dispatch

EC1 = Adjusted amount of Ex works price component of Contract payable to Contractor for each shipment / dispatch.

EC0 = Ex works price for the respective item of the Contract, Shipment/dispatch wise (quoted price).

F = Fixed portion of the ex-works/FOB component of the Contract Price (F) shall be 0.15.

HA = Price of Heavy angle steel, as published by IEEMA

LA = Price of Lighter angle steel, as published by IEEMA

Zn = Price of electrolytic high grade zinc, as published by IEEMA

L = All India average Consumer Price Index Number for Industrial Workers (base 2001=100) as published/declared by Labour Bureau, Shimla, Government of India and circulated by IEEMA.

For the indices, subscript 'o' refers to indices as on 30 days prior to date set for opening of bids. Subscript '1' refers to indices as of

(a) two months/sixty (60) days prior to the date of shipment/dispatch for labour, and

(b) at the expiry of two third (2/3) period from the date of Notification of Award to the date of shipment/dispatch, for material.

For the purpose of this clause the date of shipment/ dispatch shall mean the Schedule date of shipment/dispatch or actual date of shipment/dispatch, whichever is earlier. The schedule date of shipment/dispatch shall be as identified in line with provisions of Time Schedule in the Contract Agreement.

In case of shipments/ dispatches which are delayed beyond the schedule date of shipment/dispatch for reasons attributable to the Contractor, the price adjustment provision shall not be applicable for the period of time between the schedule date of shipment/dispatch and the actual date of shipment/dispatch.

Note: As per IEEMA Circular No. IEEMA(PVC)/TLT/(R)/02/2007-

- 1) Heavy Steel Angles of size 150mm\*150mm\*12mm as per IS 2062 has been categorized as Heavy Angles (HA).
- 2) Re-rolled steel angles of size 50mm\*50mm\*4 mm Lighter has been categorized as Lighter Angles (LA).
- 3) Input costs for all heavy angles of size above 110m\*110mm are deemed to be related to the price under Sr No.1.
- 4) Input costs for all lighter angles of size below & including 110m\*110mm are deemed to be related to the price under Sr No.2.

**Steel Tubular Poles: PRICE VARIATION CLAUSE FOR POLES:** The price quoted/confirmed is based on the input cost of raw materials/components and



labour cost as on the date of quotation and the same is deemed to be related to prices of raw materials and all India average consumer price index number for industrial workers as specified in the price variation clause given below. In case of any variation in these prices and index numbers, the price payable shall be subject to adjustment, up or down in accordance with the following formula:

(A) Steel Tubular Poles

$$P = P_0 \cdot 100 \left( 7 + 70 \frac{IS_0}{IS} + 13 \frac{Zn_0}{Zn} + 10 \frac{W_0}{W} \right)$$

(B) Polygonal Poles

$$P = P_0 \cdot 100 \left( 9 + 64 \frac{IS_0}{IS} + 13 \frac{Zn_0}{Zn} + 14 \frac{W_0}{W} \right)$$

Wherein,

P = Price payable as adjusted in accordance with the above formula.

P<sub>0</sub> = Price quoted/confirmed.

IS<sub>0</sub> = Price of HR Coil of 3.15 mm thickness (refer notes) This price is as applicable for the month, ONE month prior to the date of tendering.

Zn<sub>0</sub> = Price of Electrolytic high grade zinc (refer notes) This price is as applicable on the 1st working day of the month, ONE month prior to the date of tendering.

W<sub>0</sub> = All India average consumer price index number for industrial workers, as published by the Labour Bureau, Ministry of Labour, Govt. of India (Base: 2016 = 100) (Refer notes)

This index number is as applicable for the month, THREE months prior to the date of tendering.

For example, if date of tendering falls in May 2022, the applicable prices of HR Coil (IS<sub>0</sub>) should be for the month March 2022, Zinc (Zn<sub>0</sub>) should be for the month April 2022 and all India average consumer price index number (W<sub>0</sub>) should be for the month of February 2022.

The above prices and indices are as published by IEEMA vide circular reference number IEEMA (PVC)/TLT-2014 (R-1)/\_/\_/ ONE month prior to the date of tendering.

IS = Price of HR Coil of 3.15 mm thickness (refer notes) This price is as applicable for the month, FOUR month prior to the date of delivery.

Zn = Price of Electrolytic high grade zinc (refer notes) This price is as applicable on the 1st working day of the month, ONE month prior to the date of delivery.

W = All India average consumer price index number for industrial workers, as published by the Labour Bureau, Ministry of Labour, Govt. of India (Base: 2016 = 100) (Refer notes) This index number is as applicable on the first working day of the month, THREE months prior to the date of delivery.

For example, if date of delivery falls in December 2022, the applicable prices of HR Coil (IS) should be for August 2022 and Zinc (Zn) should be for the month November 2022 and all India average consumer price index number

~~(W) should be for the month of September 2022.~~

~~The date of delivery is the date on which Poles are notified as being ready for inspection/dispatch (in the absence of such notification, the date of manufacturer's dispatch note is to be considered as the date of delivery) or the contracted delivery date (including any agreed extension thereto), whichever is earlier.~~

~~Notes:~~

~~(a) All prices of raw materials are exclusive of GST and any other central, state or local taxes etc.~~

~~(b) The details of prices are as under:~~

~~1. Price of steel is the average retail price of HR Coil 3.15 mm thickness as published by Joint Plant Committee (JPC) in Rs./MT.~~

~~2. The price of Electrolytic high grade zinc (in Rs/MT) is ex-works price as quoted by a primary producer.~~

~~(C) Note : In case of any clarifications in the above formula kindly refer the IEEMA price variation formula given in circular 10/PVC/T & D Project/05 effective from 1<sup>st</sup> April 2022, In case of any discrepancies the IEEMA circular mentioned shall prevail.~~

#### ~~1.0.6 **66/11 KV & 33/11 KV Switchgear (indoor/outdoor) including 66/33/11 KV Circuit Breakers and Isolators:**~~

~~The Contract Price shall be subject to price adjustment during performance of the Contract to reflect changes in the cost of labour and material components in accordance with the provisions described below.~~

~~The Ex Works price of 66/11 KV & 33/11 KV Switchgear (Indoor/Outdoor), Circuit Breakers, and Isolators excluding Mandatory Spares and Type Tests Charges (if any) will be subject to Price adjustment. The price adjustment formula for the components of the Contract Price, as mentioned above shall be as stipulated hereinafter.~~

~~The price component of the equipment for any shipment/ dispatch comprises of a fixed portion (designated as 'F' and the value of which is specified hereunder) and a variable portion linked with the indices for various materials and labour (description and co-efficient as enumerated below).~~

~~The amount of price adjustment towards variable portion payable/recoverable on each shipment/dispatch shall be computed as under:~~

$$~~P = 0.01 \times P_0 (20 + 28 (IS / IS_0) + 26 (C / C_0) + 4 (AL / AL_0) + 9 (In / In_0) + 13 (W / W_0))~~$$

~~Wherein,~~

~~P = Price payable as adjusted in accordance with the above formula~~

~~Po = Price quoted/confirmed~~

~~ISo = Wholesale price index number for 'Manufacture of Basic Metals'(Base: 2011-12 = 100)(as published by IEEMA). This price index number for the month, Three month prior to the date of tendering~~

~~Co = Average LME settlement price of copper wire bars (as published by IEEMA). This price is applicable for the month, One month prior to the date of tendering~~

~~Alo = Price of busbar grade aluminum(as published by IEEMA). This price is applicable on the 1<sup>st</sup> working day of the month, One month prior to the date of tendering~~

~~Ino = Price of epoxy resin for indoor circuit breakers and switch gear(as published by IEEMA). This price is applicable on the 1<sup>st</sup> working day of the month, One month prior to the date of tendering~~

~~Or wholesale price index of insulator for outdoor circuit breakers (VBF and SDB) (as published by IEEMA). This index number is as applicable for the month, Three month prior to the date of tendering~~

~~Wo = All India average consumer price index number for industrial workers, as published by the Labour bureau, Ministry of Labour, Government of India (Base : 2001 = 100)~~

~~This index number is as applicable for the month, Four month prior to the date of tendering. (as published by IEEMA)~~

~~ISo = Wholesale price index number for 'Manufacture of Basic Metals'(Base: 2011-12 = 100)(as published by IEEMA). This price index number for the month, Three month prior to the date of tendering~~

~~Co = Average LME settlement price of copper wire bars(as published by IEEMA). This price is applicable for the month, One month prior to the date of tendering~~

~~Alo = Price of busbar grade aluminum(as published by IEEMA). This price is applicable on the 1<sup>st</sup> working day of the month, One month prior to the date of tendering~~

~~Ino = Price of epoxy resin for indoor circuit breakers and switch gear(as published by IEEMA). This price is applicable on the 1<sup>st</sup> working day of the month, One month prior to the date of tendering~~

~~Or wholesale price index of insulator for outdoor circuit breakers (VBF and SDB) (as published by IEEMA). This index number is as applicable for the month, Three month prior to the date of tendering~~

~~Wo = All India average consumer price index number for industrial workers, as published by the Labour bureau, Ministry of Labour, Government of India (Base : 2001 = 100)(as published by IEEMA). This index number is as applicable for the month, Four month prior to the date of tendering~~

~~Note :In case of any clarifications in the above formula kindly refer the IEEMA price variation formula given in circular IEEMA/PVC/MVSWGR/2019 (R-2)effective from 1<sup>st</sup> January 2019, In case of any discrepancies the IEEMA circular mentioned shall prevail.~~

#### ~~1.0.7 Aerial Bunched Cables~~

~~The price payable shall be subject to adjustment up or down in accordance with the formulae provided in this document.~~

~~Terms used in price variation formulae:~~

~~P = Price payable as adjusted in accordance with above appropriate formula (in Rs/Km)~~

~~Po = Price quoted/confirmed (in Rs/Km)~~

~~n = No. of phase conductor~~

~~ALUMINIUM~~

~~Alph= Aluminium factor for phase conductor (as published by IEEMA)~~

~~Alm= Aluminium factor for messenger conductor (as published by IEEMA)~~

~~Alsl= Aluminium factor for street light conductor (as published by IEEMA)~~

~~Aln= Aluminium factor for neutral conductor (as published by IEEMA)~~

~~AI = Price of LME average Cash SELLER Settlement price of Primary Aluminium in US\$ per MT as published by London Metal Bulletin (LME) including Premium for Aluminium Ingot in US\$ per MT converted in Rs./MT~~

~~This price is as applicable of first working day of the month, one month prior to the date of delivery.~~

~~Alo= Price of LME average Cash SELLER Settlement price of Primary Aluminium in US\$ per MT as published by London Metal Bulletin (LME) including Premium for Aluminium Ingot in US\$ per MT converted in Rs./MT~~

~~This price is as applicable on first working day of the month, one month prior to the date of tendering.~~

~~**XLPE COMPOUND**~~

~~CCFAlph = XLPE factor for phase conductor (For LV AB Cables) (as published by IEEMA)~~

~~CCF1Alph= XLPE factor for phase conductor (For MV\_HV AB Cables) (as published by IEEMA)~~

~~CCFAlm= XLPE factor for messenger conductor (as published by IEEMA)~~

~~CCFAIs= XLPE factor for street light conductor (as published by IEEMA)~~

~~CCFAln= XLPE factor for neutral conductor (as published by IEEMA)~~

~~Cc = Price of LV/HV XLPE Compound in Rs/MT of a representative grade applicable for LV /HV Aerial~~

~~Bunch Cables respectively; as quoted by supplier/s. (as published by IEEMA)~~

~~This price is as applicable of first working day of the month, one month prior to the date of delivery~~

~~Cco = Price of LV/HV XLPE Compound in Rs/MT of a representative grade applicable for LV /HV Aerial~~

~~Bunch Cables respectively; as quoted by supplier/s.~~

~~This price is as applicable of first working day of the month, one month prior to the date of tendering~~

~~PVC/PE Compound~~

~~CCF2Alph= PVC/ PE factor for phase conductor (For MV\_HV AB Cables)~~

~~PVCc price of PVC compound (equivalent to CW-22 grade) in Rs/MT; as quoted by supplier/s.~~

~~This price is as applicable on first working day of the month, one month prior to the date of delivery~~

~~PVCco Price of PVC compound (Equivalent to CW-22 Grade) in Rs/MT; as quoted by supplier/s.~~

~~This price is as applicable on first working day of the month, one month prior to the date of tendering Copper~~

~~CuFtph= Cu tape factor for phase conductor~~

~~CU = The LME price of Copper Wire Bars (in Rs./MT) is the LME average settlement price of Copper~~

~~Wire Bars converted into Indian Rupees (INR), with average exchange rate of the month. This price is the landed cost, inclusive of applicable customs duty only.~~

~~This price is as applicable of first working day of the month, one month prior to the date of delivery.~~

~~CU0 = The LME price of Copper Wire Bars (in Rs./MT) is the LME average settlement price of Copper~~

~~Wire Bars converted into Indian Rupees (INR), with average exchange rate of the month. This price is the landed cost, inclusive of applicable customs duty only.~~

~~This price is as applicable of first working day of the month, one month prior to the date of tendering.~~

The above prices and indices are as published by IEEMA vide Circular reference IEEMA(PVC)/CABLE(R-1)/-/- prevailing as on 1st working day of the month i.e. one month prior to the date of tendering.

### **Price variation formulae for 'LV & HV Aerial Bunch Cables'**

#### **1. LV Aerial Bunched Cables with Aluminium Conductor, XLPE Insulated and Aluminium Magnesium-Silicon Alloy Messenger Conductor**

$$P = P_0 + \text{Alph} * n * (\text{Al} - \text{Al}_0) + \text{Alm}(\text{Al} - \text{Al}_0) + \text{Alsl}(\text{Al} - \text{Al}_0) + \text{Aln}(\text{Al} - \text{Al}_0) + \text{CCFAlph} * n * (\text{CC} - \text{CC}_0) + \text{CFAlm}(\text{CC} - \text{CC}_0) + \text{CCFAlsl} * n * (\text{CC} - \text{CC}_0) + \text{CCFAln}(\text{CC} - \text{CC}_0)$$

In case messenger is bare; XLPE factor CCFAlm=0

#### **2. HV Aerial Bunched Cables with Aluminium Conductor, Conductor screened, XLPE Insulated, insulation screened followed by copper tape and over all PVC/PE sheathe cores twisted around Bare Aluminium Magnesium-Silicon Alloy Messenger Conductor**

$$P = P_0 + \text{Alph} * n * (\text{Al} - \text{Al}_0) + \text{Alm}(\text{Al} - \text{Al}_0) + \text{CUFtph} * n * (\text{Cu} - \text{Cu}_0) + \text{CCF1Alph} * n * (\text{CC} - \text{CC}_0) + \text{CCF2Alph} * n * (\text{PVCe} - \text{PVCe}_0) + \text{CCFAlm} * n * (\text{CC} - \text{CC}_0)$$

*Note In case of any clarifications in the above formula kindly refer the IEEMA price variation formula given in circular IEEMA(PVC)/AB-CABLE/2017 effective from 1<sup>st</sup> November 2017, In case of any discrepancies the IEEMA circular mentioned shall prevail.*

The PV will be applicable against the materials as specified above.

1.0.8 The Employer shall use the recent formula/ revisions published by IEEMA to calculate the Price adjustment on supply of plants and facilities.

1.0.9 The price adjustment amount towards the price components of materials shall be as per the price variation formulas mentioned in para 1.0.1 to 1.0.8 without any ceiling.

1.0.10 For the purpose of price adjustment for Ex-works price component, the date of shipment for goods shall mean the scheduled date of shipment or actual date of shipment, whichever is earlier. Scheduled date of shipment will be ex-works date of dispatch, governed by the approved PERT Chart as per Appendix 4 Time Schedule.

1.0.11 No price increase shall be allowed beyond the original delivery dates unless specifically stated in the Time Extension letter, if any, issued by the Employer. The Employer will, however, be entitled to any decrease in the Contract price which may be caused due to lower price adjustment amount in case of delivery beyond the original delivery dates. In such event where the time extension is agreed by the

Employer, a revised L2 schedule is to be released by the Employer for the extended period in which price variation would also be allowed.

- 1.0.12 In case of non-publication of applicable indices on a particular date, which happens to be the applicable date for price adjustment purposes, the published indices prevailing immediately prior to the particular date shall be applicable.
- 1.0.13 If the price adjustment amount works out to be positive, the same is payable to the Contractor by the Employer and if it works out to be negative, the same is to be recovered by the Employer from the Contractor without any ceiling.
- 1.0.14 The Contractor shall promptly submit the price adjustment invoices for the supplies made and works executed at site, positively within three (3) months from the date of shipment/work done whether it is positive or negative.
- 1.0.15 Bids shall conform to the price adjustment provisions detailed above. Bids specifying prices for items on variable basis run the risk of rejection. A bid submitted on a fixed price basis will not be rejected but the price adjustment will be treated as zero.
- 1.0.16 In case of extension of the project beyond the scheduled date of completion, the price adjustment shall remain in effect till the time of scheduled completion, however for the period beyond the scheduled date of completion for which the Contractor is liable to pay liquidated damages to the employer, the price adjustment shall not be applicable.

### Appendix-3 : INSURANCE REQUIREMENTS

#### A) Insurances to be taken out by the Contractor

In accordance with the provisions of GCC Clause 34, the Contractor shall at its expense take out and maintain in effect, or cause to be taken out and maintained in effect, during the performance of the Contract, the insurances set forth below in the sums and with the deductibles and other conditions specified. The identity of the insurers and the form of the policies shall be subject to the approval of the Employer, such approval not to be unreasonably withheld. The inability of the insurers to provide insurance cover in the sums and with the deductibles and other conditions as set forth below, shall not absolve the Contractor of his risks and liabilities under the provisions of GCC Clause 34. However, in such a case the Contractor shall be required to furnish to the Employer documentary evidence from the insurer in support of the insurer's inability as aforesaid.

#### (a) Marine Cargo Policy/Transit Insurance Policy:

##### (I) Transit Insurance Policy for indigenous equipment

Similarly, Transit Insurance Policy shall be taken wherein only inland transit is involved for the movement of Plant and Equipment supplied from within India. The policy shall cover movement of Plant and Equipment from the manufacturer's works to the project's warehouse at final destination site. Inland Transit Clause(ITC) 'A' along with war & Strike Riots & Civil Commotion (SRCC) extension cover shall be taken.

Amount	Deductible Limits	Parties insured	From	To
120% of Ex-work Price of all the Plant and Equipment to be supplied from within India plus Excise Duty and Sales Tax/ GST etc., if additionally payable.	Nil	Contractor & Employer	Mfrs warehouse	Project's warehouse store at final destination

- (II) If during the execution of Contract, the Employer requests the Contractor to take any other add-on cover(s)/ supplementary cover(s) in aforesaid insurance, in such a case, the Contractor shall promptly take such add-on cover(s)/ supplementary cover(s) and the charges towards such premium for such add-on cover(s)/ supplementary cover(s) shall be reimbursed to the Contractor on submission documentary evidence of payment to the Insurance company. Therefore, charges towards premium for such add-on cover(s)/ supplementary cover(s) are not included in the Contract Price.



- (III) The Contractor shall take the policy in the joint names of Employer and the Contractor. The policy shall indicate the Employer as the beneficiary. However, if the Contractor is having an open policy for its line of business, it should obtain an endorsement of the open cover policy from the insurance company indicating that the dispatches against this Contract are duly covered under its open policy and include the name of the Employer as jointly Insured in the endorsements to the open policy.

**(b) Erection All Risk Policy/Contractor All Risk Policy:**

- (I) The policy should cover all physical loss or damage to the facility at site during storage, erection and commissioning covering all the perils as provided in the policy as a basic cover and the add on covers as mentioned at Sl. No. (III) below.

Amount	Deductible limits	Parties insured	From	To
105% of Ex-work Price of all the Plant and Equipment to be supplied from within India plus Excise Duty and Sales Tax/ GST etc., if additionally payable. and 100% of erection price component	Nil	Contractor & Employer	Receipt at site of first lot of the Plant and Equipment	Up to Operational Acceptance

- (II) The Contractor shall take the policy in the joint name of Employer and the Contractor. All these policies shall indicate Employer as the beneficiary. The policy shall be kept valid till the date of the Operational Acceptance of the project and the period of the coverage shall be determined with the approval of the Employer.

If the work is completed earlier than the period of policy considered, the Contractor shall obtain the refund as per provisions of the policy and pass on the benefit to Employer. In case no refund is payable by the insurance company then the certificate to that effect shall be submitted to Employer at the completion of the project.

- (III) The following add-on covers shall also be taken by the Contractor:

- i) Earthquake
- ii) Terrorism
- iii) Escalation cost (approximately @10% of sum insured on annual basis)
- iv) Extended Maintenance cover for Defect Liability Period
- v) Design Defect
- vi) Other add-on covers viz., 50-50 clause, 72 hours clause, loss minimization clause, waiver of subrogation clause (for projects of more than Rs.100 crores, cover for offsite storage/fabrication (over Rs.100 crores).

(IV) ***Third Party Liability cover with cross Liability within Geographical limits of India as on ADD-on cover to the basic EAR cover:***

The third party liability add-on cover shall cover bodily injury or death suffered by third parties (including the Employer's personnel) and loss of or damage to property (including the Employer's property and any parts of the Facilities which have been accepted by the Employer) occurring in connection with supply and installation of the Facilities.

Amount	Deductible limits	Parties insured	From	To
<ul style="list-style-type: none"> <li>• For projects upto Rs. 100 crores, the third party liability limit shall be 10% of the project value for single occurrence/ multiple occurrences in aggregate during the entire policy period.</li> <li>• For projects from Rs. 100 crores to Rs. 500 crores, the third party liability limit shall be Rs. 10 crores for single occurrence/multiple occurrences in aggregate during entire policy period. For projects of more than Rs.500 crores, the third party liability limit shall be Rs. 25 crores for single occurrence/ multiple occurrences in</li> </ul>	Nil	Contractor/ Sub- Contractor	Receipt at site	Upto Defect Liability Period.

aggregate during entire policy period.				
---	--	--	--	--

- (V) As per GCC Clause 30.8, the cost of insurance premium is to be reimbursed to the Contractor for Owner Supplied Materials (OSM) for which the insurer is to be finalized by the Contractor as detailed therein. Alternatively, the Contractor may take a single policy covering the entire cost of the project including the cost of OSM. For this purpose, the Contractor shall submit documentary evidence for the premium paid for the entire project to the Employer and Employer shall reimburse to the Contractor the proportion of premium equal to value of OSM to total sum insured.

If during the execution of Contract, the Employer requests the Contractor to take any other add-on cover(s)/ supplementary cover(s) in aforesaid insurance, in such a case, the Contractor shall promptly take such add-on cover(s)/ supplementary cover(s) and the charges towards such premium for such add-on cover(s)/ supplementary cover(s) shall be reimbursed to the Contractor on submission documentary evidence of payment to the Insurance company. Therefore, charges towards premium for such add-on cover(s)/ supplementary cover(s) are not included in the Contract Price.

**(c) Automobile Liability Insurance**

The Contractor shall ensure that all the vehicles deployed by the Contractor or its Subcontractor (whether owned by them) in connection with the supply and installation of the Facilities in the project are duly insured as per RTA act. Further the Contractor or its Subcontractors may also take comprehensive policy (own damage plus third-party liability) of each individual vehicle deployed in the project on their own discretion in their own name to protect their own interest.

**(d) Workmen Compensation Policy:**

- (I) Workmen Compensation Policy shall be taken by the Contractor in accordance with the statutory requirement applicable in India. The Contractor shall ensure that all the workmen employed by the Contractor or its Subcontractors for the project are adequately covered under the policy.
- (II) The policy may either be project specific covering all men of the Contractor and its Subcontractors. The policy shall be kept valid till the date of Operational Acceptance of the project.

Alternatively, if the Contractor has an existing 'Workmen Compensation Policy' for all its employees including that of the Subcontractor(s), the

Contractor must include the interest of the Employer for this specific Project in its existing ‘Workmen Compensation Policy’.

- (III) Without relieving the Contractor of its obligations and responsibilities under this Contract, before commencing work the Contractor shall insure against liability for death of or injury to persons employed by the Contractor including liability by statute and at common law. The insurance cover shall be maintained until all work including remedial work is completed including the Defect Liability Period. The insurance shall be extended to indemnify the Principal for the Principal’s statutory liability to persons employed by the Contractor.

The Contractor shall also ensure that each of its Subcontractors shall affect and maintain insurance on the same basis as the ‘Workmen Compensation Policy’ effected by the Contractor.

(e) **Contractor’s Plant and Machinery (CPM) Insurance**

The Employer (including without limitation any consultant, servant, agent or employee of the Employer) shall not in any circumstances be liable to the Contractor for any loss of or damage to any of the Contractor’s Equipment or for any losses, liabilities, costs, claims, actions or demands which the Contractor may incur or which may be made against it as a result of or in connection with any such loss or damage.

The Employer shall be named as co-insured under all insurance policies taken out by the Contractor pursuant to GCC Sub-Clause 34.2, except for the Third-Party Liability, Workmen Compensation Policy Insurances, and the Contractor’s Subcontractors shall be named as co-insureds under all insurance policies taken out by the Contractor pursuant to GCC Sub-Clause 34.2 except for the Cargo Insurance During Transport and Workmen Compensation

Policy Insurances. All insurer’s rights of subrogation against such co-insureds for losses or claims arising out of the performance of the Contract shall be waived under such policies.

**B) Insurances to be taken out by the Employer**

The Employer shall at its expense take out and maintain in effect during the performance of the Contract the following insurances.

Amount	Deductible limits	Parties Insured	From	To
_____ NIL _____				

-- End --

#### Appendix-4 : TIME SCHEDULE

1. The Project Completion Schedule shall be as follows: As per 2.2.13 (Project Timelines)

1.1 The activity(ies) under the Contractor's programme for Project Completion shall be in the form a PERT chart and shall identify the various activities like engineering, vendor finalization, placement of orders to sub-vendors, survey, Resource mobilization, erection, testing & commissioning including submission of closure proposals. Format of PERT chart is enclosed . The PERT Chart shall conform to the above Project Completion Schedule.

This PERT Chart shall be discussed and agreed before Award in line with above, engineering drawing and data submission schedule shall also be discussed and finalised before Award. Liquidated damages for delay in successful Completion of the Facilities or specific part thereof (where specific parts are specified in SCC) and Operational Acceptance at rates specified in Clause 26 of GCC shall be applicable beyond the date specified above.

1.2 The Employer reserves the right to request minor changes in the work schedule at the time of Award of Contract to the successful Bidder.

1.3 The successful Bidder shall be required to prepare detailed PERT Chart and finalise the same with the Employer as per the requirement, which shall form a part of the Contract.

1.4 In case of new substations the date of start of the works shall be counted from the date of land made available to the Contractor by the employer.

1.5 The start date of the contract will be the date of contract signing between the Contractor and employer. In the L1 and L2 schedule all the milestone timelines should be from the date of start of contract.

## Appendix-5 : LIST OF APPROVED SUBCONTRACTORS

Prior to award of Contract, the following details shall be completed indicating those sub-Contractors proposed by the Bidder by Attachment to its bid that are approved by the Employer for engagement by the Contractor during the performance of the contract.

The following Subcontractors are approved for carrying out the item of the facilities indicated. Where more than one Subcontractor is listed, the Contractor is free to choose between them, but it must notify the Employer of its choice in good time prior to appointing any selected Subcontractor. In accordance with GCC Sub-Clause 19.1, the Contractor is free to submit proposals for Subcontractors for additional items from time to time. No Subcontracts shall be placed with any such Subcontractors for additional items until the Subcontractors have been approved in writing by the Employer and their names have been added to this list of Approved Subcontractors.

Item of Facilities	Approved Subcontractors	Nationality

***Further, erection portion of the contract shall not be subcontracted without the prior approval of the Employer. However, such approval shall not be necessary for engaging labour.***

### Appendix-6 : SCOPE OF WORKS AND SUPPLY BY THE EMPLOYER

The following personnel, facilities, works and supplies will be provided/supplied by the Employer, and the provisions of GCC 10, 20, 21 and 24 as well as Employer responsibilities stated in technical specifications shall apply as appropriate.

All personnel, facilities, works and supplies will be provided by the Employer in good time so as not to delay the performance of the Contractor in accordance with the approved Time Schedule and Program of Performance pursuant to GCC Sub-Clause 18.2.

Unless otherwise indicated, all personnel, facilities, works and supplies will be provided free of charge to the Contractor.

Personnel Charge to Contractor – None

-----NIL-----

Facilities Charge to Contractor - None except as noted

Electricity and Water Charge to Contractor - as noted

The Contractor shall be entitled to use for the purposes of the facilities such supplies of electricity and water as may be available on the Site and shall provide any apparatus necessary for such use. The Contractor shall pay the Employer at the applicable tariff plus Employer's overheads, if any, for such use. Where such supplies are not available, the Contractor shall make his own arrangement for provision of any supplies he may require.

Works Charge to Contractor - None

-----NIL-----

Supplies Charge to Contractor – None

-----NIL-----

### Appendix-7 :LIST OF DOCUMENTS FOR APPROVAL OR REVIEW

Pursuant to GCC Sub-Clause 20.3.1, the Contractor shall prepare, or cause its Subcontractor to prepare, and present to the Project Manager in accordance with the requirements of GCC Sub-Clause 18.2 (Program of Performance), the following documents for:

#### A. Approval

- 1.
- 2.
- 3.

#### B. Review

- 1.
- 2.
- 3.

Note:

Bidder shall furnish the exhaustive list, which shall be discussed and finalised for incorporation into the Contract Agreement.



### Appendix-8 :GUARANTEES, LIQUIDATED DAMAGES FOR NON – PERFORMANCE

1. The equipment offered shall meet the rating and performance requirements stipulated in Technical Specification for various equipment or indicated in Data requirement.
2. The ratings and performance figures of the below mentioned equipment are guaranteed as per losses given in respective Indian Standard (up to date) by bidder.

Sl. No.	Description
A.	<del>12/10/8/6.3/5/3.15/1.6 MVA 33/11kV, 3 ph. Power Transformer</del>
B.	<del>1000/630/500/315/200/100/63/25/16KVA, 11/0.433kV, 3 phase Station &amp; Distribution Transformer</del>
C.	<del>16/10KVA, 11/0.250kV, 1 phase Distribution Transformer</del>

3. If the aforementioned guarantees are not established at factory tests, then the Employer shall reject the equipment.

## 6. PERFORMANCE SECURITY FORM

Bank Guarantee No. ....

Date.....

Contract No.....

.....[Name of Contract] .....

To:[Name and address of Employer]

Dear Ladies and/or Gentlemen,

We refer to the Contract ("the Contract") signed on .....(insert date of the Contract)..... between M/s. WBSEDCL, having its Registered Office at XXXXX (Registered Address of employer) ("the Employer"/" WBSEDCL") **on behalf of XXXX (Name of owner) (hereinafter referred to as 'XXXX (Short Name of Owner)' / 'Owner')**, and M/s ..... (Name of Contractor) ....., having its Principal place of business at .....(Address of Contractor) ..... and Registered Office at .....(Registered address of Contractor) ..... ("the Contractor") concerning .....(Indicate brief scope of work) ..... for the complete execution of the ..... (insert name of Package along with name of the Project).....  
*[Applicable for Bank Guarantees issued by Contractor/Associate for those Contracts awarded to them]*

**Or**

We refer to the Contract signed on .....(insert date of the Contract) ..... between M/s. WBSEDCL, having its Registered Office at XXXXX (Registered Address of employer) ("the Employer"/" WBSEDCL") **on behalf of XXXX (Name of owner) (hereinafter referred to as 'XXXX (Short Name of Owner)' / 'Owner')**, and M/s ..... (Name of Contractor) ....., having its Principal place of business at .....(Address of Contractor) ..... and Registered Office at .....(Registered address of Contractor) ..... ("the Contractor") and the Contract ("the Contract") signed on .....(insert date of the Contract)..... between WBSEDCL **on behalf of Owner** and M/s ..... (Name of Associate) ....., having its Principal place of business at .....(Address of Associate) ..... and Registered Office at .....(Registered address of Associate) ....., the Associate of the Contractor for executing the Facilities concerning ..... (Indicate brief scope of work) ..... for the complete execution of the ..... (insert name of Package along

*with name of the Project)..... [Applicable for Bank Guarantees to be issued by Contractor against those Contracts awarded to their Associate]*

By this letter we, the undersigned, .....(insert name & address of the issuing bank) ....., a Bank (which expression shall include its successors, administrators, executors and assigns) organized under the laws of ..... and having its Registered/Head Office at .....(insert address of registered office of the bank)..... do hereby irrevocably guarantee payment to the Employer up to ..... i.e., Ten percent (10%) of the Contract Price until thirty (30) days beyond the Defect Liability Period i.e., upto and inclusive of ..... (dd/mm/yy).

We undertake to make payment under this Letter of Guarantee upon receipt by us of your first written demand signed by the Employer duly authorized officer or the authorized officer of **Owner** declaring the Contractor to be in default under the Contract and without cavil or argument any sum or sums within the above named limits, without your need to prove or show grounds or reasons for your demand and without the right of the Contractor to dispute or question such demand.

Our liability under this Letter of Guarantee shall be to pay to the Employer whichever is the lesser of the sum so requested or the amount then guaranteed hereunder in respect of any demand duly made hereunder prior to expiry of the Letter of Guarantee, without being entitled to inquire whether or not this payment is lawfully demanded.

This letter of Guarantee shall remain in full force and shall be valid from the date of issue until thirty (30) days beyond the Defect Liability Period of the Facilities i.e. upto and inclusive of ..... (dd/mm/yy) and shall be extended from time to time for such period (not exceeding one year), as may be desired by M/s. .... on whose behalf this Letter of Guarantee has been given.

Except for the documents herein specified, no other documents or other action shall be required, notwithstanding any applicable law or regulation.

Our liability under this Letter of Guarantee shall become null and void immediately upon its expiry, whether it is returned or not, and no claim may be made hereunder after such expiry or after the aggregate of the sums paid by us to the Employer shall equal the sums guaranteed hereunder, whichever is the earlier.

All notices to be given under shall be given by registered (airmail) posts to the addressee at the address herein set out or as otherwise advised by and between the parties hereto.

We hereby agree that any part of the Contract may be amended, renewed, extended, modified, compromised, released or discharged by mutual agreement between you and the Contractor, and this security may be exchanged or surrendered without in any way impairing or affecting our liabilities hereunder without notices to us and without the

necessity for any additional endorsement, consent or guarantee by us, provided, however, that the sum guaranteed shall not be increased or decreased.

No action, event or condition which by any applicable law should operate to discharge us from liability hereunder shall have any effect and we hereby waive any right we may have to apply such law so that in all respects our liability hereunder shall be irrevocable and, except as stated herein, unconditional in all respects.

For and on behalf of the Bank

[*Signature of the authorised signatory(ies)*]

Signature\_\_\_\_\_

Name\_\_\_\_\_

Designation\_\_\_\_\_

POA Number\_\_\_\_\_

Contact Number(s): Tel.\_\_\_\_\_ Mobile\_\_\_\_\_

Fax Number\_\_\_\_\_

email \_\_\_\_\_

Common Seal of the Bank\_\_\_\_\_

Witness:

Signature\_\_\_\_\_

Name\_\_\_\_\_

Address\_\_\_\_\_

Contact Number(s): Tel.\_\_\_\_\_ Mobile\_\_\_\_\_

email \_\_\_\_\_

**Note :**

1. For the purpose of executing the Bank Guarantee, the non-judicial stamp papers of appropriate value shall be purchased in the name of Bank who issues the 'Bank Guarantee'.
2. The Bank Guarantee shall be signed on all the pages by the Bank Authorities indicating their POA nos. and should invariably be witnessed.
3. The Bank Guarantee should be in accordance with the proforma as provided. However, in case the issuing bank insists for additional paragraph for limitation of liability, the following may be added at the end of the proforma of the Bank Guarantee [*i.e., end paragraph of the Bank Guarantee preceding the signature(s) of the issuing authority(ies) of the Bank Guarantee*]:

Quote

“Notwithstanding anything contained herein:

1. Our liability under this Bank Guarantee shall not exceed \_\_\_\_\_ (*value in figures*)\_\_\_\_\_ [*\_\_\_\_\_ (value in words)*\_\_\_\_\_].
2. This Bank Guarantee shall be valid upto\_\_\_\_\_(*validity date*)\_\_\_\_\_.
3. We are liable to pay the guaranteed amount or any part thereof under this Bank Guarantee only & only if we receive a written claim or demand on or before \_\_\_\_\_ (*validity date*) \_\_\_\_\_.”

Unquote

## 7. BANK GUARANTEE FORM FOR ADVANCE PAYMENT

Bank Guarantee No. ....

Date.....

Contract No.....

.....[*Name of Contract*] .....

To:[*Name and address of the Employer*]

Dear Ladies and/or Gentlemen,

We refer to the Contract ("the Contract") signed on .....(*insert date of the Contract*)..... between you and M/s ..... (*Name of Contractor*) ....., having its Principal place of business at .....(*Address of Contractor*) ..... and Registered Office at .....(*Registered address of Contractor*) ..... ("the Contractor") concerning .....(*Indicate brief scope of work*) ..... for the complete execution of the ..... (*insert name of Package along with name of the Project*).....

Whereas, in accordance with the terms of the said Contract, the Employer has agreed to pay or cause to be paid to the Contractor an Advance Payment in the amount of .....(*Amount in figures and words*).....

By this letter we, the undersigned, .....(*insert name & address of the issuing bank*) ....., a Bank (which expression shall include its successors, administrators, executors and assigns) organized under the laws of ..... and having its Registered/Head Office at .....(*insert address of registered office of the bank*)..... do hereby irrevocably guarantee repayment of the said amounts upon the first demand of the Employer without cavil or argument in the event that the Contractor fails to commence or fulfill its obligations under the terms of the said Contract, and in the event of such failure, refuses to repay all or part (as the case may be) of the said advance payment to the Employer.

Provided always that the Bank's obligation shall be limited to an amount equal to the outstanding balance of the advance payment, taking into account such amounts, which have been repaid by the Contractor from time to time in accordance with the terms of payment of the said Contract as evidenced by appropriate payment certificates.

This Guarantee shall remain in full force from the date upon which the said advance payment is received by the Contractor upto thirty (30) days beyond the date on which the

entire advance so advanced along with the interest if any due thereon has been fully adjusted in terms of the Contract i.e., upto of thirty (30) days beyond the date of Completion of the Facilities under the Contract. This Guarantee may be extended from time to time, as may be desired by M/s. .... on whose behalf this Guarantee has been issued.

Any claims to be made under this Guarantee must be received by the Bank during its period of validity, i.e.uptothirty (30) days beyond the date of Completion of the Facilities by the Employer i.e. upto and inclusive of ..... (dd/mm/yy).

For and on behalf of the Bank

[Signature of the authorised signatory(ies)]

Signature\_\_\_\_\_

Name\_\_\_\_\_

Designation\_\_\_\_\_

POA Number\_\_\_\_\_

Contact Number(s): Tel.\_\_\_\_\_ Mobile\_\_\_\_\_

Fax Number\_\_\_\_\_

email \_\_\_\_\_

Common Seal of the Bank\_\_\_\_\_

Witness:

Signature\_\_\_\_\_

Name\_\_\_\_\_

Address\_\_\_\_\_

Contact Number(s): Tel.\_\_\_\_\_ Mobile\_\_\_\_\_

email \_\_\_\_\_

**Note:**

1. For the purpose of executing the Bank Guarantee, the non-judicial stamp papers of appropriate value shall be purchased in the name of Bank who issues the 'Bank Guarantee'.
2. The Bank Guarantee shall be signed on all the pages by the Bank Authorities indicating their POA nos. and should invariably be witnessed.
3. The Bank Guarantee should be in accordance with the proforma as provided. However, in case the issuing bank insists for additional paragraph for limitation of liability, the following may be added at the end of the proforma of the Bank Guarantee [*i.e., end paragraph of the Bank Guarantee preceding the signature(s) of the issuing authority(ies) of the Bank Guarantee*]:

Quote

“Notwithstanding anything contained herein:

1. Our liability under this Bank Guarantee shall not exceed \_\_\_\_\_ (*value in figures*)\_\_\_\_\_ [*\_\_\_\_\_ (value in words)*\_\_\_\_\_].
2. This Bank Guarantee shall be valid upto\_\_\_\_\_(*validity date*)\_\_\_\_\_.
3. We are liable to pay the guaranteed amount or any part thereof under this Bank Guarantee only & only if we receive a written claim or demand on or before \_\_\_\_\_ (*validity date*) \_\_\_\_\_.”

Unquote



## 8. FORM OF COMPLETION CERTIFICATE

Date.....

Name of Contract.....

Contract No.....

To :

(Name and address of the Contractor)

Dear Ladies and/or Gentlemen,

Pursuant to GCC 24.4 (Completion) of the General Conditions of the Contract entered into between yourselves and the Employer dated ..... relating to the .....(*insert brief description of the Facilities*)..... we hereby notify you that the following part(s) of the Facilities was (were) complete on the date specified below, and that, in accordance with the terms of the Contract, the Employer hereby takes over the said part(s) of the Facilities, together with the responsibility for care and custody and the risk of loss thereof on the date mentioned below :

1. Description of the Facilities or part thereof .....
2. Date of Completion :.....

However, you are required to complete the outstanding items listed in the attachment hereto as soon as practicable.

This letter does not relieve you of your obligation to complete the execution of the Facilities in accordance with the Contract nor of your obligations during the Defects Liability Period.

Very truly yours,

Title

(Project Manager)

**9. FORM OF INDEMNITY BOND TO BE EXECUTED BY THE CONTRACTOR FOR THE EQUIPMENT HANDED OVER IN ONE LOT BY .....(abbreviated name of the Employer)..... FOR PERFORMANCE OF ITS CONTRACT**

**INDEMNITY BOND**

THIS INDEMNITY BOND is made this..... day of ..... 20.... by ..... a Company registered under the Companies Act, 1956/2013 (with amendment from time to time)/Partnership firm/ proprietary concern having its Registered Office at.....(hereinafter called as 'Contractor' or "Obligor" which expression shall include its successors and permitted assigns) in favour of ..... (*insert name of the Employer*)....., a Company incorporated under the Companies Act, 1956/2013 (with amendment from time to time) having its Registered Office at .....(*insert registered address of the Employer*)and its project at ..... (hereinafter called "*.....(abbreviated name of the Employer).....*") which expression shall include its successors and assigns):

WHEREAS .....(*abbreviated name of the Employer*)..... has awarded to the Contractor a Contract for..... vide its Notification of Award/Contract No..... dated..... and its Amendment No. .... (applicable when amendments have been issued) (hereinafter called the "Contract") in terms of which .....(*abbreviated name of the Employer*)..... is required to hand over various Equipment to the Contractor for execution of the Contract.

And WHEREAS by virtue of Clause No.....of the said Contract, the Contractor is required to execute an Indemnity Bond in favour of .....(*abbreviated name of the Employer*)..... for the Equipment handed over to it by .....(*abbreviated name of the Employer*)..... for the purpose of performance of the Contract/Erection portion of the contract (hereinafter called the "Equipment").

AND THEREFORE, This Indemnity Bond witnesseth as follows:

1. That in consideration of various Equipment as mentioned in the Contract, valued at (amount in words.....) handed over to the Contractor for the purpose of performance of the Contract, the Contractor hereby undertakes to indemnify and shall keep .....(*abbreviated name of the Employer*)..... indemnified, for the full value of the Equipment. The Contractor hereby acknowledges receipt of the Equipment as per dispatch title documents handed over to the Contractor duly endorsed in their favour and detailed in the Schedule appended hereto. It is expressly understood by the Contractor that handing over of the dispatch title documents in respect of the said Equipments duly endorsed by .....(*abbreviated name of the Employer*)..... in favour of the Contractor shall be

construed as handing over of the Equipment purported to be covered by such title documents and the Contractor shall hold such Equipment in trust as a Trustee for and on behalf of .....(*abbreviated name of the Employer*).....

2. That the Contractor is obliged and shall remain absolutely responsible for the safe transit/protection and custody of the Equipment at .....(*abbreviated name of the Employer*)..... project Site against all risks whatsoever till the Equipment are duly used/erected in accordance with the terms of the Contract and the Plant/Package duly erected and commissioned in accordance with the terms of the Contract, is taken over by .....(*abbreviated name of the Employer*)..... The Contractor undertakes to keep .....(*abbreviated name of the Employer*)..... harmless against any loss or damage that may be caused to the Equipment.
3. The Contractor undertakes that the Equipment shall be used exclusively for the performance/execution of the Contract strictly in accordance with its terms and conditions and no part of the equipment shall be utilised for any other work of purpose whatsoever. it is clearly understood by the Contractor that non-observance of the obligations under this Indemnity Bond by the Contractor shall inter-alia constitute a criminal breach of trust on the part of the Contractor for all intents and purpose including legal/penal consequences.
4. That .....(*abbreviated name of the Employer*)..... is and shall remain the exclusive Employer of the Equipment free from all encumbrances, charges or liens of any kind, whatsoever. The equipment shall at all times be open to inspection and checking by the Employee or Employer's Representative in this regard. Further, .....(*abbreviated name of the Employer*)..... shall always be free at all times to take possession of the Equipment in whatever form the equipment may be, if in its opinion, the Equipment are likely to be endangered, misutilised or converted to uses other than those specified in the Contract, by any acts of omission or commission on the part of the Contractor or any other person or on account of any reason whatsoever and the Contractor binds himself and undertakes to comply with the directions of demand of .....(*abbreviated name of the Employer*)..... to return the equipment without any demur or reservation.
5. That this indemnity Bond is irrevocable. If at any time any loss or damage occurs to the Equipment or the same or any part thereof is misutilised in any manner whatsoever, then the Contractor hereby agrees that the decision of the Employer's Representative as to assessment of loss or damage to the Equipment shall be final and binding on the Contractor. The Contractor binds itself and undertakes to replace the lost and/or damaged Equipment at his own cost and/or shall pay the amount of loss to .....(*abbreviated name of the Employer*).....without any demur, reservation or protest. This is without prejudice to any other right or remedy that may be available to .....(*abbreviated name of the*

*Employer*).....against the Contractor under the Contract and under this Indemnity Bond.

6. NOW THE CONDITION of this Bond is that if the Contractor shall duly and punctually comply with the terms and conditions of this Bond to the satisfaction of .....(*abbreviated name of the Employer*)....., THEN, the above Bond shall be void, but otherwise, it shall remain in full force and virtue.

IN WITNESS WHEREOF, the Contractor has hereunto set its hand through its authorized representative under the common seal of the Company, the day, month and year first above mentioned.

#### SCHEDULE

Particulars of the Equipment handed over	Quantity	Particulars of Dispatch title Documents		Value of the Equipment	Signature of the Attorney in token of receipt
		RR/GR No. date of lading	Carrier		

For and on behalf of  
M/s.....

#### WITNESS

1. Signature.....

Signature.....

Name.....

Name.....

Address.....

Address.....

2. Signature.....

Authorised representative

Name.....

(Common Seal)

Address.....

(In case of Company)

Indemnity Bonds are to be executed by the authorised person and (i) in case of contracting Company under common seal of the Company or (ii) having the power of attorney issued under common seal of the company with authority to execute Indemnity Bonds, (iii) In

case of (ii), the original Power of Attorney if it is specifically for this Contract or a Photostat copy of the Power of Attorney if it is General Power of Attorney and such documents should be attached to Indemnity Bond.

**10. FORM OF INDEMNITY BOND TO BE EXECUTED BY THE  
CONTRACTOR FOR THE EQUIPMENT HANDED OVER IN  
INSTALLMENTS BY .....(abbreviated name of the Employer)..... FOR  
PERFORMANCE OF ITS CONTRACT**

**INDEMNITY BOND**

THIS INDEMNITY BOND is made this ..... day of ..... 20..... by ..... a Company registered under the Companies Act, 1956/2013 (with amendment from time to time)/Partnership firm/proprietary concern having its Registered Office at .....(hereinafter called as 'Contractor' or 'Obligor' which expression shall include its successors and permitted assigns) in favour of .....(*insert name of the Employer*)....., a company incorporated under the Companies Act, 1956/2013 (with amendment from time to time) having its Registered Office at .....(*insert registered address of the Employer*)..... and its project at ..... (hereinafter called".....(*abbreviated name of the Employer*)....." which expression shall include its successors and assigns):

WHEREAS .....(*abbreviated name of the Employer*)..... has awarded to the Contractor a Contract for .....vide its Notification of Award/Contract No. .... dated .....and Amendment No. .... (applicable when amendments have been issued) (hereinafter called the "Contract") in terms of which .....(*abbreviated name of the Employer*)..... is required to handover various Equipment to the Contractor for execution of the Contract.

AND WHEREAS by virtue of Clause No.....of the said Contract, the Contractor is required to execute an Indemnity Bond in favour of .....(*abbreviated name of the Employer*)..... for the Equipment handed over to it by .....(*abbreviated name of the Employer*)..... for the purpose of performance of the contract/Erection portion of the Contract (hereinafter called the "Equipment".)

NOW THEREFORE, This Indemnity Bond witnesseth as follows:

1. That in consideration of various Equipments as mentioned in the Contract, valued at (amount in words \_\_\_\_\_) to be handed over to the Contractor in installments from time to time for the purpose of performance of the contract, the Contractor hereby undertakes to indemnify and shall keep .....(*abbreviated name of the Employer*).....indemnified, for the full value of Equipment. The Contractor hereby acknowledges receipt of the initial installment of the equipment per details in the schedule appended hereto. Further, the Contractor agrees to acknowledge receipt of the subsequent installments of the Equipment as required by .....(*abbreviated name of the Employer*)..... in the form of Schedules consecutively numbered which shall be attached to this Indemnity bond so as to

form integral parts of this Bond. It is expressly understood by the Contractor that handing over the dispatch title documents in respect of the said Equipments duly endorsed by .....(*abbreviated name of the Employer*)..... in favour of the Contractor shall be construed as handing over the Equipment purported to be covered by such title documents and the Contractor shall hold such Equipments in trust as a Trustee for and on behalf of .....(*abbreviated name of the Employer*).....

2. That the Contractor is obliged and shall remain absolutely responsible for the safe transit/protection and custody of the Equipment at .....(*abbreviated name of the Employer*)..... project Site against all risks whatsoever till the Equipment are duly used/erected in accordance with the terms of the Contract and the Plant/Package duly erected and commissioned in accordance with the terms of the Contract, is taken over by .....(*abbreviated name of the Employer*)..... The Contractor undertakes to keep .....(*abbreviated name of the Employer*)..... harmless against any loss or damage that may be caused to the Equipment.
3. The Contractor undertakes that the Equipment shall be used exclusively for the performance/execution of the Contract strictly in accordance with its terms and conditions and no part of the equipment shall be utilised for any other work or purpose whatsoever. It is clearly understood by the Contractor that non-observance of the obligations under this Indemnity Bond by the Contractor shall inter-alia constitute a criminal breach of trust on the part of the Contractor for all intents and purpose including legal/penal consequences.
4. That .....(*abbreviated name of the Employer*)..... is and shall remain the exclusive Employer of the Equipment free from all encumbrances, charges or liens of any kind, whatsoever. The equipment shall at all times be open to inspection and checking by the Employer or Employer's Representative in this regard. Further, .....(*abbreviated name of the Employer*)..... shall always be free at all times to take possession of the Equipment in whatever form the Equipment may be, if in its opinion, the Equipment are likely to be endangered, misutilised or converted to uses other than those specified in the Contract, by any acts of omission or commission on the part of the Contractor or any other person or on account of any reason whatsoever and the Contractor binds himself and undertakes to comply with the directions of demand of .....(*abbreviated name of the Employer*)..... to return the equipment without any demur or reservation.
5. That this indemnity Bond is irrevocable. If at any time any loss or damage occurs to the Equipment or the same or any part thereof is misutilised in any manner whatsoever, then the Contractor hereby agrees that the decision of the Employer's Representative as to assessment of loss or damage to the Equipment shall be final and binding on the Contractor. The Contractor binds itself and undertakes to replace the lost and/or damaged Equipment at its own cost and/or shall pay the amount of loss to .....(*abbreviated name of the Employer*)..... without any demur, reservation

or protest. This is without prejudice to any other right or remedy that may be available to .....(*abbreviated name of the Employer*)..... against the Contractor under the Contract and under this Indemnity Bond.

6. NOW THE CONDITION of this Bond is that if the Contractor shall duly and punctually comply with the terms and conditions of this Bond to the satisfaction of .....(*abbreviated name of the Employer*)....., THEN, the above Bond shall be void, but otherwise, it shall remain in full force and virtue.

IN WITNESS WHEREOF, the Contractor has hereunto set its hand through its authorised representative under the common seal of the Company, the day, month and year first above mentioned.

SCHEDULE No. 1

Particulars of the Equipment handed over	Quantity	Particulars of Dispatch title Documents		Value of the Equipment	Signature of the Attorney in token of receipt
		RR/GR No. date of lading	Carrier		

For and on behalf of  
M/s.....

WITNESS

1. Signature.....

Signature.....

Name.....

Name.....

Address.....

Address.....

2. Signature.....

Authorised representative

Name.....

(Common Seal)

Address.....

(In case of Company)



Indemnity Bonds are to be executed by the authorised person and (i) in case of contracting Company under common seal of the Company or (ii) having the power of attorney issued under common seal of the company with authority to execute Indemnity Bonds, (iii) In case of (ii), the original Power of Attorney if it is specifically for this Contract or a photostat copy of the Power of Attorney if it is General Power of Attorney and such documents should be attached to Indemnity Bond.

## 11. FORM OF AUTHORISATION LETTER

Ref. No:

Date :

To

M/s.....

.....

.....

REF.: Contract No. .... dated ..... for .....  
awarded by ....(*insert name of the Employer*).....

Dear Sir,

Kindly refer to Contract No. .... dated ..... for ..... You are hereby authorised on behalf of ..... (*Name of Employer*)..... a company incorporated under the laws of Companies Act 1956/2013 (with amendment from time to time) and having its Registered Office at .....(*registered address of the Employer*) .....and its Project at ..... to take physical delivery of materials/equipments covered under Dispatch Document/Consignment Note No. ....\*..... dated .....and as detailed in the enclosed schedule for the sole purpose of successful performance of the aforesaid contract and for no other purpose, whatsoever.

(Signature of Project Authority)\*\*

Designation.....

Date.....

Encl: As Above.

\*\* To be signed not below the rank of Manager.

\* Mention LR/RR No.

Schedule of Material/Equipment covered under Dispatch Title Document (RR No./LR No. ....)

<b>Sl. No.</b>	<b>Contract Name</b>	<b>NOA No./ CA No.</b>	<b>Description of Materials/ Equipments</b>	<b>Spec. No.</b>	<b>Qty.</b>	<b>Value</b>	<b>Remarks</b>

(Signature of the Project Authority)

(Designation) .....

(Date) .....

## 12. FORM OF TRUST RECEIPT FOR PLANT, EQUIPMENT AND MATERIALS RECEIVED

We M/s. ....(*insert name of the Contractor*) ..... having our Principal place of business at ..... having been awarded a Contract No. .... dated ..... for ..... (*insert Package name along with name of the Project*)..... by .....(*insert name of the Employer*) .....

We do hereby acknowledge the receipt of the Plant, Equipment and Materials as are fully described and mentioned under Documents of Title/RR/LR etc. and in the schedule annexed hereto, which shall form an integral part of this receipt as "Trustee" of ..... (*insert name of the Employer*)..... The aforesaid materials etc. so received by us shall be exclusively used in the successful performance of the aforesaid Contract and for no other purpose whatsoever. We undertake not to create any charge, lien, or encumbrance over the aforesaid materials etc., in favour of any other person/institution(s)/Banks.

For M/s .....  
(*Contractor's Name*)

Dated : .....

(AUTHORISED SIGNATORY)

Place : .....

SEAL OF COMPANY

**13. FORM OF EXTENSION OF BANK GUARANTEE**

Ref. No.....

Dated:.....

To: *[Name and address of the Employer]*

Dear Sirs,

Sub.: Extension of Bank Guarantee No. .... dated ..... for  
 ....., issued to you on behalf of M/s. ....(*insert name of the Contractor*)  
 ..... in respect of Contract No. .... dated ..... for  
 ....(*insert name of the Package along with the Project name*) .....(hereinafter  
 called original Bank Guarantee).

At the request of M/s..... (*insert name of the Contractor*) ....., We  
 .....(*insert name & address of the issuing bank*) ....., a Bank organized under the  
 laws of ..... and having its Registered/Head Office at .....(*insert address  
 of registered office of the bank*)..... do hereby extend our liability under the  
 above-mentioned Guarantee No. .... Dated ..... for a further  
 period of ..... Years/Months from ..... to expire on ..... Except as  
 provided above, all other terms and conditions of the original Bank Guarantee No.  
 ..... dated ..... shall remain unaltered and binding.

Please treat this as an integral part of the original Guarantee to which it would be attached.

For and on behalf of the Bank

[*Signature of the authorised signatory(ies)*]

Signature\_\_\_\_\_

Name\_\_\_\_\_

Designation\_\_\_\_\_

POA Number\_\_\_\_\_

Contact Number(s): Tel.\_\_\_\_\_ Mobile\_\_\_\_\_

Fax Number\_\_\_\_\_

email \_\_\_\_\_

Common Seal of the Bank\_\_\_\_\_

Witness:

Signature\_\_\_\_\_

Name\_\_\_\_\_

Address\_\_\_\_\_

Contact Number(s): Tel.\_\_\_\_\_ Mobile\_\_\_\_\_

email \_\_\_\_\_

**Note:**

1. For the purpose of executing the Bank Guarantee, the non-judicial stamp papers of appropriate value shall be purchased in the name of Bank who issues the 'Bank Guarantee'.
2. The Bank Guarantee shall be signed on all the pages by the Bank Authorities indicating their POA nos. and should invariably be witnessed.

#### 14. FORM OF POWER OF ATTORNEY FOR JOINT VENTURE(JV)

KNOW ALL MEN BY THESE PRESENTS THAT WE , the Partners whose details are given hereunder ..... have formed a Joint Venture(JV) under the laws of ..... and having our Registered Office(s)/Head Office(s) at ..... (hereinafter called the 'Joint Venture(JV)' which expression shall unless repugnant to the context or meaning thereof, include its successors, administrators and assigns) acting through M/s ..... being the Partner in-charge do hereby constitute, nominate and appoint M/s..... a Company incorporated under the laws of ..... and having its Registered/Head Office at ..... as our duly constituted lawful Attorney (hereinafter called "Attorney" or "Authorised Representative" or "Partner In-charge") to exercise all or any of the powers for and on behalf of the Joint Venture(JV) in regard to Specification No..... Package ..... the bids for which have been invited by ..... (insert name of the Employer along with address) ..... (hereinafter called the 'Employer') to undertake the following acts :

- i) To submit proposal and participate in the aforesaid Bid Specification of the Employer on behalf of the "Joint Venture(JV)".
- ii) To negotiate with the Employer the terms and conditions for award of the Contract pursuant to the aforesaid Bid and to sign the Contract with the Employer for and on behalf of the "Joint Venture(JV)".
- iii) To do any other act or submit any document related to the above.
- iv) To receive, accept and execute the Contract for and on behalf of the "Joint Venture(JV)".

It is clearly understood that the Partner In-charge (Lead Partner) shall ensure performance of the Contract(s) and if one or more Partner fail to perform their respective portions of the Contract(s), the same shall be deemed to be a default by all the Partners.

It is expressly understood that this Power of Attorney shall remain valid binding and irrevocable till completion of the Defect Liability Period in terms of the Contract.

The Joint Venture(JV) hereby agrees and undertakes to ratify and confirm all the whatsoever the said Attorney/Authorised Representatives/Partner in-charge quotes in the bid, negotiates and signs the Contract with the Employer and/or proposes to

act on behalf of the Joint Venture(JV) by virtue of this Power of Attorney and the same shall bind the Joint Venture(JV) as if done by itself.

IN WITNESS THEREOF the Partners Constituting the Joint Venture(JV) as aforesaid have executed these presents on this ..... day of ..... under the Common Seal(s) of their Companies.

for and on behalf of the  
Partners of Joint Venture(JV)

.....  
.....  
.....

The Common Seal of the above Partners of the Joint Venture(JV):

The Common Seal has been affixed there unto in the presence of:

WITNESS

1. Signature.....

Name .....

Designation .....

Occupation .....

2. Signature.....

Name .....

Designation .....

Occupation .....

**Note:**

1. For the purpose of executing the Agreement, the non-judicial stamp papers of appropriate value shall be purchased in the name of Joint Venture(JV).
2. The Agreement shall be signed on all the pages by the authorised representatives of each of the partners and should invariably be witnessed.



## 15. FORM OF UNDERTAKING BY THE JOINT VENTURE(JV) PARTNERS

THIS JOINT DEED OF UNDERTAKING executed on this..... day of..... Two Thousand and..... by .....a company incorporated under the laws of ..... and having its Registered Office at .....(hereinafter called the "Party No.1" which expression shall include its successors, executors and permitted assigns) and M/s.....a company incorporated under the laws of ..... and having its Registered Office at ..... (hereinafter called the "Party No.2" which expression shall include its successors, executors and permitted assigns ) and M/s..... a Company incorporated under the laws of ..... and having its Registered Office at ..... (hereinafter called the "Party No.3" which expression shall include its successors, executors and permitted assigns) for the purpose of making a bid and entering into a contract [hereinafter called the "Contract" {in case of award}] against the Specification No..... for ..... (*insert name of the package along with project name*) .....of .....(*insert names of the Employer*) ....., a Company incorporated under the Companies Act of 1956/2013 (with amendment from time to time) having its registered office at .....(*insert registered address of the Employer*)..... (hereinafter called the "Employer").

WHEREAS the Party No.1, Party No.2 and Party No.3 have entered into an Agreement dated.....

AND WHEREAS the Employer invited bids as per the above-mentioned Specification for the design, manufacture, supply, erection, testing and commissioning of Equipment/ Materials stipulated in the Bidding Documents under ..... (*insert name of the package along with project name*) .....

AND WHEREAS Clause 10.2, Section 3 of Part 1 and Section 2 (Eligibility and qualification requirements) of Part-1 forming part of the Bidding Documents, inter-alia stipulates that an Undertaking of two or more qualified manufacturers as partners, meeting the requirements of Section 2, as applicable may bid, provided, the Joint Venture(JV) fulfills all other requirements under Section 2 and in such a case, the Bid Forms shall be signed by all the partners so as to legally bind all the Partners of the Joint Venture(JV), who will be jointly and severally liable to perform the Contract and all obligations hereunder.

The above clause further states that this Undertaking shall be attached to the bid and the Contract performance guarantee will be as per the format enclosed with the Bidding Documents without any restrictions or liability for either party.

AND WHEREAS the bid is being submitted to the Employer vide proposal No.....dated ..... by Party No.1 based on this Undertaking between all the parties; under these presents and the bid in accordance with the requirements of Clause

10.2, Section 3 of Part 1 and Section 2 (Eligibility and qualification requirements) of Part-1, has been signed by all the parties.

NOW THIS UNDERTAKING WITNESSETH AS UNDER:

In consideration of the above premises and agreements all the parties of this Deed of Undertaking do hereby declare and undertake:

1. In requirement of the award of the Contract by the Employer to the Joint Venture(JV) Partners, we, the Parties do hereby undertake that M/s..... the Party No.1, shall act as Lead Partner and further declare and confirm that we the parties to the Joint Venture(JV) shall jointly and severally be bound unto the Employer for the successful performance of the Contract and shall be fully responsible for the design, manufacture, supply and successful performance of the equipment in accordance with the Contract:
2. In case of any breach or default of the said Contract by any of the parties to the Joint Venture(JV), the party(s) do hereby undertake to be fully responsible for the successful performance of the Contract and to carry out all the obligations and responsibilities under the Contract in accordance with the requirements of the Contract.
3. Further, if the Employer suffers any loss or damage on account of any breach in the Contract or any shortfall in the performance of the equipment in meeting the performances guaranteed as per the specification in terms of the Contract, the Party(s) of these presents undertake to promptly make good such loss or damages caused to the Employer, on its demand without any demur. It shall not be necessary or obligatory for the Employer to proceed against Lead Partner to these presents before proceeding against or dealing with the other Party(s), the Employer can proceed against any of the parties who shall be jointly and severally liable for the performance and all other liabilities/obligations under the Contract to the Employer.
4. The financial liability of the Parties of this Deed of Undertaking to the Employer, with respect to any of the claims arising out of the performance or non-performance of the obligations set forth in this Deed of Undertaking, read in conjunction with the relevant conditions of the Contract shall, however, not be limited in any way to restrict or limit the liabilities or obligations of any of the Parties of this Deed of Undertaking.
5. It is expressly understood and agreed between the Parties to this Undertaking that the responsibilities and obligations of each of the Parties shall be as delineated in Appendix – I (*to be suitably appended by the Parties along with this Undertaking in its bid*) to this Deed of Undertaking. It is further undertaken by the parties that

the above sharing of responsibilities and obligations shall not in any way be a limitation of joint and several responsibilities of the Parties under the Contract.

6. It is also understood that this Undertaking is provided for the purposes of undertaking joint and several liabilities of the partners to the Joint Venture(JV) for submission of the bid and performance of the Contract and that this Undertaking shall not be deemed to give rise to any additional liabilities or obligations, in any manner or any law, on any of the Parties to this Undertaking or on the Joint Venture(JV), other than the express provisions of the Contract.
7. This Undertaking shall be construed and interpreted in accordance with the provisions of the Contract.
8. In case of an award of a Contract, we the parties to this Deed of Undertaking do hereby agree that we shall be jointly and severally responsible for furnishing a Contract performance security from a bank in favour of the Employer in the currency/currencies of the Contract.
9. It is further agreed that this Deed of Undertaking shall be irrevocable and shall form an integral part of the bid and shall continue to be enforceable till the Employer discharges the same or upon the completion of the Contract in accordance with its provisions, whichever is earlier. It shall be effective from the date first mentioned above for all purposes and intents.

IN WITNESS WHEREOF, the Parties to this Deed of Undertaking have through their authorised representatives executed these presents and affixed Common Seals of their companies, on the day, month and year first mentioned above.

Common Seal of .....  
has been affixed in my/ our  
presence pursuant to Board of  
Director's Resolution dated .....

For Lead Partner (Party No.-1)  
For and on behalf of M/s  
.....

Name .....

Designation .....

Signature .....

(Signature of the authorized  
representative)

WITNESS :

I. ....

II. ....

Common Seal of .....  
has been affixed in my/ our  
presence pursuant to Board of  
Director’s Resolution dated .....

For Party No.-2  
For and on behalf of  
M/s.....

Name .....

(Signature of the authorized  
representative)

Designation .....

Signature .....

WITNESS :

I. ....

II. ....

Common Seal of .....  
has been affixed in my/ our  
presence pursuant to Board of  
Director’s Resolution dated .....

For Party No.-3  
For and on behalf of M/s.  
.....

Name .....

Designation .....

(Signature of the authorized  
representative)

Signature .....

WITNESS :

I. ....

II. ....

**Note:**

- 1. For the purpose of executing the Joint Deed of Undertaking, the non-judicial stamp papers of appropriate value shall be purchased in the name of Joint Venture(JV).

2. The Undertaking shall be signed on all the pages by the authorised representatives of each of the partners and should invariably be witnessed.

## 16. FORMAT FOR EVIDENCE OF ACCESS TO OR AVAILABILITY OF CREDIT/FACILITIES

### BANK CERTIFICATE

This is to certify that M/s. \_\_\_\_\_ (*insert Name & Address of the Contractor*) \_\_\_\_\_ who have submitted their bid to .....(*insert name of the Employer*)..... against their tender specification Vide ref. No. .... for ..... (*insert name of the package along with the project name*) ..... is our customer for the past ..... years.

Their financial transaction with our Bank have been satisfactory. They enjoy the following fund based and non-fund-based limits including for guarantees, L/C, and other credit facilities with us against which the extent of utilization as on date is also indicated below:

Sl. No.	Type of Facility	Sanctioned Limit as on Date	Utilisation as on Date

This letter is issued at the request of M/s. \_\_\_\_\_.

Signature \_\_\_\_\_

Name of Bank \_\_\_\_\_

Name of Authorised Signatory \_\_\_\_\_

Designation \_\_\_\_\_

Phone No. \_\_\_\_\_

Address \_\_\_\_\_

SEAL OF THE BANK



**17. FORM OF OPERATIONAL ACCEPTANCE**

Date.....

Name of Contract.....

Contract No.....

To :

(Name and address of the Contractor)

Dear Ladies and/or Gentlemen,

Pursuant to GCC 24.4 (Completion) of the General Conditions of the Contract entered into between yourselves and the Employer dated ..... relating to the .....(*insert brief description of the Facilities*)..... we hereby notify you that the we System tests and Acceptance tests of the following part(s) of the Facilities were satisfactorily completed on the date specified below :

1. Description of the Facilities or part thereof .....  
.....
2. Date of Operational Acceptance:.....

This letter does not relieve you of your obligation during the Defects Liability Period and Latent Defect warranty.

Very truly yours,

Title  
(Project Manager)



## **18. FORM OF SAFETY PLAN TO BE SUBMITTED BY THE CONTRACTOR WITHIN SIXTY DAYS OF AWARD OF CONTRACT**

**[TO BE EXECUTED ON A NON JUDICIAL STAMP PAPER WORTH RS. TWENTY ONLY]**

### **SAFETY PLAN**

THIS SAFETY PLAN is made this ..... day of ..... 20..... by ..... a Company registered under the Companies Act, 1956/2013 (with amendment from time to time)/Partnership firm/proprietary concern having its Registered Office at .....[*to be modified suitably for JOINT VENTURE(JV) Contractor*] (hereinafter called as 'Contractor' which expression shall include its successors and permitted assigns) for approval of .....(*insert name of the Employer*)....., a company incorporated under the Companies Act, 1956/2013 (with amendment from time to time) having its Registered Office at .....(*insert registered address of the Employer*)..... for its Contract for ..... (*insert package name, project name along with Specification number of the Contract*).....

WHEREAS .....(*abbreviated name of the Employer*)..... has awarded to the Contractor the aforesaid Contract vide its Notification of Award/Contract No. .... dated .....and Amendment No. .... (applicable when amendments have been issued) (hereinafter called the "Contract") in terms of which the Contractor is required to submit 'Safety Plan' along with certain documents to the Engineer In-Charge/Project Manager of the Employer within Sixty (60) days of Notification of Award for its approval.

NOW THEREFORE, the Contractor undertakes to execute the Contract as per the safety plan as follows:

1. THAT the Contractor shall execute the works as per provisions of Bidding Documents including those in regard to Safety Precautions / provisions as per statutory requirements.
2. THAT the Contractor shall execute the works in a well-planned manner from the commencement of Contract as per agreed mile stones of work completion schedule so that planning and execution of construction works goes smoothly and consistently throughout the contract duration without handling pressure in last quarter of the financial year/last months of the Contract and the shall be finalized in association with WBS&EDCL Engineer In-charge/Project Manager from time to time as required.
3. THAT the Contractor has prepared the safe work procedure for each activity i.e.foundation works including civil works, erection, stringing (as applicable), testing & commissioning, disposal of materials at site / store etc. to be executed at site, which

is enclosed at **Annexure – 1A (SP)** for acceptance and approval of Engineer In-charge/Project Manager. The Contractor shall ensure that on approval of the same from Engineer In-charge/Project Manager, the approved copies will be circulated to Employer's personnel at site [Supervisor(s)/Executive(s)] and Contractor's personnel at site [Gang leader, supervisor(s) etc.] in their local language / language understood by gang.

THAT the Contractor has prepared minimum manpower deployment plan, activity wise as stated above, which is enclosed at **Annexure – 1B (SP)** for approval of Engineer In-charge/Project Manager.

4. THAT the Contractor shall ensure while executing works that they will deploy minimum 25% of their own experienced work force who are on the permanent roll of the company and balance 75% can be a suitable mix with the hired gangs / local workers / casual workers if required. The above balance 75% work force should be provided with at least 10 days training by the construction agencies at sites and shall be issued with a certificate. No worker shall be engaged without a valid certificate. Hired gang workers shall also follow safe working procedures and safety norms as is being followed by company's workmen. It should also be ensured by the Contractor that certified **workers** fitters who are climbing towers / doing stringing operations can be easily identifiable with a system like issue of Badge / Identification cards (ID cards) etc. Colour identification batches should be worn by the workers. Contractor has to ensure that inexperienced workers / unskilled workers should not be deployed for skilled job.
5. THAT the Contractor's Gang leader / Supervisor / Senior most member available at every construction site shall brief to each worker daily before start of work about safety requirement and warn about imminent dangers and precautions to be taken against the imminent dangers (Daily Safety Drill). This is to be ensured without fail by Contractor and maintain record of each gang about daily safety instructions issued to workers and put up to WBS&EDCL site In-charge for his review and record.
6. THAT the Contractor shall ensure that working Gangs at site should not be left at the discretion of their Gang Leaders who are generally hired and having little knowledge about safety. Gang leader should be experienced and well versed with the safe working procedures applicable for transmission line/ Sub Station works. In case gang is having Gang leader not on permanent roll of the company then additional Supervisor from company's own roll having thorough knowledge about the works would be deployed so as to percolate safety instructions upto the grass root level in healthy spirits. Contractor has to ensure close supervision while executing critical locations of transmission lines / sub stations and ensures that all safety instructions are in place and are being followed.

7. THAT the Contractor shall maintain in healthy and working condition all kind of Equipments / Machineries / Lifting tools / Lifting tackles / Lifting gears / All kind of Ropes including wire ropes / Polypropylene ropes etc. used for Lifting purpose during execution of the project and get them periodically examined and load tested for safe working load in accordance with relevant provisions and requirement of Building & other construction workers Regulation of Employment and Conditions of Services Act and Central Rule 1998 or latest, Factories Act 1948 or latest, Indian Electricity Act 2003 before start of the project. A register of such examinations and tests shall be properly maintained by the Contractor and will be promptly produced as and when desired by the Engineer In-charge/Project Manager or by the person authorised by him. The Contractor has to ensure to give special attention on the formation / condition of eye splices of wire rope slings as per requirement of IS 2762 Specification for wire rope slings and sling legs.

THAT the Contractor has prepared a list of all Lifting machines, lifting Tools / Lifting Tackles / Lifting Gears etc. / All types of ropes and Slings which are subject to safe working load is enclosed at **Annexure – 2 (SP)** for review and approval of Engineer In-charge/Project Manager.

8. THAT the Contractor has to procure sufficient quantity of Personal Protective Equipment (PPE) conforming to Indian / International standards and provide these equipment to every workman at site as per need and to the satisfaction of Engineer-in-charge/Project Manager of **WBSEDCL**. The Contractor's Site Supervisor/ Project Manager has to ensure that all workmen must use Personal Protective Equipment at site. The Contractor shall also ensure that Industrial Safety helmets are being used by all workmen at site irrespective of their working (at height or on ground). The Contractor shall further ensure use of safety shoes by all ground level workers and canvas shoes for all workers working at height, Rubber Gum Boots for workers working in rainy season and concreting job, Use of Twin Lanyard Full body Safety Harness with attachment of light weight such as aluminum alloy etc. and having features of automatic locking arrangement of snap hook, by all workers working at height for more than three meters and also for horizontal movement on tower shall be ensured by Contractor. The Contractor shall not use ordinary half body safety harness at site. The Contractor has to ensure use of Retractable type fall arrestors by workers for ascending / descending on suspension insulator string and other similar works etc., Use of Mobile fall arrestor for ascending / descending from tower by all workers. The Contractor has to provide cotton / leather hand gloves as per requirement, Electrical Resistance Hand gloves for operating electrical installations / switches, Face shield for protecting eyes while doing welding works and Dust masks to workers as per requirement. The Contractor will have to take action against the workers not using Personal Protective Equipment at site and those workers shall be asked to rest for that day and also their Salary be deducted for that day. **WBSEDCL** may issue warning letter to Project Manager of Contractor in violation of above norms.

THAT the Contractor shall prepare a detailed list of PPEs, activity wise, to commensurate with manpower deployed, which is enclosed at **Annexure – 3 (SP)** for review and approval of Engineer In-charge/Project Manager. It shall also be ensured that the sample of these equipment shall be got approved from **WBSEDCL** supervisory staff before being distributed to workers. The Contractor shall submit relevant test certificates as per IS / International Standard as applicable to PPEs used during execution of work. All the PPE's to be distributed to the workers shall be checked by **WBSEDCL** supervisory staff before its usage.

The Contractor also agrees for addition / modification to the list of PPE, if any, as advised by Engineer In-Charge/Project Manager.

9. THAT the Contractor shall procure, if required sufficient quantity of Earthing Equipment / Earthing Devices complying with requirements of relevant IEC standards (Generally IECs standards for Earthing Equipments / Earthing Devices are – 855, 1230, 1235 etc.) and to the satisfaction of Engineer In-Charge/ Project Manager and Contractor to ensure to maintain them in healthy condition.

THAT the Contractor has prepared / worked out minimum number of healthy Earthing Equipments with Earthing lead confirming to relevant IS / European standards per gang wise during stringing activity/as per requirement, which is enclosed herewith at **Annexure – 4 (SP)** for review and acceptance of Engineer In-Charge/ Project Manager prior to execution of work.

10. THAT the Contractor shall provide communication facilities i.e., Walkie – Talkie / Mobile Phone, Display of Flags / whistles for easy communication among workers during Tower erection / stringing activity, as per requirement.
11. THAT the Contractor undertakes to deploy qualified safety personnel responsible for safety as per requirements of Employer/Statutory Authorities.

THAT the Contractor employing more than 250 workmen whether temporary, casual, probationer, regular or permanent or on contract, shall employ at least one full time officer exclusively as qualified safety officer having diploma in safety to supervise safety aspects of the equipment and workmen who will coordinate with Engineer In-charge /Project Manager/Safety Coordinator of the Employer. In case of work being carried out through sub-Contractors the sub – Contractor's workmen / employees will also be considered as the Contractor's employees / workmen for the above purpose. If the number of workers are less than 250 then one qualified safety officer is to be deployed for each contract. He will report directly to his head of organization and not the Project Manager of Contractor He shall also not be assigned any other work except assigning the work of safety. The curriculum vitae of such person shall be got cleared from **WBSEDCL** Project Manager / Construction staff.

The name and address of such safety officers of Contractor will be promptly informed in writing to Engineer In-charge with a copy to safety officer - In-charge before start of work or immediately after any change of the incumbent is made during the currency of the contract. The list is enclosed at **Annexure – 5A (SP)**.

THAT the Contractor has also prepared a list including details of Explosive Operator (if required), Safety officer / Safety supervisor / nominated person for safety for each erection / stringing gang, list of personnel trained in First Aid Techniques as well as copy of organisation structure of the Contractor in regard to safety. The list is enclosed at **Annexure – 5B (SP)**.

12. The Project Manager shall have the right at his sole discretion to stop the work, if in his opinion the work is being carried out in such a way that it may cause accidents and endanger the safety of the persons and/or property, and/or equipment. In such cases, the Contractor shall be informed in writing about the nature of hazards and possible injury/accident and he shall comply to remove shortcomings promptly. The Contractor after stopping the specific work can, if felt necessary, appeal against the order of stoppage of work to the Project Manager within 3 days of such stoppage of work and decision of the Project Manager in this respect shall be conclusive and binding on the Contractor.
13. THAT, if, any Employer's Engineer/ supervisor at site observes that the Contractor is failing to provide safe working environment at site as per agreed Safety Plan / **WBSEDCL** Safety Rule/ Safety Instructions / Statutory safety requirement and creates hazardous conditions at site and there is possibility of an accident to workmen or workmen of the other Contractor or public or the work is being carried out in an un safe manner or he continues to work even after being instructed to stop the work by Engineer / Supervisor at site / RHQ / Corp. Centre, the Contractor shall be bound to pay a penalty of Rs. 10,000/- per incident per day till the instructions are complied with, and as certified by Engineer / Supervisor of Employer at site. The work will remain suspended and no activity will take place without compliance and obtaining clearance / certification of the Site Engineer / Supervisor of the Employer to start the work.
14. THAT, if the investigation committee of Employer observes any accident or the Engineer In-charge/Project Manager of the Employer based on the report of the Engineer/Supervisor of the Employer at site observes any failure on the Contractor's part to comply with safety requirement / safety rules/ safety standards/ safety instruction as prescribed by the Employer or as prescribed under the applicable law for the safety of the equipment, plant and personnel and the Contractor does not take adequate steps to prevent hazardous conditions which may cause injury to its own Contractor's employees or employee of any other Contractors or Employer or any other person at site or adjacent thereto, or public involvement because of the

Contractor's negligence of safety norms, the Contractor shall be liable to pay a compensation of Rs. 10,00,000/- (Rupees Ten Lakh only) per person affected causing death and Rs. 1,00,000/- (Rupees One Lakh only) per person for serious injuries / 25% or more permanent disability to the Employer for further disbursement to the deceased family/ Injured persons. The permanent disability has the same meaning as indicated in Workmen's Compensation Act 1923 or latest. The above stipulations is in addition to all other compensation payable to sufferer as per workmen compensation Act / Rules

THAT as per the Employer's instructions, the Contractor agrees that this amount shall be deducted from their running bill(s) immediately after the accident, That the Contractor understands that this amount shall be over and above the compensation amount liable to be paid as per the Workmen's Compensation Act /other statutory requirement/ provisions of the Bidding Documents.

15. THAT the Contractor shall submit Near-Miss-Accident report along with action plan for avoidance such incidence /accidents to Engineer – In-charge/ Project Manager. Contractor shall also submit Monthly Safety Activities report to Engineer – In-charge/ Project Manager and copy of the Monthly Safety Activities report also to be sent to Safety In-charge at RHQ of the Employer for his review record and instructions.
16. THAT the Contractor is submitting a copy of Safety Policy/ Safety Documents of its Company which is enclosed at **Annexure – 6 (SP)** and ensure that the safety Policy and safety documents are implemented in healthy spirit.
17. THAT the Contractor shall make available of First Aid Box [Contents of which shall be as per Building & other construction workers (Regulation of Employment and Conditions of Services Act and Central Rule 1998 or latest / **WBSEDCL Guidelines**)] to the satisfaction of Engineer In-Charge/ Project Manager with each gang at site and not at camp and ensures that trained persons in First Aid Techniques with each gang before execution of work.
18. THAT the Contractor shall submit an 'Emergency Preparedness Plan' for different incidences i.e. Fall from height, Electrocution, Sun Stroke, Collapse of pit, Collapse of Tower, Snake bite, Fire in camp / Store, Flood, Storm, Earthquake, Militancy etc. while carrying out different activities under execution i.e. foundation works including civil works, erection, stringing (as applicable), testing & commissioning, disposal of materials at site / store etc. which is enclosed at **Annexure – 7 (SP)** for approval of the Engineer In-Charge/ Project Manager before start of work.
19. THAT the Contractor shall organise Safety Training Programs on Safety, Health and Environment and for safe execution of different activities of works i.e.foundation works including civil works, erection, stringing (as applicable), testing

&commissioning, disposal of materials at site / store etc. for their own employees including sub-Contractor workers on regular basis.

The Contractor, therefore, submits copy of the module of training program, enclosed at **Annexure – 9 (SP)**, to Engineer In-charge/Project Manager for its acceptance and approval and records maintained.

20. THAT the Contractor shall conduct safety audit, as per Safety Audit Check Lists enclosed at **Annexure – 8 (SP)**, by his Safety Officer(s) every month during construction of Transmission Lines / Sub Stations / any other work and copy of the safety audit report will be forwarded to the Employer's Engineer In-charge / Site In-charge/Project Manager for his comments and feedback. During safety audit, healthiness of all Personal Protective Equipment (PPEs) shall be checked individually by safety officer of Contractor and issue a certificate of its healthiness or rejection of faulty PPEs and Contractor has to ensure that all faulty PPEs and all faulty lifting tools and tackles should be destroyed in the presence of **WBSEDCL** construction staff. Contractor has to ensure that each gang be safety audited at least once in two months. During safety audit by the Contractor, Safety officer's feedback from **WBSEDCL** concerned shall be taken and recorded. The Employer's site officials shall also conduct safety audit at their own from time to time when construction activities are under progress. Apart from above, the Employer may also conduct surveillance safety audits. The Employer may take action against the person / persons as deemed fit under various statutory acts/provisions under the Contract for any violation of safety norms / safety standards.
21. THAT the Contractor shall develop and display Safety Posters of construction activity at site and also at camp where workers are generally residing.
22. THAT the Contractor shall ensure to provide potable and safe drinking water for workers at site / at camp.
23. THAT the Contractor shall do health checkup of all workers from competent agencies and reports will be submitted to Engineer In-Charge within fifteen (15) days of health checkup of workers as per statutory requirement.
24. THAT the Contractor shall submit information along with documentary evidences regarding compliance to various statutory requirements as applicable which are enclosed at **Annexure – 10A (SP)**.

The Contractor shall also submit details of Insurance Policies taken by the Contractor for insurance coverage against accident for all employees are enclosed at **Annexure – 10B (SP)**.

25. THAT a checklist in respect of aforesaid enclosures along with the Contractor's remarks, wherever required, is attached as **Annexure – Check List** herewith.

THE CONTRACTOR shall incorporate modifications/changes in this 'Safety Plan' necessitated on the basis of review/comments of the Engineer In-Charge/Project Manager within fourteen (14) days of receipt of review/comments and on final approval of the Engineer In-Charge/Project Manager of this 'Safety Plan', the Contractor shall execute the works under the Contract as per approved 'Safety Plan'. Further, the Contractor has also noted that the first progressive payment towards Services Contract shall be made on submission of 'Safety Plan' along with all requisite documents and approval of the same by the Engineer In-Charge/Project Manager.

IN WITNESS WHEREOF, the Contractor has hereunto set its hand through its authorised representative under the common seal of the Company, the day, month and year first above mentioned.

For and on behalf of

M/s.....

WITNESS

- |                   |                           |
|-------------------|---------------------------|
| 1. Signature..... | Signature.....            |
| Name.....         | Name.....                 |
| Address.....      | Address.....              |
| 2. Signature..... | Authorised representative |
| Name.....         | (Common Seal)             |
| Address.....      | (In case of Company)      |

**Note:**

All the annexure referred to in this "Safety Plan" are required to be enclosed by the Contractor as per the attached "Check List"



1. Safety Plan is to be executed by the authorised person and (i) in case of contracting Company under common seal of the Company or (ii) having the power of attorney issued under common seal of the company with authority to execute such contract documents etc., (iii) In case of (ii), the original Power of Attorney if it is specifically for this Contract or a Photostat copy of the Power of Attorney if it is General Power of Attorney and such documents should be attached to this Safety Plan.
2. For all safety monitoring/ documentation, Engineer In-charge / Regional In-charge of safety at RHQ will be the nodal Officers for communication.

**CHECK LIST FOR SEFETY PLAN**

<b>S. N.</b>	<b>Details of Enclosure</b>	<b>Status of Submission of information/ documents</b>	<b>Remarks</b>
1.	<p><b>Annexure – 1A (SP)</b></p> <p>Safe work procedure for each activity i.e. foundation works including civil works, erection, stringing (as applicable), testing &amp; commissioning, disposal of materials at site / store etc. to be executed at site.</p>	Yes/No	
2.	<p><b>Annexure – 1B (SP)</b></p> <p>Manpower deployment plan, activity wise foundation works including civil works, erection, stringing (as applicable), testing &amp; commissioning, disposal of materials at site / store etc.</p>	Yes/No	
3.	<p><b>Annexure – 2 (SP)</b></p> <p>List of Lifting Machines i.e. Crane, Hoist, Triffor, Chain Pulley Blocks etc. and Lifting Tools and Tackles i.e. D shackle, Pulleys, come along clamps, wire rope slings etc. and all types of ropes i.e. Wire ropes, Poly propylene Rope etc. used for lifting purposes along with test certificates.</p>	Yes/No	
4.	<p><b>Annexure – 3 (SP)</b></p> <p>List of Personal Protective Equipment (PPE), activity wise including the following along with test certificate of each as applicable:</p> <hr/> <p>A. Industrial Safety Helmet to all workmen at site. (EN 397 / IS 2925) with chin strap and back stay arrangement.</p> <p>B. Safety shoes without steel toe to all ground level workers and canvas shoes for workers working on tower.</p>	Yes/No	

S. N.	Details of Enclosure	Status of Submission of information/ documents	Remarks
	<p>C. Rubber Gum Boot to workers working in rainy season / concreting job.</p> <p>D. Twin lanyard Full Body Safety harness with shock absorber and leg strap arrangement for all workers working at height for more than three meters. Safety Harness should be with attachments of light weight such as of aluminum alloy etc. and having a feature of automatic locking arrangement of snap hook and comply with EN 361 / IS 3521 standards.</p> <p>E. Mobile fall arrestors for safety of workers during their ascending / descending from tower / on tower. EN 353 -2 (Guided type fall arresters on a flexible anchorage line.)</p> <p>F. Retractable type fall arrestor (EN360: 2002) for ascending / descending on suspension insulator string etc.</p> <p>G. Providing of good quality cotton hand gloves / leather hand gloves for workers engaged in handling of tower parts or as per requirement at site.</p> <p>H. Electrical Resistance hand gloves to workers for handling electrical equipment / Electrical connections. IS : 4770</p> <p>I. Dust masks to workers handling cement as per requirement.</p> <p>J. Face shield for welder and Grinders. IS : 1179 / IS : 2553</p> <p>K. Other PPEs, if any, as per requirement etc.</p>		
5.	<p><b>Annexure – 4 (SP)</b></p> <p>List of Earthing Equipment / Earthing devices with Earthing lead conforming to IECs for earthing equipment are – (855, 1230, 1235 etc.) gang wise for stringing activity/as per requirement</p>	Yes/No	
6.	<p><b>Annexure – 5A (SP)</b></p>	Yes/No	

S. N.	Details of Enclosure	Status of Submission of information/ documents	Remarks
	List of Qualified Safety Officer(s) along with their contact details		
7.	<p><b>Annexure – 5B (SP)</b></p> <p>Details of Explosive Operator (if required), Safety officer / Safety supervisor for every erection / stringing gang, any other person nominated for safety, list of personnel trained in First Aid as well as brief information about safety set up by the Contractor along with copy of organisation of the Contractor in regard to safety</p>	Yes/No	
8.	<p><b>Annexure – 6 (SP)</b></p> <p>Copy of Safety Policy/ Safety Document of the Contractor's company</p>	Yes/No	
9.	<p><b>Annexure – 7 (SP)</b></p> <p>'Emergency Preparedness Plan' for different incidences i.e. Fall from height, Electrocutation, Sun Stroke, Collapse of pit, Collapse of Tower, Snake bite, Fire in camp / Store, Flood, Storm, Earthquake, Militancy etc. while carrying out different activities under execution i.e. foundation works including civil works, erection, stringing (as applicable), testing &amp; commissioning, disposal of materials at site / store etc.</p>	Yes/No	
10.	<p><b>Annexure – 8 (SP)</b></p> <p>Safety Audit Check Lists ( Formats to be enclosed)</p>	Yes/No	
11.	<p><b>Annexure – 9 (SP)</b></p>	Yes/No	

S. N.	Details of Enclosure	Status of Submission of information/ documents	Remarks
	Copy of the module of Safety Training Programs on Safety, Health and Environment, safe execution of different activities of works for Contractor's own employees on regular basis and sub-Contractor employees.		
12.	<p><b>Annexure – 10A (SP)</b></p> <p>Information along with documentary evidences in regard to the Contractor's compliance to various statutory requirements including the following:</p>		
(i)	<p>Electricity Act 2003</p> <p>_____</p> <p>–</p> <p><i>[Name of Documentary evidence in support of compliance]</i></p>	Yes/No	
(ii)	<p>Factories Act 1948 or latest</p> <p>_____</p> <p>–</p> <p><i>[Name of Documentary evidence in support of compliance]</i></p>	Yes/No	
(iii)	<p>Building &amp; other construction workers (Regulation of Employment and Conditions of Services Act and Central Act 1996 or latest) and Welfare Cess Act 1996 or latest with Rules.</p> <p>_____</p> <p>–</p> <p><i>[Name of Documentary evidence in support of compliance]</i></p>	Yes/No	
(iv)	<p>Workmen Compensation Act 1923 or latest and Rules.</p>	Yes/No	

S. N.	Details of Enclosure	Status of Submission of information/ documents	Remarks
	<hr/> <p>– [Name of Documentary evidence in support of compliance]</p>		
(v)	<p>Public Insurance Liabilities Act 1991 or latest and Rules.</p> <hr/> <p>– [Name of Documentary evidence in support of compliance]</p>	Yes/No	
(vi)	<p>Indian Explosive Act 1948 or latest and Rules.</p> <hr/> <p>– [Name of Documentary evidence in support of compliance]</p>	Yes/No	
(vii)	<p>Indian Petroleum Act 1934 or latest and Rules.</p> <hr/> <p>– [Name of Documentary evidence in support of compliance]</p>	Yes/No	
(viii)	<p>License under the contract Labour (Regulation &amp; Abolition) Act 1970 or latest and Rules.</p> <hr/> <p>– [Name of Documentary evidence in support of compliance]</p>	Yes/No	
(ix)	<p>Indian Electricity Rule 2003 and amendments if any, from time to time.</p>	Yes/No	

S. N.	Details of Enclosure	Status of Submission of information/ documents	Remarks
	<hr/> <p>– [Name of Documentary evidence in support of compliance]</p>		
(x)	<p>The Environment (Protection) Act 1986 or latest and Rules.</p> <hr/> <p>– [Name of Documentary evidence in support of compliance]</p>	Yes/No	
(xi)	<p>Child Labour (Prohibition &amp; Regulation) Act 1986 or latest.</p> <hr/> <p>– [Name of Documentary evidence in support of compliance]</p>	Yes/No	
(xii)	<p>National Building Code of India 2005 or latest (NBC 2005).</p> <hr/> <p>– [Name of Documentary evidence in support of compliance]</p>	Yes/No	
(xiii)	<p>Indian standards for construction of Low/ Medium/ High/ Extra High Voltage Transmission Line</p> <hr/> <p>–</p>	Yes/No	

S. N.	Details of Enclosure	Status of Submission of information/ documents	Remarks
	<i>[Name of Documentary evidence in support of compliance]</i>		
(iv)	Any other statutory requirement(s) <i>[please specify]</i>  — <i>[Name of Documentary evidence in support of compliance]</i>	Yes/No	
13.	<b>Annexure – 10B (SP)</b>  Details of Insurance Policies along with documentary evidences taken by the Contractor for the insurance coverage against accident for all employees as below:		
(i)	Under Workmen Compensation Act 1923 or latest and Rules.  — <i>[Name of Documentary evidence in support of insurance taken]</i>	Yes/No	
(ii)	Public Insurance Liabilities Act 1991 or latest  — <i>[Name of Documentary evidence in support of insurance taken]</i>	Yes/No	
(iii)	Any Other Insurance Policies  — <i>[Name of Documentary evidence in support of insurance taken]</i>	Yes/No	



---

## 19. FORM OF JOINT DEED OF UNDERTAKING BY THE SUB- CONTRACTOR ALONGWITH THE CONTRACTOR

THIS DEED OF UNDERTAKING executed this ..... day of .....  
Two Thousand and ..... by M/s. ...., a Company incorporated  
under the laws of ..... and having its Registered Office at  
..... (hereinafter called the “**Sub-Contractor**” which  
expression shall include its successors, executors and permitted assigns), and M/s.  
....., a Company incorporated under the laws of ..... having  
its Registered Office at ..... (hereinafter called the “**Bidder**”/”**Contractor**”  
which expression shall include its successors, executors and permitted assigns) in favour  
of **WBSEDCL** a Company incorporated under the Companies Act of 1956/2013 (with  
amendment from time to time) having its registered office at **Vidyut Bhawan, 2<sup>nd</sup> Floor,  
Block-DJ, Sector-II, Bidhannagar, Kolkata-700091** (hereinafter called the “**Employer**”  
which expression shall include its successors, executors and permitted assigns)

WHEREAS the “**Employer**” invited Bid as per its Specification  
No.....for **RDSS works of ..... including installation of Sub-  
stations, lines, bays, DTs and providing service connections etc.**

AND WHEREAS Clause No. ...., Section ....., of ....., Part...  
forming part of the Bid Documents inter-alia stipulates that the Bidder and/or Sub-  
Contractor must fulfill the Qualifying Requirements and be jointly and severally bound and  
responsible for the quality and timely execution of **RDSS works** in the event the Bid  
submitted by the Bidder is accepted by the Employer resulting in a Contract.

AND WHEREAS the Bidder has submitted its Bid to the Employer vide Proposal No.  
..... dated ..... based on tie-up with the **Sub-Contractor** for execution of  
aforesaid **RDSS works**.

NOW THEREFORE THIS UNDERTAKING WITNESSETH as under:

- 1.0 In consideration of the award of Contract by the Employer to the Bidder (hereinafter referred to as the “**Contract**”) we, the **Sub-Contractor** and the Contractor do hereby declare that we shall be jointly and severally bound unto the **WBSEDCL**, for **execution of RDSS works** in accordance with the Contract Specifications.
- 2.0 Without in any way affecting the generality and total responsibility in terms of this Deed of Undertaking, the **Sub-Contractor** hereby agrees to depute their representatives from time to time to the Employer’s Project site as mutually considered necessary by the Employer, Contractor and the **Sub-Contractor** to ensure proper quality, manufacture, testing and supply on FOR destination delivery at site basis and successful performance of **RDSS works** in accordance with Contract Specifications. Further, if the Employer suffers any loss or damage on account of non-performance of the material fully meeting the performance

guaranteed as per Bid Specification in terms of the contract. We the **Sub-Contractor** and the Contractor jointly and severally undertake to pay such loss or damages to the Employer on its demand without any demur.

- 3.0 This Deed of Undertaking shall be construed and interpreted in accordance with the laws of India and the Courts in Kolkata (Headquarter of Employer) shall have exclusive jurisdiction in all matters arising under the Undertaking.
- 4.0 We, the Bidder/Contractor and **Sub-Contractor** agree that this Undertaking shall be irrevocable and shall form an integral part of the Contract and further agree that this Undertaking shall continue to be enforceable till the Employer discharges it. It shall become operative from the effective date of Contract.

IN WITNESS WHEREOF the **Sub-Contractor** and/or the Contractor have through their Authorised Representatives executed these presents and affixed Common seals of their respective Companies, on the day, month and year first above mentioned.

WITNESS

(For **Sub-Contractor**)

Signature .....

(Signature of the authorized representative)

Name .....

Office Address .....

Name .....

Common Seal of Company  
.....

WITNESS

(For Bidder)

Signature .....

(Signature of the authorized representative)

Name .....

Office Address .....

Name .....

Common Seal of Company  
.....

**Note:**

1. For the purpose of executing the Deed of Joint Undertaking, the non-judicial stamp papers of appropriate value shall be purchased in the name of executant(s).
2. The Undertaking shall be signed on all the pages by the authorised representatives of each of the partners and should invariably be witnessed.
3. This Deed of Joint Undertaking duly attested by Notary Public of the place(s) of the respective executant(s), shall be submitted along with the bid.
4. In case the bid is submitted by a Sole/ Bidder/ Lead Joint Venture(JV) Member of two or more firms as partners, then the Joint deed of undertaking shall be modified accordingly.

**20. FORM OF CERTIFICATE OF FINANCIAL PARAMETERS FOR QR****(as per clause ref. no. 2 of Section 2 of Part 1)****(Rupees in Lakhs)**

S. No.	Financial parameters	2020-21	2019-20	2018-19	2017-18	2016-17
<b>1.</b>	<b>Net Worth</b>					
a)	Paid up Capital					
b)	Free Reserves and Surplus*					
c)	Misc. expenses to the extent not written off					
	<b>Net Worth (a+b-c)</b>					
<b>2.</b>	<b>Annual Turnover **</b>					
<b>3.</b>	<b>Liquid Asset (Total Current Asset – Inventories)</b>					

\* Free Reserve and Surplus should be Exclusive of Revaluation Reserve, written back of Depreciation Provision and Amalgamation.

\*\* Annual total Income/ turnover as incorporated in the Profit and Loss Account excluding non-recurring income, i.e., sale of fixed asset etc.

It is certified that all the figures are based on audited accounts read with auditors report and Notes to Accounts etc.

Date

Certified By

Place

(Chartered Accountants)

Membership No.

Seal

## 21. PROFORMA OF INDEMNITY BOND TO BE EXECUTED BY THE CONTRACTOR FOR THE COVERAGE AGAINST LATENT DEFECT

(To be submitted in NJ Stamp Paper of value Rupees 100/-)

BY THIS BOND I Shri .....on behalf of M/S  
 .....Designation.....  
 residing at.....hereinafter called OBLIGOR firmly bound unto WBSEDCL a  
 company incorporated under Company Act 1956 having Registered office at .....herein  
 after referred as OBLIGEE or its executor , administrator or assigns, for which payment to be truly  
 and faithfully made . i/we as OBLIGOR bind ourselves and all our heirs , executor , administrator  
 or assigns ,by these present.

Sealed with our seal.....this .....day of .....

WHEREAS THE said OBLIGOR has entered into a contract with WBSEDCL /OBLIGEE vide  
 LOA No.....Dated.....work in accordance with term , specification and  
 conditions as describe in LOA / Contract which have been already agreed upon and signed by said  
 the OBLIGOR and WBSEDCL/OBLIDGE.

NOW THE CONDITION of the above written bond or obligation in such that ,the said OBLIGOR  
 shall duty and punctually as per terms of aforesaid LOA/Contract complete the contract within the  
 stipulated period as per agreed terms and conditions.

The OBLIGOR shall ensure and warrant the material will be held , new unused and in accordance  
 with contractual stipulations free from defects and workmanship for a period of 12(twelve) calendar  
 month commencing immediately after his satisfactory commissioning of the materials /equipment  
 relating erection and other related activities as supplied.

At the end of the guarantee period ,the OBLIGOR liability ceases except for latent defects and  
 OBLIGOR'S liability as mentioned in clause 19 of the GCC of 'Bid Document' shall remain till  
 the end of five years from the date of completion of Guarantee period and the OBLIGOR shall  
 cover for latent defect as substantiated by technical committee of WBSEDCL commonly known as  
 Expert Committee.

In case if default on the part of OBLIGOR to perform its part of the aforesaid undertaking then it  
 shall make good or indemnify WBSEDCL for any damage/loss sustain by it , to the extent  
 substantiated by the technical committee /Expert Committee of WBSEDCL.

IN WITNESS WHEREOF we have to set out respective hands and seal this  
 .....day of .....202.....

-----  
 (Authorised Signature of OBLIGOR)  
 (with Name and Designation)  
 Company seal

Sign sealed and Delivered in Presence of :

.....  
 Signature with Name, Designation & Address

.....  
 Signature with Name, Designation & Address

## **ADDITIONAL CLAUSE: SECTION – 6**

### **CLAUSE: 14 GENERAL INSTRUCTIONS ON ENVIRONMENT MANAGENT PLAN (EMP)**

1. The Contractor shall comply with all applicable national, state, and local environmental, health and safety (labor) laws and regulations.
2. The Contractor shall comply with the EMP as per FORM – 6.
3. The Contractor shall comply with the ADB’s Safeguard Policy Statement (2009), the International Finance Corporation’s Environmental Health and Safety General Guidelines and the guidelines on Electric Power Transmission and Distribution, and the International Labor Organization’s Safety and Health in Construction guidelines.
4. The Contractor shall carry out all the requirements set forth in the environment safeguards framework attached here as FORM -6 and assigned to the Contractor and allocate the staffing and budget required to ensure that such requirements are met. More particularly, the Contractor will undertake site visits and consultations and complete screening forms and consultation proforma using the templates included in the FORM-6 for each distribution line and submit to the Employer for approval before starting any works on that distribution line including site establishment and site clearance work.
5. The Contractor shall implement the mitigation measures and carry out the monitoring requirements set forth in the FORM -6 and the project-level environmental management plan (EMP) attached here as FORM -6 allocate the staff and budget required to ensure that such requirements are met. The Contractor shall ensure mitigation measures are implemented at all construction sites as well as at any workers’ camps or accommodation provided by them or their subcontractors. During project implementation the EMP will need to be updated to reflect any site-specific mitigation measures and monitoring requirements for each distribution line which the Contractor will be required to comply with. The definitive version of the EMP to be complied with by the Contractor will be disclosed on the ADB website.
6. The Contractor shall not commence any “*Physical Works*” on a distribution line including site establishment, tree or vegetation clearance until (i) written confirmation is received from the Employer that all project financier clearances have been obtained, (ii) the Contractor has undertaken and reported to the Employer on the findings of all applicable pre-construction environmental survey work and baseline environmental monitoring requirements, including completion of the screening forms and consultation proforma; (iii) the Contractor has incorporated all the applicable requirements of the EMP into their detailed designs; (iv) written confirmation is received from the Employer that the distribution line has been approved following submission of the completed screening forms and consultation proforma, (v) all required environment, health and safety (labor) permits or licenses including CTE for any construction plant have been obtained, and (vi) it has submitted all sub-plans required by the EMP and received written confirmation from the Employer of their approval.
7. The Contractor will be required to implement any corrective actions set out in safeguard monitoring reports that the Employer will prepare from time to time to report on implementation of the program to ADB. The Contractor shall cover the cost of corrective action required in response to non-compliance with the contract clauses, the definitive version of the EMP, or property damage caused by the Contractor, subcontractors and third parties employed by them.
8. The Contractor shall appoint at least (i) one appropriately qualified and experienced, dedicated Environment Officer, (ii) one appropriately qualified and experienced, dedicated Health and Safety Officer, (iii) one appropriately qualified and experienced, dedicated social and community liaison officer who will also act as the Grievance Focal Point for the Contractor; and (iv) sufficient appropriately qualified and experienced, dedicated environment, health and safety site supervisors to oversee all active distribution line works. The supervisors will be based on-site to supervise EMP implementation for the duration of all “*Physical Works*” undertaken.

9. The Contractor shall employ suitably qualified and experienced third-party monitoring experts to carry out surveys, field tests and laboratory analysis required by the definitive version of the EMP in respect of environmental monitoring for ecology, air quality, noise, surface water and groundwater quality, and soil contamination, whichever is applicable.
10. The Contractor shall ensure that all its construction staff, as well as formal and informal subcontractors involved, understand their responsibilities to implement the EMP with appropriate training provided including construction-site EHS inductions, emergency procedure drills, monthly refresher trainings, and daily toolbox talks. The Contractor shall ensure all construction staff, including the staff of subcontractors, have attended the necessary specialized, task-specific training and are medically fit to perform their role.
11. The Contractor shall establish an operational system for managing and monitoring environmental, health and safety impacts and risks, progress with implementation, and compliance to the environment safeguards framework requirements. The Contractor's management and staff will attend meetings to be convened by the Employer for EMP. The Contractor will submit monthly reports on progress and compliance to the Employer documenting the mitigation measures and monitoring activities carried out, issues encountered including statistics and details of all near misses and accidents, grievances received, and follow-up actions that were taken (or will be taken) to correct any issues.
12. In case of (i) an unanticipated impact not considered in the EMP, including changes to the scope or design, or (ii) non-compliance, the Contractor will inform the "Employer" in writing and implement corrective actions agreed. In case of a health and safety incident or chance find it will inform the "Employer" within 24 hours with details of the incident and the corrective action being taken.
13. The Contractor will ensure no polychlorinated biphenyl (PCB) and no asbestos containing materials are used in construction. Transformers purchased shall be accompanied by a letter from the manufacturer they are guaranteed PCB free against each Serial No. of Transformers.
14. Sand and stone will only be obtained from existing approved quarries with valid EC, CTE and CTO and sources of water will have abstraction license. Records will be kept of the volume of all the materials used and their source.
15. The Contractor will ensure no forced or child labor or persons under 18 are employed on the project.
16. The contractor shall take all measures and precautions necessary to ensure the health, safety and welfare of all persons entitled to be on the site and will ensure that works are carried out in a safe and efficient manner. Such precautions shall include those that, in the opinion of the Employer, are reasonable to prevent unauthorized entry into the site and to protect members of the public from any activities under the control of the contractor.
17. The Contractor shall provide and maintain a suitably equipped and staffed first aid station. First aid equipment and free access for workers to a qualified nurse and/or doctor must be provided. Ambulance for moving injured persons to the nearest hospital must also be provided in ready to move condition. First-aid kits shall contain an adequate supply of in-date sterilized dressings and bandages with other necessary first aid equipment as per national health and safety (labor) laws and regulations and the EMP requirements.
18. The Contractor shall provide and maintain all necessary fire protection and firefighting facilities during the construction of the Works and shall comply with all national and state fire safety requirements. These facilities must include in-date, serviced, portable fire extinguishers suitable for fighting the potential hazards on the construction site.
19. Detailed design to ensure operational noise and EMF standard/guideline levels as specified in the definitive version of the EMP will be complied with. If noise levels cannot be met through siting alone, incorporate acoustic barrier(s) designed to international good practice around either the noise source and/or substation boundary to attenuate noise to level such that standards/guideline levels will be met.
20. Detailed design will ensure all ground mounted transformers are mounted on an impermeable plinth with spill containment bund of 110% capacity.



21. On individual items of electrical equipment provide written and visual warning signs to include the ISO 7010 "Hazard Type: Electrical Symbol" warning of risk of electrocution with an internal fence for high-risk equipment.
22. The Contractor will not undertake any works that could trigger the ADB environment category A (e.g., components/activities with significant adverse environmental impacts that are irreversible, diverse, or unprecedented).
23. The Contractor must not undertake any works that result in the significant conversion or degradation of natural habitat as defined by the ADB SPS 2009 or which are within a critical habitat as defined by the project financier ADB SPS 2009.
24. The Contractor will not undertake any works in National Parks, Wildlife Sanctuaries, bird sanctuaries, tiger reserve, elephant reserve, community reserve, conservation reserve, national World Heritage sites, Ramsar sites, reserve/protected forest areas, biodiversity heritage sites, or, notified wetlands. ABC conversion of existing distribution line that involves no new poles being constructed (except that required to bear additional load within the existing alignment, no diverted or new route) and underground cabling following existing power line or road rights of way can be allowed inside the eco sensitive zones (taken as 10km when the eco sensitive zone has not yet been gazetted) provided that (i) based on biodiversity study adverse impacts and risks to biodiversity, especially birds, primates, and elephants, can be avoided, by virtue of location and/or design, (ii) critical habitat as defined by the ADB SPS 2009 will not be impacted, and (iii) the works are in accordance with the legal requirements for eco sensitive zones and forest/wildlife department have been consulted and have provided their written agreement.
25. The Contractor will ensure no new overhead lines or new poles outside of existing route alignments will be constructed in important biodiversity areas, key biodiversity areas, or wildlife/tiger/elephant corridors. Conversion of lines to ABC, including new poles to bear the excess weight, using existing route alignments, and underground cables will only be permitted if based on biodiversity study (i) adverse impacts and risk to biodiversity, especially birds, primates, and elephants, can be avoided by virtue of location and/or design, and (ii) critical habitat as defined by the ADB SPS 2009 will not be impacted.
26. The Contractor may adopt "bird sensitive design" for overhead distribution lines following Gol and international good practice guidelines.
27. The Contractor must not undertake any work that would result in significant damage to physical cultural resources or require physical cultural resources to be removed from their current location must be excluded.
28. The Contractor will not undertake any works in historical/cultural areas including ASI monuments or their protected/regulated zones, cultural World Heritage Sites and their buffer zones.
29. The Contractor must ensure all safety clearances per Government of India requirements are met by new and upgraded distribution lines. No new feeders will be constructed across school compounds or buildings; conversion of existing lines to ABC will only be permitted if school compounds are not crossed, or minor rerouting takes place to avoid them.
30. Bidders shall comply with the Grievance redress mechanism as mentioned in the EMP-ANNEXURE-I hereunder.
31. Bidders shall also consider and cause no harm to the important installations, Birds and Animals during their project construction work. The detailed list is provided as "West Bengal- District Sensitivity Matrix" under the enclosed EMP-ANNEXURE-II.

## **EMP-ANNEXURE-I**

### **GRIEVANCE REDRESS MECHANISM**

1. GRM can be an effective tool for early identification and resolution of complaints on subprojects. Under the project, it is required that an efficient consultation and grievance redress mechanism be established to assist affected persons to resolve queries and complaints, if any, in a timely manner. The guidelines on GRM will be applied at project and subproject level to assure that adequate resources are made available for the project GRM to function effectively.

2. ADB's Safeguard Policy Statement (2009) requires the establishment of a responsive, readily accessible and culturally appropriate GRM capable of receiving and facilitating the resolution of affected persons' concerns and grievances about the physical, social and economic impacts of the project. The GRM aims to (i) reduce conflict, risk of undue delay and complication in Project implementation; (ii) improve the quality of Project activities and outputs; (iii) ensure that the rights of affected persons are respected; (iv) help identify and respond to unintended impacts of Project on individuals; and (v) maximize participation, support and benefits to local communities. The proposed GRM for the Project is presented in Table 14 and Figure 8.

3. The proposed GRM, which will handle both environmental and social grievances, includes grievance redress committees (GRCs) to be setup by WBSEDCL (EA) at respective district Project Offices and Project Head Quarter to provide the means for the effective resolution of complaints and issues on each subproject. The GRCs will be convened as necessary by WBSEDCL or DISCOM grievance focal point (GFP) and, in addition, include a representative of the affected person, a representative of women groups, the relevant Village Panchayet Pradhan (headman/woman)/Chairperson of concerned Municipality, the relevant Project Manager, a nominated divisional forest officer or equivalent for environment safeguards grievances or nominated district revenue officer as nodal officer for social safeguards grievances, and, the designated GFP of the contractor dealing with the environmental or social safeguards as applicable. The GRCs will meet as and when a major grievance (i.e. grievance which cannot be resolved at contractor or DISCOM level) arises.

4. The fundamental objectives of the GRM are:

- i. To reach mutually agreed solutions satisfactory to both, the Project and the affected persons, and to resolve any Project-related grievance locally, in consultation with the aggrieved parties;
- ii. To facilitate the smooth implementation of the EMPs and resolution of compensations and prevent delay in subproject implementation;
- iii. To democratize the development process at the local level, while maintaining transparency as well as to establish accountability to the affected people;
- iv. To facilitate an effective dialogue and open communication between the Project and affected persons; and
- v. To have clear definition of roles and responsibilities of the various parties involved in consideration and resolution of grievances.

**Chart View of Grievance Handling Process**

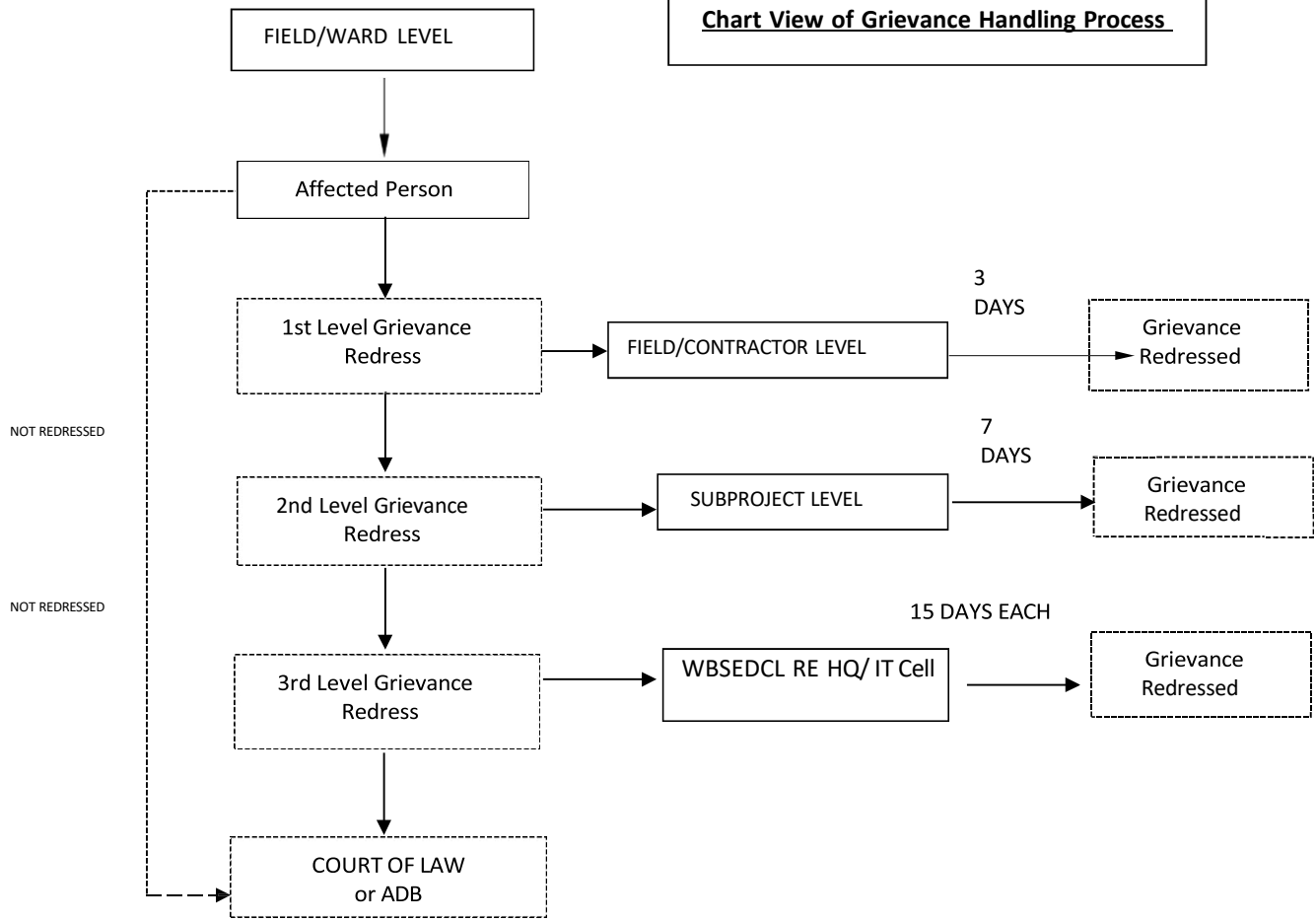

### Grievance Handling Process

Level	Name of Level	Description	Time frame <sup>14</sup>
1	Field level (by contractor and DISCOM field officials)	<p>One Grievance Focal Person (GFP) will be assigned by each contractor and the WBSEDCL in order to receive and handle grievances. Complaints can be registered by contractor or directly to Project Offices of WBSEDCL.</p> <p>Contractor's GFP should receive the complaint (written or verbal) and provide acknowledgement letter to the complainer within 3 days after receipt of the complaint.</p> <p>Contractor's GFP should maintain data of Grievance Logbook and submit/update all necessary data related to the registered grievances to the WBSEDCL's GFP on a weekly basis.</p> <p>Upon resolution the Contractor's GFP should convey the solution to the affected person and seek their concurrence (written or verbal) that it is acceptable to them.</p> <p>If the grievance cannot be solved within 3 working days, then Contractor's GFP should submit</p>	3 working days
Level	Name of Level	Description	Time frame <sup>14</sup>

		information to the next level (WBSEDCL GFP at subproject level) and provide updated information to the complainant regarding the grievance resolution process being followed.	
2	MFF subproject level (DISCOM GFP; District Project Office)	<p>The WBSEDCL GFP (District Project Office ) for each subproject should review the grievance with the support of the environment and social safeguards officers and resolve it within 7 working days.</p> <p>If the case is complex and requires investigation (experts' opinion) expertise or confirmations from the state bodies, the resolution period can be extended up to 15 calendar days.</p> <p>Upon resolution the WBSEDCL's GFP should convey the solution to the affected person and seek their concurrence (written or verbal) that it is acceptable to them.</p> <p>If the grievance cannot be resolved still, or the complaining party is not agreed with the offered solution, then the WBSEDCL GFP should submit information to the next level (WBSEDCL HQ GRC) and provide updated information to the complainant regarding the grievance resolution process being followed.</p> <p>WBSEDCLs GFP should maintain data of Grievance Logbook and submit/update all necessary data related to the registered grievances to WBSEDCL Project Offices on a monthly basis.</p>	7 working days
3a	Implementing Agency level Grievance Redress Committee (DISCOM HQ)	<p>The WBSEDCL GFP will request the WBSEDCL HQ GRC to review the grievance and resolve it within 15 calendar days. If the grievance is found invalid (after investigation of the GRC) a written response should be given to the complaining party explaining the reasons for its rejection. Otherwise a written response explaining the resolution should be provided to the complaining party and their concurrence (written or verbal) sought by the WBSEDCL GFP to confirm that it is acceptable to them.</p> <p>If the grievance cannot be resolved still, or the complaining party is not agreed with the offered solution, then the WBSEDCL GFP should submit information to the next level (WBSEDCL GRC) and provide updated information to the complainant regarding the grievance resolution process being followed.</p>	15 working days

3b	Executing Agency level Grievance Redress Committee (WBSEDCL)	WBSEDCL GFP will request WBSEDCL GRC to review the grievance and resolve it within 15 calendar days. If the grievance is found invalid (after investigation of the GRC) a written response should be given to the complaining party explaining the reasons for its rejection. Otherwise a written response explaining the resolution should be provided to the complaining party and their concurrence (written or verbal) sought by the DISCOM GFP to confirm that it is acceptable to them	15 working days
4	Court or INRM	If the affected person is still not satisfied with the GRC decision, the affected person can submit his/her complaint to the appropriate court of law in India for its resolution. The GRM does not impede access to the country's judicial or administrative remedies, so the project affected persons can file the case to the court of law regardless of the GRM stage and process. In addition, the affected person may raise the concern with ADB Operations Department through INRM for resolution. Project-affected people can also submit complaints to ADB's Accountability Mechanism. The Accountability Mechanism provides an independent forum and process whereby people adversely affected by ADB-financed projects can voice, and seek a resolution of their problems, as well as report alleged violations of ADB's operational policies and procedures.	Depends on nature of the complaint

5. *Receiving grievances:* All the received grievances should be registered by the GFP of contractor and WBSEDCL. Submitting grievances and registration should be a straightforward process, and the affected persons should be able to submit their grievances and questions directly or through a third party. This process requires availability of (i) responsible person to receive and register the complaints (GFP); (ii) multiple points (at field, DISCOM office) for receiving grievances; (iii) procedure for acknowledging the receipt (registered and signed) and informing the complaining party about the expected timeframe for the review and resolution; and (iv) grievance logbook about the complaints and their status.

6. The complaining party should be able to submit grievance in person, by phone call, email, letter or fax, to the GFP assigned by the contractor or Project Offices of WBSEDCL. Receipt of grievance lodged in person or via phone should be acknowledged immediately by a paper issued by the GFP or other persons who received the grievance. Any documentation relating to submitting and feeding back on grievances should be in Hindi (and other appropriate) local language.

7. All the grievances, however minor, and regardless of its nature and eligibility, should be recorded in a grievance logbook in detail. Upon receipt of grievances, the contractor's GFP in coordination with the WBSEDCL GFP, referring to Project Offices of WBSEDCL should sort them into the following categories to define if the complaint is eligible for the Project established GRM. The procedure should establish clear parameters (if complaint is caused by the Project activities) for qualifying grievance as eligible or ineligible for the Project established GRM. The following types of grievances are not eligible for resolution by the Project established GRM:

- Grievances that are not related to the Project, or
- Grievances that should be reviewed by separate, more appropriate procedures (e.g. issues of fraud and corruption).

8. *Feedback provision:* After receiving grievance, the GFP (or other responsible person) should:

- Provide acknowledgement of the grievance receipt, with response/ recommendations to complainant;





# **WBSEDCL West Bengal State Electricity Distribution Co. Ltd.**

## **PUBLIC CONSULTATION NOTICE**

The West Bengal State Electricity Distribution Company Limited (WBSEDCL) hosting a meeting to discuss Conversion of Existing Feeders to Aerial Bunched Cable and Separation of Feeders work proposed under Revamped Reforms Based and Results Linked, Distribution Sector Scheme(RDSS). The details of meeting are given below.

**Date:** -----

**Venue:** -----

**Time:** -----

**Discussion Point:**

- Address by WBSEDCL officials
- Information about project and proposed work in the area/village
- Information on key impacts, mitigation measures and recommendations from safeguards assessments
- An opportunity to present your views and concerns on the proposed work

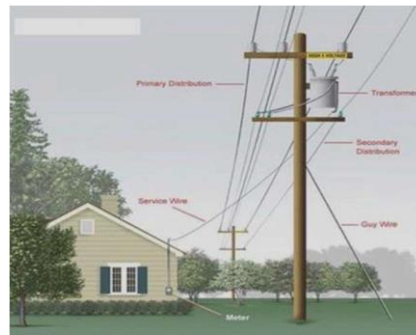
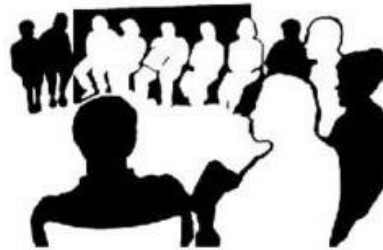

The meeting is open to the Public and will provide a chance for the community to come together and receive up to date information regarding the proposed work to be carried out under this Project and raise their issues, if any.

*For Further information or queries, please contact WBSEDCL at below place and number.*

*Office Address: .....*

*Phone Contact No: .....*



**EMP-ANNEXURE-II**

**WEST BENGAL – District Sensitivity Matrix**

District	District HQ	Subdivision	Km of Project DL	Number and area of Protected Areas	Number and area of KBA (IBA)	Elephant reserve / corridor	Tiger reserve / corridor	Number of National protected monuments	Number of State protected monuments	Population (subdivision totals)	Population density (population/sqkm (subdistrict))	% Illiterate (subdivision %)	Tribal area	% Urban (built up)	% agricultural	% forest	% water	Elevation range	Other notable features
Malda	English Bazar	Malda Sadar			<p>KBA/IBA - Farakka Barrage and adjoining area (20 sqkm)</p> <p>IBA - Naya Bandh Wetland Complex (4 sqkm)</p> <p>KBA/IBA - Gogabil Pakshi Vihar, Baghar Beel and Baldia Chaur (Located in adjacent Bihar State within 1km buffer from Malda dist. boundary)</p> <p>Not reported in IBAT: Udhuwa Lake Bird Sanctuary in adjacent</p>			<p>21 ASI sites</p> <ol style="list-style-type: none"> <li>Adina Mosque</li> <li>Baisgazi Wall</li> <li>Baroduary Masjid</li> <li>Bhita of Chand Sagar</li> <li>Chamkati masjid</li> <li>Chika Masjid</li> <li>Dakhil Darwaza</li> <li>Firoz Minar</li> <li>Gumti Gateway</li> <li>Gunmant Mosque</li> <li>Kotwali Darwaja</li> <li>Lottan Masjid</li> <li>Lukachuri Gateway</li> <li>Qadam rasul Mosque</li> <li>Tomb of Fateh Khan</li> </ol>	<ol style="list-style-type: none"> <li>Jami mosque in Old Malda municipality</li> <li>Ruins of the fortified city of Pandua</li> <li>Ruins of Pathan palace at Adian</li> <li>Ancient ruins at Ratnagarh at Wari</li> <li>Ancient ruin site at Gagjibannpur</li> </ol>	274627	1109	46%	1.89%	13.58%	55%	1.5%	7%	40-159m	<p>Shares a 165.5 km international border with Bangladesh.</p> <p>Prone to flooding and river bank erosion.</p> <p>Low-lying basin, it is prone to flood. Major River - Ganga, Mahananda, Kalindi</p>

District	District HQ	Subdivision	Km of Project DL	Number and area of Protected Areas	Number and area of KBA (IBA)	Elephant reserve / corridor	Tiger reserve / corridor	Number of National protected monuments	Number of State protected monuments	Population (subdivision totals)	Population density (population/sqkm (subdistrict))	% Illiterate (subdivision %)	Tribal area	% Urban (built up)	% agricultural	% forest	% water	Elevation range	Other notable features
					Jharkhand State with 1km buffer			16. Tantipara Masjid 17. Two Tombs of Tantipara Masjid 18. Two Stone Pillars 19. Tower Nimasarai 20. Eklankhi Mausoleum 21. Qutub Shahi Masjid											
		Chanchal			-			-	-	1338379	1154	42%	0.42%	11%					
<b>Mursidabad</b>	Baharampur	Sadar						9 ASI sites  1. Tomb of Azimunnisha Begum 2. Residency Cemetery/Station Burial ground 3. Tomb of Mir Madan 4. Dutch Cemetery 5. Old English Cemetery or Old Residency Burial Ground 6. Devil's Mound * Raja Karna's Palace	1. Tomb of Nawab Sharfaraz Khan at Naginabagh 2. Temple of Gangeswar Siva at Baranagar 3. Siva temple at Yugwara	1725525	1443	31%	1%	19.85%	60%	0.55%	10%	30-100m	125.3km Bangladesh Border Main river Bhagirathi and bordered by Padma River Key environmental issue in Murshidabad is natural river bank erosion. Murshidabad district in West Bengal has lost a lot of land to the river Ganga, as thousands of people are rendered homeless

District	District HQ	Subdivision	Km of Project DL	Number and area of Protected Areas	Number and area of KBA (IBA)	Elephant reserve / corridor	Tiger reserve / corridor	Number of National protected monuments	Number of State protected monuments	Population (subdivision totals)	Population density (population/sqkm (subdistrict))	% Illiterate (subdivision %)	Tribal area	% Urban (built up)	% agricultural	% forest	% water	Elevation range	Other notable features
								7. Katra Masjid 8. Jahan Kosha Cannon 9. Hazarduari Palace & Imambara	4. Ravratna temple at Sibarambati										♣ Soil erosion in the right bank of the river Ganga has rendered many people homeless.
		Jangipur			IBA- Farakka Barrage and adjoining area (20 sqkm)			1 ASI site 1. Kheraul Mosque		1972308	1796	40%	1.43%	44%					
		Kandi						1 ASI site 1. Mound known as Barkona Duel Mound		1155645	963	35%	0.8%	6.79%					
		Lalbagh						10 ASI sites 1. Bhavaniswar Mandir 2. Char Bangla group of four Siva Mandirs 3. South Gate, Kella Nezamat 4. Imambara, Kella Nezamat 5. White Mosque, Kella Nezamat 6. Yellow Mosque, Kella Nezamat 7. Tripolia Gate, Kella Nizammat	1. The house, temples and ruins associated with memory of Jagat Sett's house at Mahimpur	1253886	1230	33%	2.6%	7.64%					

District	District HQ	Subdivision	Km of Project DL	Number and area of Protected Areas	Number and area of KBA (IBA)	Elephant reserve / corridor	Tiger reserve / corridor	Number of National protected monuments	Number of State protected monuments	Population (subdivision totals)	Population density (population/sqkm (subdistrict))	% Illiterate (subdivision %)	Tribal area	% Urban (built up)	% agricultural	% forest	% water	Elevation range	Other notable features
								8. Tomb of Alivardi Khan & Seraj-ud-daullah 9. Tomb of Sujauddin											
		Domkal						-		996443	1189	34.5 %	0.51 %	2.45 %					
<b>Birbhum</b>	Suri	Suri Sadar						2 ASI sites 1. Temple & Rasmancha/Damodar Temple 2. Dharmaraj Temple	1. Motichur mosque at Rjanagar 2. Temple of Dewanji and its contiguous shrines at Hetampur 3. Temple of Chandra Nath Siva at Hetampur 4. Siva temple at	1121871	629	29%	8.8 %	3.43 %	73%	4%	3%	33-94m	Mayurakshi & Ajoy River  Asian elephants from nearby Jharkhand state migrate into the district in search of food and sometime in attraction of Mahua flower ( <i>Madhuca longifolia</i> ). Northern plains gray langur ( <i>Semnopithecus entellus</i> ) found partridges, green pigeons, and various water fowls. Few migratory birds are also found near Bolpur. Common birds of deltaic Bengal are mixed up in this

District	District HQ	Subdivision	Km of Project DL	Number and area of Protected Areas	Number and area of KBA (IBA)	Elephant reserve / corridor	Tiger reserve / corridor	Number of National protected monuments	Number of State protected monuments	Population (subdivision totals)	Population density (population/sqkm (subdistrict))	% Illiterate (subdivision %)	Tribal area	% Urban (built up)	% agricultural	% forest	% water	Elevation range	Other notable features
									5. Panchra Siva temple at Rasa 6. Visnu temple at Hatsarandi 7. Kali temple at Patharkunchi										district with birds of wooded hill, doyel, indian robin, drongo, hawk cuckoo, koel, sun bird, Indian roller (nilkantha), parrot and babblers are found in abundance.
		Bolpur		Ballabhpur Wildlife Sanctuary (2.021 sqkm)  (not reported in IBAT)  ESZ: 100m buffer from WLS boundary vide Gazatte notification dated 25 Sept 2019 <sup>1</sup> .				3 ASI sites  1. Temple of Radha Binod/Joydeb 2. Two Mounds 3. Temple of Basuli and the mound together with 14 other temples near them containing the Linga images of Shiva	1. Octagonal Siva temple at Supu 2. Temple of Kali at Itanda 3. Navaratna temple at Brahma ndidhi 4. Temple of Gouranga at	872027	735	27%	8.8 %	3.44 %					

<sup>1</sup> <https://moef.gov.in/wp-content/uploads/2018/12/ballavpur.pdf>



District	District HQ	Subdivision	Km of Project DL	Number and area of Protected Areas	Number and area of KBA (IBA)	Elephant reserve / corridor	Tiger reserve / corridor	Number of National protected monuments	Number of State protected monuments	Population (subdivision totals)	Population density (population/sqkm (subdistrict))	% Illiterate (subdivision %)	Tribal area	% Urban (built up)	% agricultural	% forest	% water	Elevation range	Other notable features
				local and winter visitors; Others: Birbhum Forest Division				-	1. Malleswar Siva temple at Mallarpur 2. Bhandiswara Siva temple at Bhandiswar  Local/ Regional importance: 1. Tarapitah Temple	1508506	958	31%	4.8%	3.38%					
<b>Purba Burdwan</b>	Burdwan	Burdwan Sadar (North)		Ramnabagan Wildlife Sanctuary (0.15 sqkm)  (Not reported by IBAT)  ESZ: 100m buffer from WLS boundary			In November 2021, around 50 elephants came within 5 km of east Burdwan town	1. Rudreswar Temple 2. Tomb of Baharam Sakka, Sher Afghan and Nawab Qutabuddin 3. Panduk Rajar Dhipi	1. Excavated monument at Goswamikhandada 2. Bijoy - Toran at	1586623	810	28.3%	9%	26%	20%	23%	15%	30-104m	Damodar River, Flood prone

District	District HQ	Subdivision	Km of Project DL	Number and area of Protected Areas	Number and area of KBA (IBA)	Elephant reserve / corridor	Tiger reserve / corridor	Number of National protected monuments	Number of State protected monuments	Population (subdivision totals)	Population density (population/sqkm (subdistrict))	% Illiterate (subdivision %)	Tribal area	% Urban (built up)	% agricultural	% forest	% water	Elevation range	Other notable features
				vide Gazatte notification dated 19 Sept 2018 <sup>2</sup>  Regulated: Erection of electrical and communication towers and laying of cables and other infrastructure - Regulated under applicable laws (underground cabling may be promoted)  Notable species: Cheetal ( <i>Axis axis</i> ), Northern plains gray langur ( <i>Semnopithecus entellus</i> ), Black buck				4. Ancient mound, Bharatpur	Burdwan town										
		Burdwan Sadar (South)						1. Jain brick temple known as Sat-Deul	1. Abandoned Gopal temple	1198155	850	23%	10.2%	4.46%					

<sup>2</sup> <https://westbengalforest.gov.in/upload/draft/ramnabagan.pdf>



District	District HQ	Subdivision	Km of Project DL	Number and area of Protected Areas	Number and area of KBA (IBA)	Elephant reserve / corridor	Tiger reserve / corridor	Number of National protected monuments	Number of State protected monuments	Population (subdivision totals)	Population density (population/sqkm (subdistrict))	% Illiterate (subdivision %)	Tribal area	% Urban (built up)	% agricultural	% forest	% water	Elevation range	Other notable features
									<ul style="list-style-type: none"> <li>at Amdpur</li> <li>2. Siva temple at Honpas – Kamarpura</li> <li>3. Temple of Kashina th Siva at Ajhapur</li> <li>4. Temple of Madan Gopal at Kulingram</li> </ul>										
		Katwa						-	<ul style="list-style-type: none"> <li>1. Radha Gobunda temple at Jagadanandapur</li> <li>2. Three Siva temple at Sribati</li> </ul>	963022	900	31.7 %	1.2 %	11.6 %					

District	District HQ	Subdivision	Km of Project DL	Number and area of Protected Areas	Number and area of KBA (IBA)	Elephant reserve / corridor	Tiger reserve / corridor	Number of National protected monuments	Number of State protected monuments	Population (subdivision totals)	Population density (population/sqkm (subdistrict))	% Illiterate (subdivision %)	Tribal area	% Urban (built up)	% agricultural	% forest	% water	Elevation range	Other notable features
									3. Badsahi or Hussain Shai mosque at Nutanh at Hussain Shah mosque at Kulutia										
		Kalna						1. Two ancient temples (joined together) 2. Group of temples (12 nos. temples sub ASI sites) as follows: (i) Bijoy Vaidyanath Temple (ii) Giri Gobardhan Temple (iii) Gopalji Temple, (iv) Jaleswar Temple (v) Krishna Chandraji Temple	1. Majlish Saheb or Id-Baqrid mosque at Kalna town 2. Panchratna brick temple at Baidyapur	1097732	1100	25.4 %	7.6 %	13%					

District	District HQ	Subdivision	Km of Project DL	Number and area of Protected Areas	Number and area of KBA (IBA)	Elephant reserve / corridor	Tiger reserve / corridor	Number of National protected monuments	Number of State protected monuments	Population (subdivision totals)	Population density (population/sqkm (subdistrict))	% Illiterate (subdivision %)	Tribal area	% Urban (built up)	% agricultural	% forest	% water	Elevation range	Other notable features	
								(vi) Lalji Temple, (vii) Nava-Kailasha Temple  (viii) Pancharatna Temple (ix) Pratapeswar Siva Temple in Rajbari compound (x) Rameswar Temple,  (xi) Ratneswar Temple  (xii) Rupeswar Temple												
Paschim Burdwan	Asansol	Asansol			KBA/IBA - Reservoirs of Chota Nagpur Plateau (Part in subdivision and part in Jharkhand State)			1. Group of four Ancient Temples 2. Stone Temple, Garui		1672659	2000	27%	9%	83.33%	20%	38%		45-75m	Coal Mining & Industrial area  Durgapur: Notified as Critically polluted area by CPCB	
		Durgapur		Other: Durgapur Forest Division			1. Temple of Ichai Ghosh 2. Ancient Site, Nadiha		1209372	1600	24.8%	7%	79.22%						The District Gazetter, Bardhaman, depicted that, the mammalian carnivore of the district comprises of leopard (Panthera pardus), wolf (Canis lupus), hyaena (Hyaena hyaena), jackal	

District	District HQ	Subdivision	Km of Project DL	Number and area of Protected Areas	Number and area of KBA (IBA)	Elephant reserve / corridor	Tiger reserve / corridor	Number of National protected monuments	Number of State protected monuments	Population (subdivision totals)	Population density (population/sqkm (subdistrict))	% Illiterate (subdivision %)	Tribal area	% Urban (built up)	% agricultural	% forest	% water	Elevation range	Other notable features
																			(Canis aureus) and other smaller species, but hyaenas are not so common. Tigers (Panthera tigris) were formerly common in the district, especially in the jungles of the Asansol subdivision adjoining the Jharkhand, but have now a days entirely disappeared from this province of Paschim Bardhaman. Wolves are in frequently found and are mostly met with in the jungles north of Kanksa. Wild pigs (Sus scrofa) are numerous throughout the district and monkeys (Cercopithecidae sp.)
<b>Nadia</b>	Krishna nagar	Krishnan agar Sadar		Bethuadahari Wildlife Sanctuary				1. Mound known as	1. Temple of Raghob	2186503	1316	31.5 %	2.6 %	20.8 %	18.8 %	3.5 %	1.3 %	5.5-28.8m	One of the major environmental issues of the

District	District HQ	Subdivision	Km of Project DL	Number and area of Protected Areas	Number and area of KBA (IBA)	Elephant reserve / corridor	Tiger reserve / corridor	Number of National protected monuments	Number of State protected monuments	Population (subdivision totals)	Population density (population/sqkm (subdistrict))	% Illiterate (subdivision %)	Tribal area	% Urban (built up)	% agricultural	% forest	% water	Elevation range	Other notable features
				(0.66686 sqkm)  (Not reported in IBAT)  ESZ notification not found  Notable species:  Spotted deer, Jackal, Bengal fox, Porcupine, Common Langur, Parakeets, Indian Cuckoo, Barbets and other smaller birds and pythons				1. Bamanpukur Mound or Fort 2. Ruins of Fort	eswar Sivat Dignagar										district is presence of Arsenic in ground water
		Ranaghat						-	1. Temple of Shyamchand at Santipur town	1432761	1600	22.4 %	2.6 %	41.7 %					
		Kalyani						1. Temple, Palpara		891563	1693	19%	5.1 %	76.7 %					

District	District HQ	Subdivision	Km of Project DL	Number and area of Protected Areas	Number and area of KBA (IBA)	Elephant reserve / corridor	Tiger reserve / corridor	Number of National protected monuments	Number of State protected monuments	Population (subdivision totals)	Population density (population/sqkm (subdistrict))	% Illiterate (subdivision %)	Tribal area	% Urban (built up)	% agricultural	% forest	% water	Elevation range	Other notable features
		Tehatta						-		796245	924	33%	1.90%	2.85%					
Hoogly	Chinsura	Chinsura						<ol style="list-style-type: none"> <li>1. Haneswari and Vasudev temples</li> <li>2. Dutch Cemetery together with all tombs &amp; monuments contained therein</li> <li>3. Dutch Memorial monument of Susan Anna Maria</li> <li>4. Group of temples known as Brindaban Chandra's Math</li> <li>5. Mounds, Mahanad</li> <li>6. MInar, Pandua</li> <li>7. Mosque, Pandua</li> <li>8. Mosque &amp; Tombs, Satgaon</li> <li>9. Shrine and Mosque known as Dargah of</li> </ol>	<ol style="list-style-type: none"> <li>1. Chandi temple at Deulpara</li> <li>2. Siva temple at Bakharpur</li> <li>3. Temple of Sri Sri Nandad ulal Jew at Gurap</li> <li>4. The mast of a Portuguese ship at bandal</li> </ol>	1657518	1400	22.8%	10.8%	0.55%	6.34%	12.87%	2.27%	11-17m	<p>Hoogly &amp; Damodar River, Bank erosion prone</p> <p>Almost in every year the district is affected by flood in major areas of Khanakul - II, Khanakul - I, Arambagh Sub-division &amp; Tarakeswar &amp; Balagarh Blocks under Chandernagore &amp; Sadar Sub-division. Specially Khanakul - I &amp; Khanakul – II remain water logged for long days due to heavy rainfall as well as due to discharge of DVC water through Damodar, Mundeswari, Darakeswar rivers only for their low topography.</p>

District	District HQ	Subdivision	Km of Project DL	Number and area of Protected Areas	Number and area of KBA (IBA)	Elephant reserve / corridor	Tiger reserve / corridor	Number of National protected monuments	Number of State protected monuments	Population (subdivision totals)	Population density (population/sqkm (subdistrict))	% Illiterate (subdivision %)	Tribal area	% Urban (built up)	% agricultural	% forest	% water	Elevation range	Other notable features
								Zafar Khan Gazi, Tribeni											
		Chandan nagar						1. Duplex Palace (Institute de Chandan Nagar)	1. Raj Rajeswar temple at Dwarahatta	1127176	2200	19%	4.4%	41.5%					
		Serampore						1. i) Danish Cemetery ii) All ancient structures, all tombs stone monument remains and inscriptions within the area enclosed by the said walls	1. Henry martin's Pagoda at Serampore 2. Temple of Gour Chandra and Krishna chandra at Chatra 3. Radha Govinda temple at Satpur 4. Siva temple at Hariram pur 5. Raj Rajeswar	1469849	3500	67%	1.65%	73.1%					

District	District HQ	Subdivision	Km of Project DL	Number and area of Protected Areas	Number and area of KBA (IBA)	Elephant reserve / corridor	Tiger reserve / corridor	Number of National protected monuments	Number of State protected monuments	Population (subdivision totals)	Population density (population/sqkm (subdistrict))	% Illiterate (subdivision %)	Tribal area	% Urban (built up)	% agricultural	% forest	% water	Elevation range	Other notable features	
									temple at Kotalpur											
		Arambagh						-	<ol style="list-style-type: none"> <li>1. Jorbangla temple at Parul</li> <li>2. Raghunandan temple at Parul</li> <li>3. Jorbangla temple of Durga with Navaratna tower at Bali dewanganj</li> <li>4. Mosque at Village Bajua</li> <li>5. Kanakeswar Shiva temple, Byra Kanpur</li> </ol>	1264602	1200	21%	2.2%	5.23%						



## FORM- 6

### Environmental Management Plan (EMP)

**IND: Development of Distribution Infrastructure for Loss Reduction at Hoogly, Burdwan East, Burdwan West, Birbhum, Nadia, Murshidabad and Malda District of West Bengal under Revamped Reforms Based and Results linked Distribution Sector Scheme (RDSS) – ADB Funded.**

This Environmental Management Plan (EMP) for Bidding Document has been prepared for Turnkey Contract Packages of proposed West Bengal 'RDSS Scheme' Project. The scope of project included Development of Distribution Infrastructure for Loss Reduction at Hooghly, Burdwan East, Burdwan West, Birbhum, Nadia, Murshidabad and Malda Districts of West Bengal under Revamped Reforms Based and Results Linked, Distribution Sector Scheme.

The EMP is applicable to all subprojects under the Project includes mitigation measures and monitoring requirements presented in the matrix form. This EMP Matrix will form part of the contract document together with General Environment, Health & Safety (EHS) Conditions of Contract (CoC) for all contractors.

This EMP shall be updated based on detailed design and it will be the basis for the contractor to prepare site specific Environmental Management Plan (EMP).

#### Environmental Management Plan Matrix

Project Activity	Potential Environmental Impact	Mitigation Action	Parameters to be Monitored	Standards/ Measurement/ Frequency	Institutional Responsibility	Implementation Schedule
<b>PLANNING &amp; DESIGN / PRE-CONSTRUCTION PHASE</b>						
<b>A Physical Resources</b>						
Interference with drainage patterns/Irrigation channels	Temporary flooding hazards/loss of agricultural production	Pole by pole survey (network survey) of all existing bare conductor lines that will be replaced with AB Cabling.	Survey data and route maps	Review of survey data / line route maps - Once	Contractor subject to review by WBSEDCL / PMA (Project Management Agency)	Survey and design
Interference with national roads and railway lines	Traffic congestion. Possible damage to road / railway	Use of underground cabling for national road / railway crossings using Horizontal Directional Drilling (HDD) method as per Technical Specifications.	Permits / clearances/ approvals from road / railway authorities and their guidelines.	Technical Specifications and guidelines issued by road and railway	Contractor subject to review by WBSEDCL /	Survey and design / pre-construction

Project Activity	Potential Environmental Impact	Mitigation Action	Parameters to be Monitored	Standards/ Measurement/ Frequency	Institutional Responsibility	Implementation Schedule
	infrastructure causing public inconvenience	Obtain necessary permits / clearances/ approvals from road / railway authorities. Follow guidelines issued by the authorities for detailed design.		authorities - Once	PMA.	
<b>B Environment Resources</b>						
Location of poles and other facilities	Impact to the existing environment	Based on network survey data and line route maps, if new LT/HT lines are passing through forest areas, natural flow paths, important ecological habitats or close proximity to water bodies obtain approvals / permits from concerned authorities or propose alternate routes avoiding these areas in case of new LT/HT lines.	Survey data and route maps Conditions of permits / approvals and clearances	Review of survey data / line route maps by WBSEDCL/ PMA – Once	Contractor subject to review by WBSEDCL / PMA	Survey and design
	Impact to the existing environment	Obtain necessary permits, approvals and clearances from concerned Authorities such as local authorities, forest dept. etc. once the line routes are finalized as above. (if required)	Conditions of permits / approvals and clearances	Consultation with authorities. Review of survey data / line route maps by WBSEDCL/ PMA – Once	Contractor subject to review by WBSEDCL / PMA	Survey and design
	Impact on water bodies / land/ residences	If pole by pole survey indicates location of poles and distribution transformers inside or close proximity to water bodies propose alternate pole locations or re-routing of lines. Also consider crossing of water bodies through special arrangements (long span lines).  If illegal encroachments are noted within right of way (RoW) of the existing lines that disturb proposed conductor replacements with necessary clearances, consult WBSEDCL to remove such obstacles through appropriate actions or re-route lines as necessary.  If new LT/ HT lines are passing through private lands consider shifting lines to	Survey data and route maps	Review of survey data / line route maps by WBSEDCL/ PMA – Once	Contractor subject to review by WBSEDCL / PMA	Survey and design

Project Activity	Potential Environmental Impact	Mitigation Action	Parameters to be Monitored	Standards/ Measurement/ Frequency	Institutional Responsibility	Implementation Schedule
		boundary locations or obtain permission from owners to continue the line in the same manner.				
	Noise generation exposure to noise, Nuisance to neighbouring properties	Maintain specified clearances (designs) for distribution lines to houses and buildings. Supply of distribution transformers with specified maximum noise levels as per specifications	Proximity of lines / distribution transformers to buildings. Noise level measurement of distribution transformers as per type testing	Statutory clearances as per IE rules / Transformer noise level as per NEMA Publication No. TR-1 - Once	Contractor subject to review / testing by WBSEDCL / PMA	Survey and design / supply of equipment
	Impact on water bodies / land/ residences	Line routes and facilities shall be planned to avoid resettlements (no resettlements permitted for this project). Avoid location of poles inside or close proximity to water bodies and if necessary crossing of water bodies through special arrangements (long span lines). Avoid location of facilities inside private lands (unless permission is obtained from owners in exceptional cases).	Survey data and route maps	Consultation with local authorities and landowners / Review of survey data / line route maps by WBSEDCL/ PMA – Once	Contractor subject to review by WBSDCL / PMA	Survey and design
Impact on visual aesthetics / loss of original landscape beauty	Impact to the existing environment	New lines and distribution poles to be sited to minimize visual impacts and the amount of visual clutter as far as possible given the nature of the project.  Consult individual households where a new pole location is directly in front of private property prior to finalizing detailed design.	Survey data and route maps  Compliance with national laws and regulations	Consultation with local authorities and landowners / Review of survey data / line route maps by WBSEDCL/ PMA – Once	Contractor subject to review by WBSDCL / PMA	Survey and design
Impact on construction waste, Health and safety	Pollution risk and generation of construction wastes	Prepare pollution prevention plan (PPP) and construction waste management plan (CWMP) for solid and hazardous waste management (if any) in accordance with national regulations and the IFC's General EHS Guidelines (2007).  For all construction works undertake	Compliance with national laws and regulations	Consultation with local authorities / Review of survey data / line route maps by WBSEDCL/ PMA – Once	Contractor subject to review by WBSDCL / PMA	Survey and design

Project Activity	Potential Environmental Impact	Mitigation Action	Parameters to be Monitored	Standards/ Measurement/ Frequency	Institutional Responsibility	Implementation Schedule
		risk assessment and prepare H&S plan in accordance with the IFC EHS General Guidelines on OHS for approval by DISCOM, considering occupational and community H&S and including adherence to electrical safety standards and emergency preparedness and response plan with communication systems and protocols to report an emergency situation.				
<b>C Ecological Resources</b>						
Encroachment into sensitive ecological areas	Loss of sensitive ecological values/ damage to endangered species	Based on network survey if new LT/HT lines encroach into ecologically sensitive areas obtain necessary approvals from concerned authorities or re-route lines as necessary.	Floral and faunal habitats loss	Enumeration of flora and fauna at site-Once	Contractor subject to review by WBSEDCL / PMA	Survey and design
Cutting and Trimming of Trees	Loss of trees along the Right of Way (RoW)	Minimize tree cutting and trimming requirements for any new line routes proposed.	Tree-loss	Tree cutting statistics provided by the Contractor-Once	Contractor subject to review by DISCOMS / PMA	Survey and design
<b>D Human Environment</b>						
Involuntary resettlement or land acquisition	Loss of habitats and structures	Avoid loss of habitats and structures during construction as no resettlement plan is permitted	Survey data and line route maps	-	Contractor with the approval of WBSEDCL	Pre-construction phase

<b>Project Activity</b>	<b>Potential Environmental Impact</b>	<b>Mitigation Action</b>	<b>Parameters to be Monitored</b>	<b>Standards/ Measurement/ Frequency</b>	<b>Institutional Responsibility</b>	<b>Implementation Schedule</b>
Encroachment into farmland	Loss of agricultural productivity	If power lines cross directly through private farmland; shift such lines towards boundaries.  Farmers to be compensated for any permanent loss of cash crop trees that need to be trimmed or removed.	Survey data and line route maps	Appropriate compensation - Once	Contractor with the approval of WBSEDCL	Pre-construction phase
Proximity of lines to houses and buildings	Safety risks to residents	Maintain vertical and horizontal statutory clearances for power lines to buildings as per technical specifications. If necessary re-route the proposed lines.	Survey data and line route maps	Technical Specifications, IE rules, CEA guidelines Review of survey data and line route maps - Once	Contractor subject to review by WBSEDCL / PMA	Survey and design
Power line construction planning	Safety risks to people due to excessive sags / breakage of conductors / collapse of lines	Prepare sag-tension charts for stringing of AB cables at different ambient temperatures to control maximum sag and maximum tension at different ambient temperatures.  Ensure stays / struts are placed at required locations to support poles to ensure stability of lines.	Technical specifications and construction designs	Technical specifications, CEA guidelines  Review of line design by WBSEDCL / PMA - Once	Contractor subject to review by WBSEDCL / PMA	Detailed design

Project Activity	Potential Environmental Impact	Mitigation Action	Parameters to be Monitored	Standards/ Measurement/ Frequency	Institutional Responsibility	Implementation Schedule
Construction of power lines and facilities at heritage sites	Loss of aesthetic value	<p>As far as possible power lines and facilities shall be constructed not harming aesthetics of archaeological, historical, cultural, and religious heritage sites. Typically lines and distribution transformers shall be located away from such sites. Where necessary ABC or underground cables shall be used instead of bare conductor lines.</p> <p>Distribution transformers if required inside the site may be installed within enclosures or buildings.</p> <p>Consultations with heritage site authorities shall be carried out to plan and design facilities in compliance to their requirements.</p>	Survey data and line route maps	Detailed designs - Once	Contractor subject to review by WBSEDCL / PMA	Survey and design
Interference with other utilities and traffic due to design and layout of Project equipment	Safety risks to WBSEDCL	<p>Obtain necessary clearances consistent with the requirements of Government of India and Government of West Bengal from other utilities that could be affected by the Project (electric, water, sewerage, telecommunications, road, rail etc.)</p> <p>Contractor to prepare for DISCOM approval traffic management plan in consultation with relevant local authorities to ensure proper execution of traffic controls including where temporary blockage of one lane of the road during installation is required for health and safety purposes that highly visible guides, advance warning signs or flag persons are in place to direct pedestrian and vehicular traffic.</p>	Survey data and line route maps	<p>100% of clearances obtained before commencement of works. Traffic management plan approved before commencement of works. No unresolved grievances from local community</p> <p>Compliance with national laws and regulations</p>	Contractor subject to review by WBSEDCL / PMA Review and approval of traffic management plan Assist with review and approval of traffic management plan	Survey and design

Project Activity	Potential Environmental Impact	Mitigation Action	Parameters to be Monitored	Standards/ Measurement/ Frequency	Institutional Responsibility	Implementation Schedule
Location of workers camp and materials storage areas could adversely affect residential areas and sensitive receptors (schools, hospitals/clinics )		If required, laydown and storage areas, temporary worker camps, etc. to be located at least 25m from waterbodies, 50m from springs and groundwater wells, and 50m from sensitive receptors (houses, schools, clinics, temples, etc.) however noisy and dusty activities such as concrete batching, hot mix, construction workers overnight accommodation etc. to be located at least 200m away from any sensitive receptors. Local communities to be consulted when selecting sites for project facilities prior to finalization.	Related facilities located sufficient distance from nearest receptors  No unresolved grievances from local community  Compliance with national laws and regulations	Part of detailed design and pre-construction phase	Contractor subject to review by WBSEDCL / PMA	Pre-Construction phase

**CONSTRUCTION PHASE**

**A Physical Resources**

Erection of new poles and stays	Soil erosion	Implement measures to prevent possibility of soil erosion due to surface run off. Measures include immediate backfilling and compaction / stabilisation of excavated soils from pole pits and disposal of surplus soil as per approved procedure.	Soil erosion	Visual inspection of site – Once per each site upon completion of work	Contractor subject to monitoring by WBSEDCL / PMA	Construction phase
	Water contamination	Measures shall be taken to prevent water quality degradation in downstream water bodies from construction sites. Construction work should be carefully designed to prevent obstruction or destruction to natural drainage. Surplus soil / materials / waste and debris during construction shall be disposed as approved and shall not be left where it may be carried by water to downstream flood plains, dams, lagoons or other water bodies. Immediate backfilling and compaction / stabilisation of soil during construction.	Water contamination	Visual inspection of site – Once per each site upon completion of work	Contractor subject to monitoring by WBSEDCL / PMA	Construction phase

<b>Project Activity</b>	<b>Potential Environmental Impact</b>	<b>Mitigation Action</b>	<b>Parameters to be Monitored</b>	<b>Standards/ Measurement/ Frequency</b>	<b>Institutional Responsibility</b>	<b>Implementation Schedule</b>
Interference with other infrastructure facilities	Public inconvenience due to accidental damage / disturbance to utility infrastructure.	Measures shall be taken to minimise accidental damage / disturbance to utility infrastructure facilities such as electricity lines, water pipe lines, telecom lines, sewage lines etc. Measures include prior consultation with relevant utility authorities, obtaining approvals, data and maps and follow their instructions. Use of well trained and experienced machinery operators to reduce accidental damage to the public utilities and arrangement with the utilities to notify and restore services immediately if damage / disturbance occurs. This includes payment of fees / costs for any repair work.	Accidental damages caused to utility infrastructure/ Disruption to commercial and public activities/public complaints	Utility guidelines, public complaints Site inspections – As required	Contractor subject to monitoring by WBSEDCL / PMA. Payment of fees / costs for any repairs for accidental damages shall be Contractor's responsibility.	Construction Phase
Road and railway crossings	Public inconvenience due to accidental damage / disturbance to road and railway infrastructure.	Follow instructions / guidelines issues by the road and railway authorities and conditions of approvals / permits. Use HDD method for laying of underground cables as per technical specifications. Use of well trained and experienced machinery operators to reduce accidental damage. Maintain required clearances as per guidelines. Notify road and railway authorities immediately if any accidental damage occurs and pay applicable fees / costs for carrying out necessary repairs.	Accidental damages to road and railway infrastructure	Guidelines issued by road and railway authorities. Visual inspections - Once	Contractor subject to monitoring by WBSEDCL / PMA  Payment of fees / costs for any repairs for accidental damages shall be Contractors responsibility.	Construction Phase
<b>B Environment Resources</b>						



<b>Project Activity</b>	<b>Potential Environmental Impact</b>	<b>Mitigation Action</b>	<b>Parameters to be Monitored</b>	<b>Standards/ Measurement/ Frequency</b>	<b>Institutional Responsibility</b>	<b>Implementation Schedule</b>
AB Cable replacements for existing lines passing through environmentally sensitive areas	Impact to the existing environment	Lines passing through environmentally sensitive areas such as forest areas, protected areas, heritage sites etc shall be identified based on network survey. Necessary permits / approvals shall be obtained from concerned authorities to carry out proposed work. Work shall be carried out strictly in accordance with the conditions / parameters of the permits issued by the relevant authorities.	Construction work in environmentally sensitive areas	Conditions of permits / approvals and clearances Site Inspections – As required	Contractor subject to monitoring by WBSEDCL / PMA	Construction Phase
Line construction work	Noise and vibrations	Selection of construction techniques and machinery to minimize noise and vibrations. Associated construction works in residential areas shall be limited to daytime only.	Noise pollution during construction. Public Complaints	GoI and IFC Noise control regulations Site Inspections - Quarterly	Contractor subject to monitoring by WBSEDCL / PMA	Construction phase
Provision of facilities for construction workers	Contamination of receptors (land, water, air)	Construction workforce facilities to include proper sanitation (soak pits/septic tanks), water supply and waste disposal facilities. Workforce is not allowed to harvest wood, therefore the Contractor to ensure LPG gas cylinders are provided to labor camps.	Amenities for Workforce.	Presence of proper sanitation, water supply and waste disposal facilities - Visual inspection (Continuous)	Contractor subject to monitoring by WBSEDCL / PMA	Construction phase
Pole and distribution transformer erection, underground cabling and substation control room extensions	Noise and vibrations	Selection of construction techniques and machinery to minimize noise and vibrations. Associated construction works shall be limited to daytime only.	Noise pollution during construction. Public Complaints	GoI and IFC Noise control regulations - Quarterly	Contractor subject to monitoring by WBSEDCL / PMA	Construction phase

<b>Project Activity</b>	<b>Potential Environmental Impact</b>	<b>Mitigation Action</b>	<b>Parameters to be Monitored</b>	<b>Standards/ Measurement/ Frequency</b>	<b>Institutional Responsibility</b>	<b>Implementation Schedule</b>
Underground cabling and substation control room extensions	Impairment of ambient air quality	Spraying of water to dust-generating areas; Covering excavated soil/dump during off-work with tarpaulin; Provide temporary enclosure of dust-generating construction area/activities; Trucks transporting construction materials that generate dust will be covered;	Construction techniques and dust control measures	GoI and IFC Air Quality regulations - Quarterly	Contractor subject to monitoring by WBSEDCL / PMA	Construction phase
Substation control room extensions and distribution transformer erections	Hazardous waste	Ensure transformer oil supplied is PCB free as per technical specifications. Ensure safe handling and disposal of hazardous waste including transformer oil and asbestos in accordance with applicable regulations and procedures.	Hazardous waste disposal	Hazardous Waste (Management and Handling Rules,) 1989 - Continuous	Contractor subject to monitoring by WBSEDCL / PMA	Construction phase
Impact on construction waste, Health and safety	Pollution risk and generation of construction wastes	<p>Implement agreed PPP and follow General EHS Guidelines for the use and storage of fuel, oil, and chemical including prevention and control of hazards associated with spill prevention, emergency response, clean up and contaminated soil remediation.</p> <p>Fuel, oil and chemicals used to be kept under lock and key and stored in labelled, sealed containers on drip trays to provide secondary containment, ideally, they will be located on an impermeable surface and be under cover</p> <p>Mounting of plant containing oil and diesel on drip trays to catch leaks.</p> <p>Refuelling operations, equipment servicing and wash down to take place</p>	Works in accordance with EMP measures and approved PPP and CWMP	Compliance with national laws and regulations - Continuous	Contractor subject to monitoring by WBSEDCL / PMA	Construction phase

Project Activity	Potential Environmental Impact	Mitigation Action	Parameters to be Monitored	Standards/ Measurement/ Frequency	Institutional Responsibility	Implementation Schedule
		<p>on an impermeable surface at least 25m from watercourses, and 50m from springs and wells, with drainage directed through oil and grease interceptors before being discharged into a settling pond prior to discharge offsite</p> <p>Provide sufficient absorbent materials (e.g. sorbents, dry sand, sandbags) on-site for soaking up fuel, oil or chemical leaks/spills</p> <p>Provision of an appropriate domestic solid waste and construction waste collection and disposal system.</p> <p>Collect and segregate construction wastes including scrap metal, oils, and solid waste.</p> <p>Store all wastes in designated, labelled area in an environmentally sound manner e.g. oils to be stored in sealed drums on drip trays, solid wastes to be stored in an enclosed bin.</p> <p>Recover recyclable wastes that could be reused or sold to recyclers. Prohibit burning of construction wastes.</p> <p>Prohibit dumping of construction wastes into canals, rivers, agricultural fields etc.</p> <p>Scrap metal waste to be immediately removed off-site to the DISCOM stores</p>				

Project Activity	Potential Environmental Impact	Mitigation Action	Parameters to be Monitored	Standards/ Measurement/ Frequency	Institutional Responsibility	Implementation Schedule
		for appropriate reuse or disposal with all waste transfer records retained.				
<b>C Ecological Resources</b>						
Trimming /cutting of trees	Loss of vegetation and deforestation	Trees / bushes that can survive cutting shall only be pruned. Line routes shall be planned or re-routed so that no plant species of conservation status are cut. If necessary line Construction works will not be scheduled following harvest time to minimize damage to cash crops, Contractor is permitted to clear vegetation subject to consultation with crops owners.  Felled trees and other cleared or pruned vegetation shall be disposed in accordance with applicable procedures.	Species of conservation status retained as approved by statutory authorities.  Disposal of cleared vegetation as approved by the statutory authorities	Presence of target species in Right of Way (RoW) following vegetation clearance. Site Inspections – Twice during pre-construction and upon completion	Contractor subject to monitoring by WBSEDCL / PMA	Construction phase
Conduct of construction workers	Loss of vegetation and deforestation	Construction workers prohibited from harvesting wood in the project area during their employment. Contractor to provide LPG gas cylinder / cooker for labour camps.	Illegal wood/vegetation harvesting - number of incidents reported	Complaints by local people or other evidence of illegal harvesting – Once	Contractor subject to monitoring by WBSEDCL / PMA	Construction phase
	Effect on fauna	Prevent work force from disturbing the flora, fauna including hunting of domestic animals, wildlife and fishing in water bodies.  Awareness programme for workers regarding conservation of flora, fauna including ground vegetation to all workers.	Habitat loss	Complaints by local people or other evidence of illegal hunting / fishing - Once	Contractor subject to monitoring by WBSEDCL / PMA	Construction phase

<b>Project Activity</b>	<b>Potential Environmental Impact</b>	<b>Mitigation Action</b>	<b>Parameters to be Monitored</b>	<b>Standards/ Measurement/ Frequency</b>	<b>Institutional Responsibility</b>	<b>Implementation Schedule</b>
Site clearance for underground cabling and substation control room extensions	Loss of vegetation	Marking of vegetation to be removed prior to clearance, and strict control on clearance area as per approved site area requirements. .	Vegetation marking and clearance control (area in m <sup>2</sup> )	Clearance strictly limited to target vegetation-Once	Contractor subject to monitoring by WBSEDCL / PMA	Construction phase
<b>D Human Environment</b>						
All construction works interfering with public areas and facilities	Nuisance to the general public	Notify general public in the locality of the proposed construction activity, scheduled commencement and completion period and contact details for information and complaints. Safe access to property and roads should be maintained and alternative routes and access provided where there are temporary diversions or blockages	Notifications	Site inspections - Once	Contractor subject to monitoring by WBSEDCL / PMA	Construction phase
Electricity supply interruptions for line construction works	Inconvenience to electricity consumers and negative impacts on social, agricultural and commercial activities.	Pre-plan line construction works so that supply interruption durations required for AB cable replacements are minimized. Follow stipulated WBSEDCL procedure for obtaining shutdown approval to carry out work on existing feeders. Make arrangements to inform affected consumers in advance. Make arrangements for immediate restoration of supply upon completion.	Supply interruption hours for construction activity	DISCOM procedure for providing shutdown approval.  Supply Interruption hours - As Required	Contractor and WBSEDCL	Construction phase

Project Activity	Potential Environmental Impact	Mitigation Action	Parameters to be Monitored	Standards/ Measurement/ Frequency	Institutional Responsibility	Implementation Schedule
Power line and distribution transformer construction, underground cabling and substation control room extensions	Possible safety risks to general public and construction workers	<p>Implement safety measures to minimize safety risks to general public and workers as per approved Safety Plan</p> <p><b>Safety of general public</b> : measures shall include demarcation of high risk construction activity areas such as pole pits and trenches, display warning signs / beacons / notices, traffic rearrangements / diversions, conduct safety audits and other measures as per approved safety plan. Ensure necessary safety clearances to houses / buildings are maintained.</p> <p><b>Safety of workers:</b> measures shall include provision of PPE for all workers, use of proper equipment, documentation and training on safe working practices, regular safety audits, work permit process, temporary earthing, temporary stays for line stringing, follow sag tension charts for stringing of lines, establish occupational health and safety management system as per Contract provisions, employment of a safety officer and other measures as per approved safety plan and technical specifications.</p>	Violations of safety regulations, accidents, safety audit reports, public complaints	Approved Safety Plan, Technical Specifications, CEA safety regulations - Continuous	Contractor / safety officer subject to monitoring by WBSEDCL / PMA	Construction Phase
Construction of power lines and facilities at or vicinity of heritage sites	Disturbance to activities at heritage sites / Loss of aesthetic value	Schedule and carry out construction work in consultation with heritage site authorities to minimize disturbances to regular activities at site. Comply with the conditions and parameters of permits / approvals provided.	Work Schedules and implementation activity	Requirements as per permits / approvals / detailed designs - Once	Contractor subject to monitoring by WBSEDCL / PMA	Construction Phase

<b>Project Activity</b>	<b>Potential Environmental Impact</b>	<b>Mitigation Action</b>	<b>Parameters to be Monitored</b>	<b>Standards/ Measurement/ Frequency</b>	<b>Institutional Responsibility</b>	<b>Implementation Schedule</b>
Temporary use of land	Disturbance / Losses to neighbouring land uses/ values	<p>Access to sites for workers and machinery shall be through roads / public land. If access through private land required in exceptional cases prior permission from land owners shall be obtained.</p> <p>No damage shall be done to public / private properties during temporary use. If private lands are used for temporary storage of materials, labour camps, pre-construction works etc. it should be done in agreement with the land owners and upon payment of rentals as required. Material / debris shall not be stored along roads, near water bodies or in public lands in a manner that disturb intended usage of such facilities. Temporarily used land shall be reinstated to original condition following completion of construction works</p>	Site arrangements	Site Inspections - Once.	Contractor subject to monitoring by WBSEDCL / PMA	Construction Phase
Chance find of cultural resources and property/archaeological features	Loss/theft of precious archaeological item uncovered during excavation	In case of chance find of physical cultural resources and property/archaeological features damage to such property shall be prevented, concerned authorities shall be notified and ensure safety of such property until handover to concerned authorities.	Chance find information	GoI's Treasure and Trove Act. – As required	Contractor subject to monitoring by WBSEDCL / PMA	Construction Phase
Transportation and storage of materials	Nuisance to the general public	<p>Transport loading and unloading of construction materials should not cause nuisance to the people by way of noise, vibration and dust.</p> <p>Avoid storage of construction materials beside the road, around water bodies, residential or public sensitive locations.</p> <p>Construction materials should be stored</p>	Site arrangements	Site Inspections - Quarterly	Contractor subject to monitoring by WBSEDCL / PMA	Construction Phase

Project Activity	Potential Environmental Impact	Mitigation Action	Parameters to be Monitored	Standards/ Measurement/ Frequency	Institutional Responsibility	Implementation Schedule
		in covered areas to ensure protection from dust, emissions and such materials should be bundled in environment friendly and nuisance free manner.				
Soil erosion during auguring/ excavation of pole foundation.		<p>Minimize removal of existing vegetation and topsoil to that which is absolutely necessary.</p> <p>Infertile and rocky material will where possible be reused as fill material, if it needs to be taken off site it will be disposed by licensed waste management operator at designated disposal area suitable for accepting inert wastes.</p> <p>Excavation will be limited to within the agreed corridor of impact, ideally road reserve. (no resettlements permitted for this project)</p> <p>Use of auguring to limit the area to be disturbed for installation pole foundation. Undertake installation of poles during the dry season to minimize exposed areas subject to erosion by surface water runoff.</p>	<p>Works in accordance with EMP measures and approved CEMP provisions</p> <p>Compliance with national laws and regulations</p>	Site Inspections - Quarterly	Contractor subject to monitoring by WBSEDCL / PMA	Construction Phase
Occupational health and safety	Impact of Workers Health & Safety	Require workers to confirm they have seen and understood the requirements of the Occupational Health and Safety (OHS) plan before proceeding with the work.	Works in accordance with EMP measures and approved H&S Plans	Compliance with national laws and regulations - Once	Contractor subject to monitoring by WBSEDCL / PMA	Construction Phase
Community health and safety such as toppling of concrete poles,	Impact on Community Health & Safety	Install visual and written warning signage's to the public to include the ISO 7010 Hazard Type: Electrical Symbol warning of the risk of electrocution.	Works in accordance with EMP measures and H&S Plans	Compliance with national laws and regulations - Continuous	Contractor subject to monitoring by WBSEDCL / PMA	Construction Phase



Project Activity	Potential Environmental Impact	Mitigation Action	Parameters to be Monitored	Standards/ Measurement/ Frequency	Institutional Responsibility	Implementation Schedule
<p>traffic and accidents, emergency spill of materials, and access of villagers to dangerous working areas.</p>		<p>Provision for ensuring security of the cable to avoid vandalism. For pole mounted transformers a suitable anti-climbing deterrent, to be used together with suitable warning signs.</p> <p>Fence and sign immediate working area to prevent public access during construction works.</p> <p>Do not leave hazardous conditions (e.g. unlit open excavations without means of escape) overnight unless no access by public can be ensured</p> <p>Prevent standing water as it may become a breeding habitat for mosquitoes etc.</p> <p>During construction works provide signage detailing site and office contacts in case of grievance.</p> <p>Before handover all poles to be confirmed to have adequate foundation that they will remain vertical during operation, and that all the feeder lines are correctly tensioned.</p> <p>Wherever possible, the contractor should not discriminate and should proactively encourage the employment of suitably skilled women on the project.</p>				
Capacity Building	Impacts to consumers due to construction	Provision of information and training (if required) on the requirements regarding construction of works.	Equipment O&M manuals, Specifications and training (if	Documentation and Training provided – Once	Training arrangement by Contractor	Construction Phase

Project Activity	Potential Environmental Impact	Mitigation Action	Parameters to be Monitored	Standards/ Measurement/ Frequency	Institutional Responsibility	Implementation Schedule
	procedures.		applicable)		subject to monitoring by WBSEDCL / PMA	

**POST CONSTRUCTION PHASE**

**After completion of all activities, the entire installations will be handed over to the Distribution (O&M) wing for commercial operations. The Distribution (O&M) wing has its own set up and some other corporate set up to look after the all the issues related with environment and operation and maintenance during the declared defect liability period.**

**Bidder is responsible for designing appropriately to facilitate their implementation as per technical parameters specified in the bidding documents. But Bidder has the role of rectification of commissioned project if any defect is intimated by the Distribution (O&M) wing, within the defect liability period.**



## APPENDIX 1: SAFEGUARDS SCREENING FORMS

One consolidated set of screening forms is to be completed for each subproject, reflecting all components/activities included under it. The consolidated forms are to be submitted to ADB for clearance prior to the commencement of any construction works associated with the components/activities covered by them. Since some subprojects may be implemented by WBSEDCL/contractors on a rolling basis not all components/activities may be confirmed upfront. In the case additional subproject components/activities are identified following initial submission, the consolidated forms can be updated and resubmitted to ADB for clearance.

Part A. General information – provide for all subprojects.

Part B. Project description

- Conversion to ABC subprojects, complete Form 1
- Feeder segregation and bifurcation subprojects, complete Form 2

Part C. Baseline

- Conversion to ABC following existing alignment with no diversion, complete bold items of form only
- Conversion to ABC with minor diversion, complete one form for each component/activity
- 11 kV feeder segregation and bifurcation complete one form for each component/activity

Part D. Screening checklists

- Environment – one checklist per subproject
- Involuntary resettlement – one checklist per subproject
- Indigenous peoples – one checklist per subproject

Provide requested maps and photographs as separate files using clear naming protocol to identify them.

### A. GENERAL INFORMATION

Subproject Name:     —

Contract Package:    —

Contractor: \_\_\_\_\_

Construction timeline:  —

- Spreadsheet of all components/activities included in the subproject to be attached.
- For ABC conversions list by division and district the names of the villages included with latitude/longitude grid coordinates for each, flagging any that will involve a minor diversion.
- For feeder separation list by division and district the feeder name together with the substation and names of villages connected to it with latitude/longitude grid coordinates for each.

### B. PROJECT DESCRIPTION

**Form 1.** If the subproject involves conversion to ABC complete this checklist on a division wise basis, reflecting all components/activities included under that division.

Items	Details
<b>Division wise description:</b>	
Length of LTOH Bare Conductor to be replaced with ABC	Ckm:
Map of line alignments (map to be provided for each village/ location)	Provide as a separate file a map for each village/location showing the line alignment,including details of any minor diversion,at a readable scale.
Confirm all ABC works within village boundaries	yes/no
Existing 11kV/400 V transformers utilised (details to be provided for all transformers used, photo(s) of transformers provided as a separate file)	Type: ground mounted/pole mounted Model and date of manufacture: Date of last oil change or maintenance, if known: Evidence of oil leak: none/minor/major Existing safety features: fence/warning sign/climb deterrent Pollution prevention features for ground mounted transformers: none/concrete platform/bund Photo of the transformer (if available)
New poles on existing alignments	Number of poles:
New poles on diverted routes, required in order to meet conductor clearances (maps to show details of any diversions)	Number of poles:
Construction camp location/size, if any (may be used for multiple components)	
Temporary workers camp location/size, if any (may be used for multiple components)	

**Form 2.** If the subproject involves 11 kV segregation & bifurcation complete this checklist for each component/activity included in the subproject.

Items	Details
<b>Subproject component description:</b>	
Length of 11kV feeder line required	Ckm above ground line: <ul style="list-style-type: none"> <li>• Bare Conductor :</li> <li>• HT ABC :</li> </ul> Ckm underground line: Number of railway crossings: Number of SH/NH crossings Number of River crossings :
Map of feeder line route (map(s) to be provided for entire route)	Insert or provide as a separate file map showing the line alignment at readable scale
Existing substation connection (details provided for all substations; photo(s) of substations provided as a separate file)	Name: New feeder required: no/control panel/outdoor cabling and circuit breaker Photo of the substation (if available)
Existing 11kV/400 V transformer used (details provided for all transformers; photo(s) of transformers provided as a separate file)	Type: ground mounted/pole mounted Model and date of manufacture: Date of last oil change or maintenance, if known: Evidence of oil leak: none/minor/major Existing safety features: fence/warning sign/climb deterrent Pollution prevention features for ground mounted transformers: none/concrete platform/bund Photo of the transformer (if available)
New 11kV/440 V transformer (details to be provided for all transformers)	New transformer required: yes/no Type: ground mounted/pole mounted
Construction camp location/size, if any (may be used for multiple components)	
Temporary workers camp location/size, if any (may be used for multiple components)	

### C. BASELINE

For each minor diversion related to conversion to ABC and 11 kV feeder segregation—and bifurcation component/activity included in the subproject complete all questions in the following form.

For conversion to ABC following existing alignment with no diversion, complete only the questions in **bold**.

<b>Land Use and Sensitive Receptors</b>	<b>Details</b>
Existing road reserve inside habitation	km of line:
Existing road reserve outside habitation	km of line:
Existing field boundaries	km of line:
Agricultural land traversed	km of line: number of poles:
Community or private forest land traversed	km of line: number of poles: tree cutting required: yes/no
Other land type traversed: (detail land types)	km of line:
Crossing of waterbodies e.g. rivers, streams, canals, drains, ponds etc.	Number of waterbody crossings: Insert or provide as a separate file a clear photo of each waterbody to cross
Presence of critically endangered or endangered flora and fauna in the district, confirmed by forest officials etc.	yes/no
<b>Presence of</b> legally protected areas, other nationally or internationally recognized important ecosystems, natural or critical habitat, <b>including the following:</b> <ul style="list-style-type: none"> <li>• <b>legally protected areas such as National Parks, Wildlife Sanctuaries, ecosensitive zones etc.</b><sup>27</sup></li> <li>• <b>natural World Heritage Sites,</b></li> <li>• <b>Ramsar sites,</b></li> <li>• <b>important bird areas,</b></li> <li>• <b>key biodiversity areas,</b></li> </ul>	List any within 1 km, together with minimum distance to linealignment <sup>30</sup>

<sup>27</sup> This does not apply to the purchase and use of bonded asbestos cement sheeting where the asbestos content is less than 20%.

<sup>30</sup> IBAT to be run for a wider study area of 10km around village latitude/longitude grid coordinates using its multiple sites function to identify the presence of legally protected areas, important bird areas etc. IBAT report to be attached to confirm search undertaken.

<ul style="list-style-type: none"> <li>• elephant or tiger reserves,<sup>28</sup></li> <li>• defined elephant and tiger corridors,<sup>29</sup></li> <li>• reserve/protected forest areas,</li> <li>• biodiversity heritage sites,</li> <li>• wetlands etc.</li> </ul>	
<b>Internationally and nationally important physical cultural resources</b>	List any Cultural World Heritage Sites and ASI monuments including buffer zones within 1 km, together with the minimum distance to line alignment
Locally important physical cultural resources in the line alignment e.g. shrines, trees etc.	yes/no  If yes, provide details of these physical cultural resources including photos as separate files
Private/public trees located within the safety clearance and requiring to be cut	Number:  Confirm species cut do not include CR, EN, endemic, restricted range species: yes/no
<b>School compounds and/or buildings located within the safety clearances</b>	yes/no  If yes, provide photos clearly showing baseline situation (attach as separate files) with a map clearly showing details of the line alignment, and how safety clearances will be achieved by project
School compounds and/or buildings situated within 5m of the line alignment	yes/no  If yes, provide photos clearly showing baseline situation (attach as separate files) with maps clearly showing details of the line alignment, and how safety clearances will be achieved by project
Other public/private buildings that are situated within 5m of the line alignment	yes/no  If yes, provide photos clearly showing baseline situation (attach as separate files) with maps clearly showing details of the line alignment, and how safety clearances will be achieved by project

<sup>28</sup> This does not apply to the purchase and use of bonded asbestos cement sheeting where the asbestos content is less than 20%.

<sup>29</sup> Details of defined elephant corridors available from [https://wti.org.in/project\\_docs/WTI\\_101\\_corridors\\_map.jpg](https://wti.org.in/project_docs/WTI_101_corridors_map.jpg) with details of defined tiger corridors available from [https://www.conservationindia.org/wp-content/files\\_mf/Tiger-corridors-2.pdf](https://www.conservationindia.org/wp-content/files_mf/Tiger-corridors-2.pdf)



For each 11 kV feeder segregation & bifurcation component/activity involving an existing substation complete the following form, provide the requested maps and photographs as separate files using clear naming protocol to identify them.

<b>Substation Name:</b>					
<b>Year of establishment:</b>					
<b>Grid Reference:</b>					
<b>Aerial map of substation, if available</b>					
<b>Photo of substation compound:</b>					
<b>Photo of control building and details of wall/roof materials:</b>					
<b>No. transformers and dates of manufacture with photo of rating plate:</b>					
<b>Area of substation and layout map:</b>					
<b>Nearest residence and habitation (name and distance in m):</b>					
<b>Total staff at substation (technical and non-technical):</b>					
<b>Audit Checks:</b>	<b>Yes</b>	<b>No</b>	<b>Don't Know</b>	<b>N/A</b>	<b>Remarks, including the need for short-term or long-term corrective actions from the project-level EMP (attach photos to support findings)</b>
<i>Housekeeping / Waste Management</i>					
<i>Corrective action: short term/long term/none</i>					
Is the substation kept neat and tidy?					
Are there any trip hazards on the ground e.g. open channels, materials, equipment, trash laying around?					
Is there any general waste storage and/or disposal on-site?					Provide details of general waste storage and how it is disposed of:
Is there any waste burning on site?					
Are there any hazardous wastes (solid/liquid/gas) being stored and/or disposed of?					How are any hazardous wastes (solid/liquid/gas) being stored and disposed of?
Is end of life or unused equipment being stored on site?					
Is there a dedicated, labelled storage area for this equipment?					
Are fuel, oil or chemicals being stored on site?					
Are there empty drums or old transformers on site?					

Is there a dedicated, labelled storage area for fuel, oil, and chemicals, empty drums, and/or old transformers?					
Does the storage area have an impermeable floor?					
Is the storage area uncovered?					
Is the storage area locked?					
Does the storage area have a spill containment bund of 110% capacity?					
Are material data sheets for the fuels, oil or chemicals displayed?					Provide copies transformer oil material data sheets:
Has there been any pest problem on site?					
Are any pest control measures undertaken on site?					Provide details of control measures and how often undertaken:
<i>Transformer Oil Leakage</i>					
<i>Corrective action: short term/long term/none</i>					
Do the transformers have a label indicating it contains PCB or is PCB free?					
Is any other evidence available to confirm transformers are PCB free?					Provide copies of any documentary evidence:
Is it known when the transformer oil was last changed?					Confirm date:
Is a maintenance logbook kept on the premises?					Describe schedule of maintenance:
Are the transformers mounted on an impermeable platform?					
Does the transformer platform have a spill containment bund/sump of 110% capacity?					
Is there any evidence of oil leaking or having					

previously leaked from transformers					
Is there any spill equipment available on site (e.g. sand, cloths, or other absorbent materials)?					
<i>Lighting and Ventilation</i>					
<i>Corrective action: short term/long term/none</i>					
Is adequate ventilation provided in control building?					
Are all vents free of blockages?					
Is heating and/or air con available?					
Is adequate natural or artificial lighting provided in control building?					
Is adequate lighting provided in the substation compound at night?					
Are all lights in working order?					
<i>First Aid Equipment</i>					
<i>Corrective action: short term/long term/none</i>					
Is a first aid kit available on site?					Elaborate on contents:
Is it clearly labelled where the first aid kit is stored?					
Is the first aid equipment within its expiry date?					
Do any staff on site have first aid training?					Confirm how many and the extent of training received:
Is one staff with first aid training present on site at all times?					
Are there any posters showing first aid procedures especially for electrocution?					
<i>Fire Safety Equipment</i>					
<i>Corrective action: short term/long term/none</i>					
Does the control building have fire detectors and alarm?					
Is the alarm system operational?					
Is fire fighting equipment present?					Elaborate on equipment provided, No. fire extinguishers

					No. of fire buckets filled with sand
Do fire extinguishers have an in-date service record?					
Is a record of fire alarm testing and fire drills available on site?					
Do any staff on site have fire training?					
Are there any notices or posters describing procedures to be followed in the event of a fire?					
<i>Community Health and Safety</i>					
<i>Corrective action: short term/long term/none</i>					
Is there a security fence and gates?					
Does the security fence have any gaps permitting entry?					
Are the gates kept locked?					
Is 24/7 security guard present?					
Is the door to the control room kept locked?					
Are there written or graphic "danger of electrocution" signs posted on the fence/gates?					
Are there written or graphic "danger of electrocution" signs posted on electrical equipment?					
Can any noise from transformer hum be heard?					
Is shielding equipment/materials installed to decrease electromagnetic field exposure?					
<i>Handling Emergencies</i>					
<i>Corrective action: short term/long term/none</i>					
Is an emergency plan available?					Provide copies of any documentary evidence:
Are emergency exits signed and clear of blockages?					

Is the location and phone number of doctor and hospital posted in a clear location?					Distance to nearest doctor / clinic: Distance to nearest hospital able to treat electrocution accidents and other serious conditions:
Is there an emergency eye wash or shower?					
Is an accident book available on site?					Elaborate on incidents recorded:
<i>Health and Safety of Staff</i>					
<i>Corrective action: short term/long term/none</i>					
Does the control building look to be structurally sound?					
Is there any evidence of asbestos on site?					
Did auditor receive an OHS site induction?					
Have staff on site received OHS training?					Clarify division of labour between on-site workers and other in-coming specialised DISCOM maintenance workers:
Are staff on site wearing PPE?					
Is there a store of PPE available on site?					
Do staff avail of personal exposure monitoring equipment to warn of exceeding exposure levels to electromagnetic fields?					
<i>Drainage</i>					
<i>Corrective action: short term/long term/none</i>					
Is there any standing water visible on site?					
Is a drainage system provided?					
<i>Sanitation and Welfare Facilities</i>					
<i>Corrective action: short term/long term/none</i>					
Is a toilet available on site?					Are there facilities for male and female?
Is the toilet inside staff building or outside it?					
Does the toilet connect to septic tank with soakaway or sewerage system?					
Are handwashing facilities available?					
Is hot and cold water available?					
Is soap provided?					

Does the toilet have lock or vacant indicator?					
Is potable water available on site?					Elaborate on the source:
Is there any evidence of potable water meeting Drinking Water Standards?					Provide copies of any documentary evidence:
Are staff stationed at substation during on shift hours and how many, including security guards?					If so, how many? How long are staffs' shifts? How long are security guards' shifts?
Is a food preparation and clean eating area available?					Is the area free from any contamination from work processes?
Is cooking fuel used at site?					Describe fuel(s) used:
Are staff staying at the substation overnight (out of hours) and how many?					
Is there dedicated workers accommodation and/or shelters?					Describe worker accommodation and facilities provided including for security guards e.g. does it protect from rain and sun; does it have a bed; heating; air conditioning etc.

## D. SCREENING CHECKLISTS

### D-1. Screening of Subprojects for Environment

One environmental screening checklist is to be completed for each subproject, informed by the project description and baseline forms completed in respect of all components/activities included under it.

Potential environmental impacts for both conversion to ABC and feeder lines have already been identified at the Project level and mitigation for these impacts has been identified in the project-level EMP so only locations issues need further consideration. If the answer to any of the screening questions below is a yes or not known, then as part of updating the IEE a site-specific assessment might be required for any components/activities of concern to determine the significance of potential impacts and any site-specific mitigation measures required.

Subprojects may only be categorized C for environment without further consultation with the ADB environment safeguards specialist if the response to all screening questions is no.

Subproject Specific Screening	Yes	No	Not Known	Remarks
<b>A. Subproject Siting</b> Does any subproject component/activity extend beyond boundaries of one village?				

Does any subproject component/activity extend beyond the built-up area of existing habitations?				
Is any subproject component/activity adjacent to or within 1 km of any of the following or any other legally protected areas, other nationally or internationally recognized important ecosystems, natural or critical habitat? Informed by Environment Baseline Form/IBAT Check				
• National Park				
• Wildlife Sanctuary				
• Eco Sensitive Area				
• World Heritage Site (natural or cultural)				
• ASI monument				
• Other National Protected Area (state type)				
• Buffer Zone of Protected Area (state which)				
• Ramsar Site				
• Important Bird Area				
• Key Biodiversity Area				
• Elephant Reserve				
• Tiger Reserve				
• Defined elephant corridor				
• Defined tiger corridor				
• Reserve/protected forest area				
• Biodiversity heritage site				
• Other forest area (not protected)				
• Wetland				
<b>B. Potential Environmental Impacts</b> Will any of the subproject components/activities...				
• involve the construction of a new line i.e. 11 kV segregation and bifurcation?				
• result in the conversion or degradation of natural habitat?				
• encroach on any legally protected areas, other nationally or internationally recognized important ecosystems, natural or critical habitat per Section A?				
• encroach on any buffer zones or connecting corridors of legally protected areas, other nationally or internationally recognized important ecosystems, natural or critical habitat per Section A?				

• encroach on community or private forest?				
• result in damage to physical cultural resources or require their removal?				
• encroach on any historical/cultural areas per Section A?				
• encroach on or within the safety clearances for school compounds or buildings?				
<b>C. Subproject Components/Activities</b> Will any of the subproject components/activities cause additional site-specific impacts to those detailed in the IEE and covered by the project-level EMP...				
• <i>Component A [insert details]</i>				
• <i>Component B [insert details]</i>				
• <i>Component C [insert details]</i>				
• ....				



## D-2 Screening of Subprojects for Involuntary Resettlement

One involuntary resettlement screening checklist is to be completed for each subproject, informed by the project description and baseline forms completed in respect of all components/activities included under it.

Probable Involuntary Resettlement Effects	Yes	No	Not Known	Remarks
<b>Involuntary Resettlement Impacts</b>				
1. Does the subproject component have any impact on private land (i.e. installation of poles on and lines over the land)?				If no, then C as only government or public land affected, and the record of land ownership should be collected and kept. If yes, then B as there is impacts on private land, then social due diligence required as per Appendix 7.
2. If there is an impact on private land. Was alternative route by utilizing within an existing public Right of Way (ROW) explored?				
3. Is the site for the impact known?				
4. Is the ownership status and current usage of land to be acquired known?				
5. Will there be loss of shelter and residential land due to land acquisition?				
6. Will there be loss of agricultural and other productive assets due to land acquisition?				
7. Will there be losses of crops, trees, and fixed assets due to land acquisition?				
8. Will there be loss of businesses or enterprises due to land acquisition?				
9. Will there be loss of income sources and means of livelihoods due to land acquisition?				
<b>Involuntary restrictions on land use or on access to legally designated parks and protected areas</b>				
10. Will people lose access to natural resources, communal facilities and services?				
11. If land use is changed, will it have an adverse impact on social and economic activities?				
12. Will access to land and resources owned communally or by the state be restricted?				

<b>Information on Displaced Persons:</b>
Any estimate of the likely number of persons that will be displaced by the Subproject? <input type="checkbox"/> No <input type="checkbox"/> Yes If yes, approximately how many?
Are any of them poor, female-heads of households, or vulnerable to poverty risks? <input type="checkbox"/> No <input type="checkbox"/> Yes
Are any displaced persons from indigenous or ethnic minority groups? <input type="checkbox"/> No <input type="checkbox"/> Yes

**D-3. Screening of Subprojects for Indigenous Peoples Resettlement as per ADB**

One indigenous people screening checklist is to be completed for each subproject, informed by the project description and baseline forms completed in respect of all components/activities included under it.

<b>KEY CONCERNS</b> (Please provide elaborations on the Remarks column)	<b>YES</b>	<b>NO</b>	<b>NOT KNOWN</b>	<b>Remarks</b>
<b>A. Indigenous Peoples Identification</b>				
1. Are there socio-cultural groups present in or use the subproject area who may be considered as scheduled tribes (hill tribes, schedules tribes, tribal peoples, and indigenous people or communities) in the subproject area?				
2. Are there national or local laws or policies as well as anthropological research/studies that consider these groups present in or using the subproject area as belonging scheduled tribes, tribal peoples, or cultural communities?				
3. Do such groups self-identify as being part of a distinct social and cultural group?				
4. Do such groups maintain collective attachments to distinct habitats or ancestral territories and/or to the natural resources in these habitats and territories?				
5. Do such groups maintain cultural, economic, social, and political institutions distinct from the dominant society and culture?				
6. Do such groups speak a distinct language or dialect?				
7. Has such groups been historically, socially and economically marginalized, disempowered, excluded, and/or discriminated against?				
8. Will the project target any of the groups and communities identified?				
9. Will the subproject directly or indirectly impact on their livelihood?				

**SUBPROJECTS MAY ONLY PROCEED IF 'NO' WAS SELECTED FOR ALL THE ABOVE INDIGENOUS PEOPLES SCREENING QUESTIONS.**

## APPENDIX 2: IEE UPDATE OUTLINE

Unless a site-specific assessment is required the consolidated screening forms, together with any consultation proformas, will comprise the basis for the IEE update for each subproject. The IEE update for each subproject will be attached to the IEE in the form of an annex.

If a site-specific assessment is required for any components/activities, then a detailed assessment of the potential impacts and risks is to be included in the update annex, together with a site-specific EMP to accompany the project-level EMP for implementation by the contractor.

- **Description of the Project**, attach project description section based on completed project description forms for the subproject.
- **Description of the Environment**, attach baseline section based on completed baseline forms for all subproject components/activities together with a short elaboration of the locational aspects of the baseline environment supported by the zone/division which the subproject covers with being attention paid to land use, population and vulnerabilities, presence of protected areas, KBAs, reserved forest areas, elephant and tiger corridors, physical cultural resources etc.
- **Existing Facilities Audit**, in relation to 11kV feeder lines attach completed environment audit form for all existing substations in subproject, identifying applicable corrective actions.
- **Site-Specific Environmental Impacts and Mitigation Measures**, required only when screening identifies a site-specific assessment is required due to the presence of any sensitive receptors.
- **Information Disclosure, Consultation, and Participation**, for all subproject components/activities provide summary per below table and attach copies of completed consultation proformas.

Consultation Activities	Yes	No	
Meaningful consultations with community were conducted before finalizing the alignment			Details of consultations undertaken, Table 1 and 2
Suggestions received in finalizing the alignment			Suggestions provided, Table 3
If suggestions received, are they incorporated into design			

- **Site-Specific EMP**, not required unless site-specific EMP is required based on site-specific assessment.

## APPENDIX 3: SOCIAL DUE DILIGENCE REPORT OUTLINE

### Due Diligence for Construction of Feeders (11kV Lines)

#	Particulars	Description/Details/Status
1	Length of feeders and numbers of poles	
2	Name of villages	
3	Name of circle/block	
4	Name of district	
5	Is it a tribal area? The answer must be in Y/N	
6	Type of area (road/agricultural/ plantation/residential /commercial and etc.) in the corridor?	
7	Ownership of land (private/Government)	
8	If private land, how many poles are erected and how much private land occupied by the poles?	
9	Land use pattern for the locations of pole erection.	
10	Have the owner(s) provided consent to support <sup>31</sup> on erecting the poles?	
11	If consent not given, then has compensation been provided to how many households and how much per each household?	
12	Is the feeder passing over houses or buildings?	
13	If yes, how many structures affected approximately?	
14	What type of the structures (residential/commercial/Others)?	
15	What are the impacts on the structures (i.e. number of structures affected, number of households affected and size of damages)?	
16	If damaged, has compensation been provided to how many households and how much per each household? Or damages repaired?	
17	Is the feeder passing over religious or cultural properties?	
18	What are the impacts on these properties (i.e. numbers of structures and size of damages)?	
19	If damaged, has it properly repaired or has compensation for repair been given to how many households and how much per household?	
20	Does the feeder require tree cutting?	
21	If yes, approximate number of trees to be cut	
22	Types and names of trees to be cut	
23	Has compensation been provided to how many households and how much per each household?	
24	Does the feeder require tree trimming?	
25	If yes, approximate number of trees to be trimmed	
26	Have the owner(s) agreed the tree trimming?	
27	If not, then has compensation been provided to how many households and how much per each household?	
28	Does the feeder have any impact on crops?	

<sup>31</sup> The format for consent to support is included in section C of Appendix 8.

29	If yes, how much of the crop area affected?	
30	What are the types of crops?	
31	Have the owner(s) agreed to bear the crop losses?	
32	If not, then has compensation been provided to how many households and how much per each household?	
33	Any other impacts? Please specify.	
34	Have consultations undertaken how many times and with how many participants (men and women)?	
35	Remarks	

**Submitted by:**

(Name of the TKC:  
Name and signature:  
Position:  
Date:

**Verified by :**

Name of the PMA:  
Name and signature:  
Position:  
Date:

**Reviewed by:**

Project Manager,  
.....RE Project  
Name and signature:  
Position:  
Date: